

Tmedia

**System Installation Guide for
TMP6400 and TMS1600**

9010-00162-2A, Issue 2.2

The information in this document is subject to change without notice. No part of this document may be reproduced or transmitted in any form or by any means, electronic or mechanical, for any purpose, without the express written permission of **TelcoBridges**. **TelcoBridges** may have patents or pending patent applications, trademarks, copyrights, or other intellectual property rights covering subject matter in this document. The furnishing of this document does not give you license to these patents, trademarks, copyrights, or other intellectual property except as expressly provided in any written license agreement from TelcoBridges.

The information provided in this document is intended as a guide only. For the latest detailed engineering specifications, please contact **TelcoBridges** Customer Support. **TelcoBridges** is committed to continually improving product designs; as a result, product specifications may be subject to change without notification.

© 2003-2009 **TelcoBridges**. All rights reserved.

TelcoBridges, Tmedia, TMP6400, TMG3200, TMS1600 Switch, TMP800, TMG800, Toolpack API, On a Blade, System-Blade, TB-1+1 Solution, TB-16-E1/T1/J1, TB640-DS3, TB640-E1/T1/J1, TB640-OC3/STM-1, TB-8-E1/T1/J1, TB-IVR Mezzanine, TB-Multi-Blade, TB-Multi-Blade Mezzanine, TB-N+1-15 Solution, TB-N+1-3 Solution, TB-StreamServer, TB-Video, TB-VoIP Mezzanine, TM-1000 Network Probe are trademarks of **TelcoBridges** Inc. All rights reserved 2007. All other trademarks are property of their owners. This information is subject to change without notice.

Document Title: Tmedia System Installation Guide for TMP6400 and TMS1600
Document Number: 9010-00162-1A, Issue 2.2, 2009-09-12//10:58

HEAD OFFICE

91 rue de la Barre, Suite 01
Boucherville, Quebec
J4B 2X6, Canada

T +1 450 655 8993

F +1 450 655 9511

info@telcobridges.com

support@telcobridges.com

Preface

About this Guide

This guide describes the installation and setup of the Tmedia TMP6400 and the TMS1600 telecom platforms, as well as their connections to the Tmedia control, voice, and IP networks.

Conventions

Terminology	Description
Tmedia Control Network	The network link between Tmedia units, the Toolpack application server and stream servers.
Tmedia Switch Network	The network link between the TMP6400s and the TMS1600s.
Tmedia System	This term includes the combination of Tmedia units and the Tmedia control network, the Toolpack application server and stream servers.
Tmedia Unit	A generic reference to either the TMP6400 or the TMS1600.

Contact Us

If you have comments about this guide or any other TelcoBridges technical documentation, please send an E-mail to support@telcobridges.com.

Table of Contents

Chapter 1	Introduction	1
	1.1 Installation Overview	2
	1.2 Installation Prerequisites	3
	1.3 Preventing Electrostatic Discharge Damage.....	3
	1.4 Recommended Reading	4
Chapter 2	Equipment Connections	5
	2.1 Package Contents.....	6
	2.1.1 TMP6400 Package Contents	6
	2.1.2 TMS1600 Package Contents	7
	2.2 Rack mounting the Tmedia Equipment	8
	2.2.1 Prerequisites	8
	2.2.2 Vertical Placement of Tmedia Equipment	8
	2.2.3 Mounting the Tmedia Hardware	9
	2.3 Connecting to the Tmedia Control Network	10
	2.3.1 Prerequisites	10
	2.3.2 Interconnections	11
	2.4 Connecting to the VoIP Network	12
	2.4.1 Prerequisites	12
	2.4.2 Interconnections	13
	2.4.3 Connecting to the Serial Port of the Tmedia Unit.....	14
	2.5 Connecting to the PSTN	16
	2.5.1 Prerequisites	16
	2.5.2 RJ48 Type Interface (T1/E1/J1)	17
	2.5.3 SCSI Interface (T1/E1/J1)	18
	2.5.4 Dual BNC Interface (DS3).....	20
	2.5.5 Optical Interface (OC3/STM-1).....	21
	2.6 Connecting the TMP6400s to the TMS1600	22
	2.6.1 Prerequisites	22
	2.6.2 Interconnections	22
	2.7 Interconnecting Two TMP6401s or TMP6402s	24
	2.8 Powering Up.....	25
	2.8.1 Prerequisites	25
	2.8.2 Connecting to AC Power.....	25
	2.8.3 Connecting to DC Power.....	27
	2.8.4 Verifying the LED Status Indications	30
Chapter 3	Initial System Configuration	31
	3.1 Configuring the Terminal Emulator Application	32
	3.2 Using the set_boot and print_boot Commands	33
	3.3 Creating a Shell Password	37
	3.4 Applying Changes	38
	3.5 Tmedia Default IP Addresses	38

Chapter 4	Toolpack Installation	39
4.1	ToolPack Operating System Platforms	40
4.2	Installation Guidelines	40
Chapter 5	System Upgrades.....	41
5.1	Installing a Firmware Package	42
5.2	Removing a Firmware Package	42
5.3	Installing a New License	43
Chapter 6	Troubleshooting Tools.....	45
6.1	Reporting a Problem	46
6.2	Setup Information.....	46
6.3	tblogtrace (Mandatory)	46
6.4	Tbdebug Dump Files (Mandatory).....	47
6.5	Backdoor Tools	47
6.5.1	tbx_cli_tools_remote	47
6.5.2	Line/Trunk Status (Tbshows).....	48
6.5.3	VoIP Traffic Capture.....	48
6.5.4	Wireshark (formerly called Ethereal).....	48
6.5.5	Tbstreamlisten.....	48
6.5.6	Stream Server Audio Packets to Wave File	49
6.5.7	tbsigtrace Signaling Traces	49
6.6	General Debugging Tips	50

Chapter 1 Introduction

This chapter provides an introduction to the installation and setup of a Tmedia system using the TMP6400 and the TMS1600.

The following topics are covered:

- Installation overview
- Installation prerequisites
- Other recommended reading

1.1 Installation Overview

The installation and setup of a Tmedia system involves the installation of one or more Tmedia units, such as the TMP6400, TMP6402, and the TMS1600, as shown in figure 1.1 on page 2. The interconnection between these units is described and procedures to guide you through the installation and setup of your Tmedia system are provided (by presenting you with a series of chapters dealing with installation tasks) in the following order:

- Rack mounting the Tmedia units
- Connecting TMP6400(s) to the TMS1600(s).
- Connecting to the Tmedia control network
- Connecting to the VoIP network
- Connecting to the PSTN
- Powering Up
- Installing Toolpack
- Initial System Configuration
- System Upgrades
- Troubleshooting

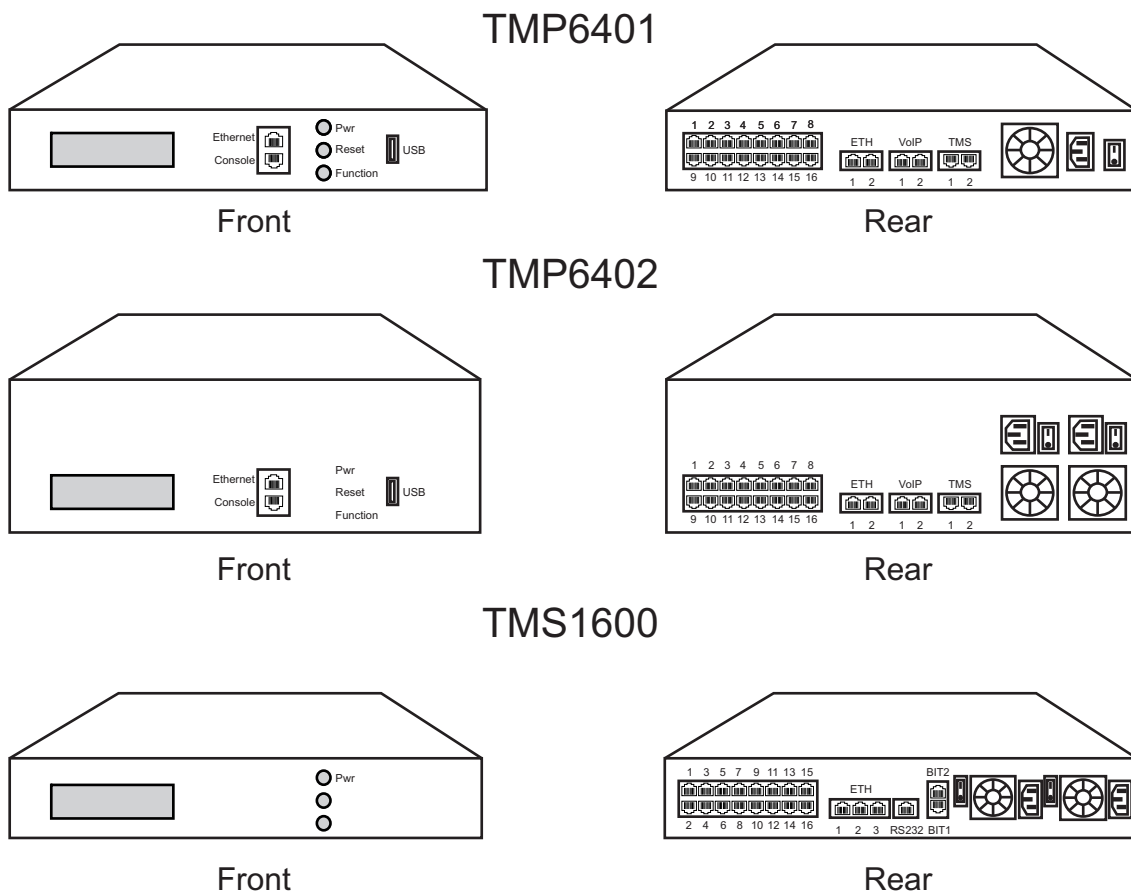

Figure 1.1 TMP6400, TMP6402, and TMS1600 seen from front and rear.

1.2 Installation Prerequisites

In order for the Tmedia system installation to proceed without interruption, it is important that you verify that you have on hand all of the necessary materials. Prior to beginning the installation, you should have prepared for the following:

- Adequate space for the installation of your Tmedia system. Consider that you will need to mount the Tmedia units on one or more 19" customer-provided equipment racks.
- Adequate power supply and power connections. In order to guarantee an uninterrupted supply, the Tmedia units must be powered by a dedicated power source. Consider that each Tmedia unit will require one to two power connections in addition to PCs, servers, and Ethernet switches. Tmedia units (other than 2U DC-powered units) are not shipped with power cords and therefore you will need to plan for your power cable requirements.
- In order to run your telecom applications on the TMP6400, you will need to have purchased an adequate number of licenses for the features that you will use.

In addition, you will need the following equipment:

Gigabit Ethernet Switches

Two gigabit Ethernet switches must be used to support full control redundancy. In its lab studies, TelcoBridges has not encountered problems with a large variety of switches available in the market. The following is a list of some switches that TelcoBridges has used:

- Dell Powerconnect 2708, 8 gigabit Ethernet ports
- Dell Powerconnect 2716, 16 gigabit Ethernet ports
- Netgear GSM7324, Layer 3 managed, 24 gigabit Ethernet ports

1.3 Preventing Electrostatic Discharge Damage

Electrostatic discharge (ESD) can damage equipment and impair electrical circuitry. It may occur if electronic printed circuit cards are improperly handled and may cause complete or intermittent failure.

Attention Always follow ESD prevention procedures when removing and replacing modules:

- Ensure that the TelcoBridges Tmedia units are electrically connected to earth ground.
 - Wear an ESD-preventive wrist strap and ensure that it makes good contact with your skin. Connect the wrist strap clip to an unpainted surface of the Tmedia unit or the grounded equipment rack in order to channel away all ESD voltage safely to ground. To guard against ESD damage and shocks, the wrist strap and cord must be in proper working condition.
 - If no wrist strap is available, and you must work with the Tmedia units, ground yourself by touching a metal part of the chassis.
-

1.4 Recommended Reading

This document assumes that you are well versed in the installation of TelcoBridges Tmedia units and have been trained to work with the equipment. If you have any technical questions, please contact TelcoBridges technical support or send an E-mail to support@telcobridges.com.

Other documents exploring various aspects of the Tmedia system are available on the TelcoBridges TB Wiki at: http://docs.telcobridges.com/mediawiki/index.php/Main_Page

Chapter 2 Equipment Connections

This chapter provides the procedures for the connection of a TMP6400 and TMS1600 to a Tmedia control network and their interface with a PSTN and IP network. Topics covered are:

- Verifying the list of materials
- Rack mounting the Tmedia equipment
- Connecting to the Tmedia Control network
- Connecting to the VoIP network
- Connecting to a PSTN Network
- Connecting the TMP6400 to the TMS1600
- Power Up

2.1 Package Contents

You will have received one or more TMP6400s and optionally one or two TMS1600s. The TMP6400 is the telecom platform on which you will run your telecom applications. The TMS1600, although not a requirement for your network, provides you with the scalability to build large-scale carrier-grade VoIP and Telecom systems.

2.1.1 TMP6400 Package Contents

In the TMP6400 box, you will find:

- One TMP6400
- One set of mounting brackets with screws. These are used for the mounting of a TMP6400 on a 19" rack.
- One DB-9 to RJ-45 adapter. Allows you to interface the serial port of your computer with the RJ-45 console port of the TMP6400. See pinout description in Section 2.4.3 "Connecting to the Serial Port of the Tmedia Unit" on page 14.
- SCSI cables and patch panels. This is optional and only provided if the PSTN interface on your TMP6400 features SCSI connectors.
- Three RJ45 CAT5 Ethernet straight cables (male-male), three meters in length. One can be used to connect the console port to a terminal. The remaining two cables can be used to connect to VoIP networks or to the Tmedia Control network.
- One warranty sheet
- One packing slip
- One TMP6400 Quick Installation guide.
- For 2U DC units, one pair of DC power cords is provided.

Not included with the TMP6400:

- RJ45 shielded CAT7 Ethernet cross-over cables (male-male). These are used for the connection between the TMP6400 and the TMS1600. This connection is referred to as the Tmedia Switch network.
- A power cord. Used to supply power to the TMP6400. If your model features redundant power supplies, then you will need two AC power cords. If your model features a DC power supply, then you will need one or two DC power cord(s), depending on the unit.
- A 19" equipment rack. You will use a standard 19" wide equipment rack to install the TMP6400s and TMS1600s.

2.1.2 TMS1600 Package Contents

In the TMS1600 box, you will find:

- One TMS1600
- One set of mounting brackets with screws. This is used for the mounting of a TMS1600 on a 19" rack
- One DB-9 to RJ-45 adapter. Allows you to interface the DB9 COM port of your computer with the RJ-45 COM port of the TMP6400
- Four RJ45 shielded CAT7 Ethernet cross-over cables (male-male). One cable is used for each connection between the TMS1600 and a TMP6400.
- One warranty sheet
- One packing slip
- One TMS1600 Quick Installation guide. A one- or two-page sheet that provides a pictorial view of equipment setup.

Not included with the TMS1600:

- A power cord. This is used to supply power to the TMP6400. You will need two AC power cords. If your model features a DC power supply, then you will need two DC power cords.
- A 19" equipment rack. You will use a standard 19" wide equipment rack to install the TMP6400s and TMS1600s.

Note You may only need one 19" rack for the installation of the Tmedia hardware. Refer to section Section 2.2.2 "Vertical Placement of Tmedia Equipment" on page 8

2.2 Rack mounting the Tmedia Equipment

The Tmedia hardware, consisting of one to 16 TMP6400s and optionally one to two TMS1600s are mounted on customer provided equipment racks using the mounting hardware packaged in the box.

2.2.1 Prerequisites

To rackmount the Tmedia equipment, you will need:

- One or more 19" customer provided equipment racks. Each rack must be solidly anchored to the floor with appropriate support at the top of the racks.
- Climate controlled room: 0 to +50 Celsius, 0 to 95% non-condensing humidity.

2.2.2 Vertical Placement of Tmedia Equipment

The Tmedia units are housed in either a 1U or 2 U chassis, as tabulated in table 2.1 on page 8. It is important that you provide for enough room on the equipment rack to allow for the installation of each Tmedia unit. Consider the available space on your equipment rack and the individual heights of each Tmedia unit. Due to the rear-exhaust heat vents and the efficient heat dissipation design, there is no need to leave any physical vertical space between the placement of the Tmedia units on the equipment rack.

Table 2.1 Tmedia Physical Height

Tmedia Model Number	Vertical Height
TMP6401	1U
TMP6402	2U
TMS1600	1U
TMP6400 Patch Panels ^a	1U
Gigabit Switches ^b	1U (or more)
Control Servers ^c	1U (or more)

a. TMP6400s configured with a 32 to 64 T1/E1 TDM module require one patch panel for each 32 E1/T1 line grouping.

b. Verify the manufacturer specifications for placement and spatial requirements.

c. Verify the manufacturer specifications for placement and spatial requirements. Depending upon the server that you will use the vertical height may range beyond a 1U size.

2.2.3 Mounting the Tmedia Hardware

The Tmedia hardware is mounted on the 19" equipment rack using the angle brackets and screws provided in the box. To mount the hardware, proceed as follows:

To mount the Tmedia hardware proceed as follows:

1. Using two metal screws, attach one angle bracket to the front, left-hand side of each Tmedia unit when viewed from the front, as shown in figure 2.1 on page 9. Repeat the same for the angle bracket on the right-hand side. Repeat this procedure for each Tmedia unit.
2. Starting with the TMP6400s, start mounting equipment at the top-most position of the rack, keeping in mind the space required on the equipment rack as described in Section 2.2.2 "Vertical Placement of Tmedia Equipment" on page 8. Repeat this step until all of the Tmedia units have been mounted on the equipment rack(s).

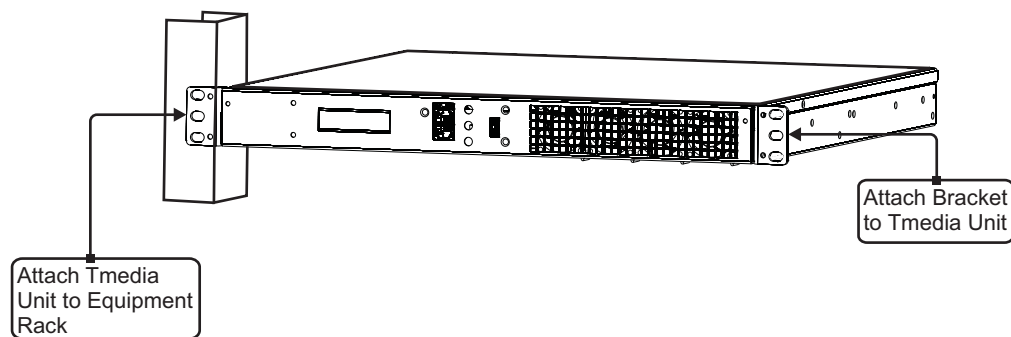

Figure 2.1 Mounting the Tmedia Hardware

2.3 Connecting to the Tmedia Control Network

The Tmedia control network enables the Toolpack application and stream servers to control the TMP6400s using a Gigabit Ethernet switch. It is strongly recommended that an additional Ethernet Switch be used to provide full control redundancy with one Ethernet link active and the other in a hot standby mode.

2.3.1 Prerequisites

To connect the TMP6400s to the Tmedia Control network, you will need:

- Customer provided gigabit Ethernet switch. A second one is required to support full Tmedia control network redundancy.
- One CAT5 Ethernet straight cable with RJ45 male-male terminations for each TMP6400.
- If your Tmedia system features a second Tmedia Control network link, you will require an additional CAT5 Ethernet straight cable with RJ45 male-male terminations for each TMP6400.

2.3.2 Interconnections

The TMP6400s are connected to the Tmedia Control network by one or, optionally, two Gigabit Ethernet network links, as shown in figure 2.2 on page 11.

To connect the TMP6400s to the Tmedia control network:

- 1. Start with the TMP6400 at the topmost position of the equipment rack and connect a CAT5 Ethernet straight cable with RJ45 male-male terminations to ETH1 at the rear of the TMP6400. Connect the other end of the same CAT5 cable to the Gigabit Ethernet switch.
- 2. If your system employs a second Gigabit Ethernet switch for control redundancy, connect a second CAT5 Ethernet straight cable to ETH2 at the rear of the TMP6400. Connect the other end of the same CAT5 cable to the second Gigabit Ethernet switch.
- 3. Repeat steps 1-2 for each TMP6400 and TMS1600 until they have all been connected to the Gigabit Ethernet switch(es).

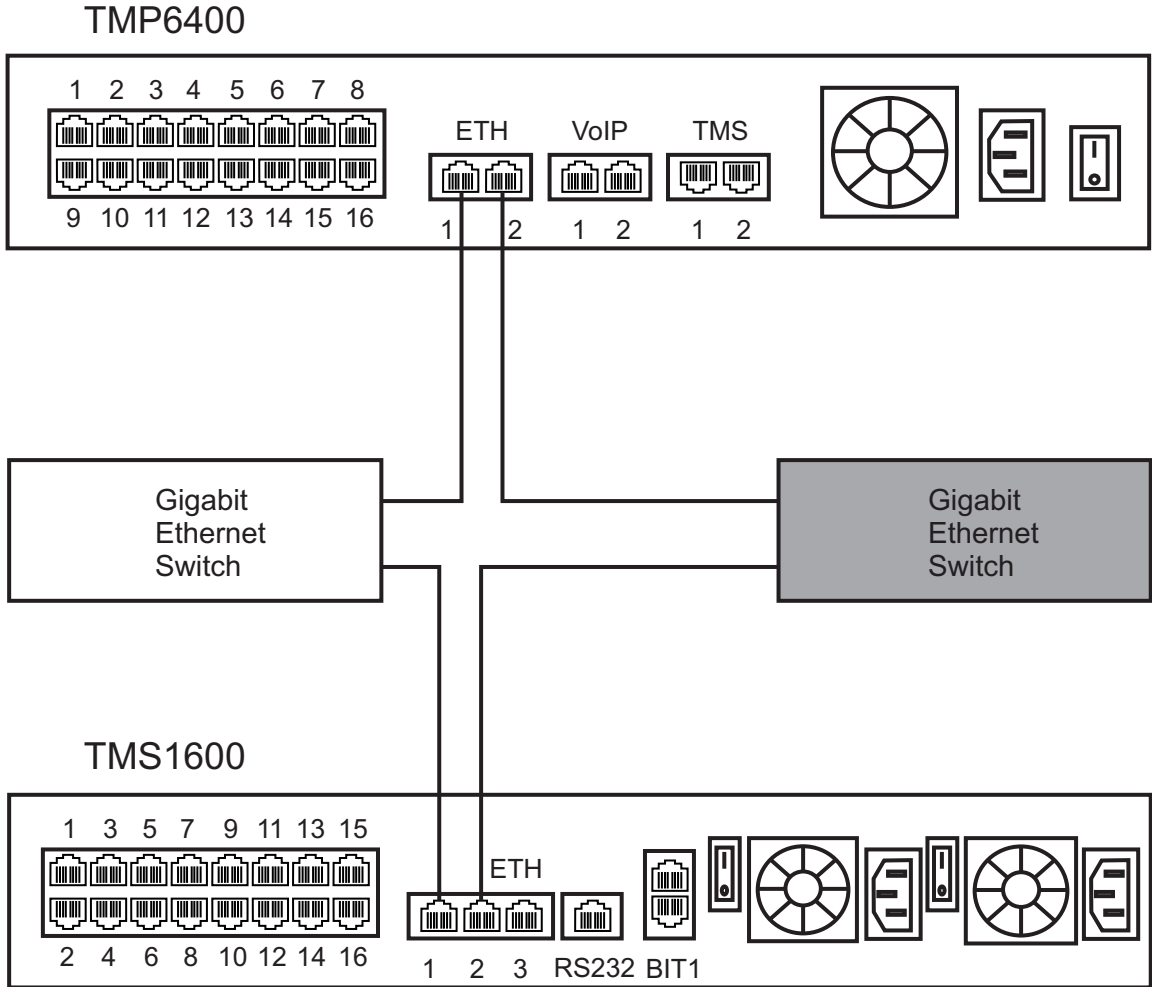

Figure 2.2 Connecting to the Tmedia Control Network

2.4 Connecting to the VoIP Network

The TMP6400 features dual GigE for connection to different VoIP networks. This provides two access points to handle VoIP traffic.

Note: **Certain configurations of the TMP6400 will exceed 100 Mbps, therefore 1000 Mbps is recommended.**

2.4.1 Prerequisites

To connect the TMP6400s to the VoIP network, you will need:

- Gigabit Ethernet switch. A second one is required to support redundancy of the VoIP interface.
- One CAT5 Ethernet cable with RJ45 male-male terminations for each TMP6400.
- If your Tmedia system features a second VoIP network link, you will require an additional CAT5 Ethernet cable with RJ45 male-male terminations for each TMP6400.

2.4.2 Interconnections

The TMP6400s are connected to the VoIP network by one or optionally two Ethernet GigE network links, as shown in figure 2.3 on page 13.

To connect the TMP6400s to the VoIP network:

1. Start with the TMP6400 at the topmost position of the equipment rack and connect a CAT5 Ethernet cable to VoIP1 at the rear of the TMP6400. Connect the other end of the same CAT5 cable to the Gigabit Ethernet switch.
2. If your system has a second VoIP access point, connect a second CAT5 Ethernet cable to VoIP2 at the rear of the TMP6400. Connect the other end of the same CAT5 cable to the second Gigabit Ethernet switch.
3. Repeat steps 1-2 for each TMP6400 until they have all been connected to the Gigabit Ethernet switch(es) for the VoIP network.

TMP6400

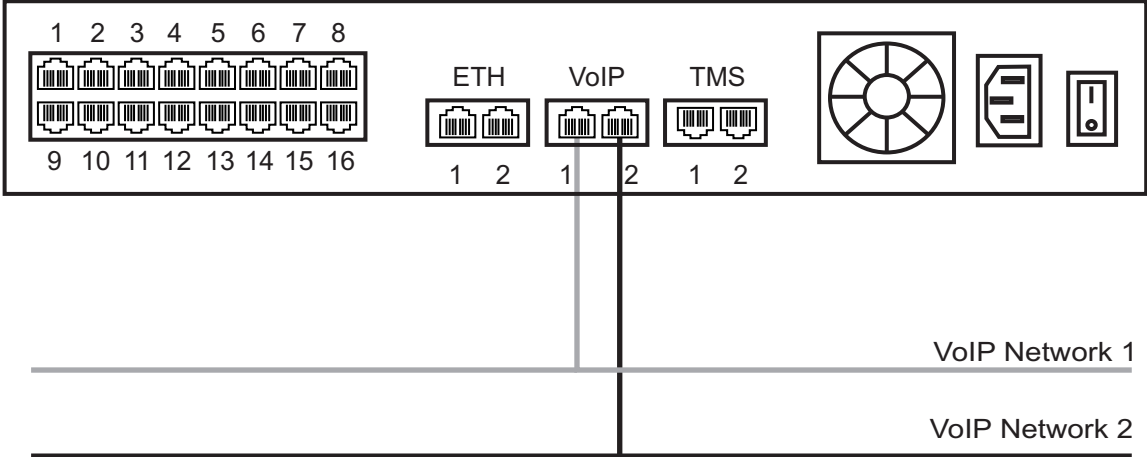

Figure 2.3 Connecting to the VoIP Network

2.4.3 Connecting to the Serial Port of the Tmedia Unit

To communicate with the Tmedia control network, you must first physically connect your computer port to the serial port of a Tmedia unit and configure the initial network settings that will enable communication with all of the Tmedia units of your network.

To connect to the serial port of a Tmedia unit:

1. Connect a RJ45 CAT5 (male-male) straight cable (supplied with unit) between the com port of your computer and the serial port of the Tmedia unit as shown in figure 2.4 on page 14. See Section 2.6 “Console pinout” on page 15 for a RJ-45 pinout description.
2. If your computer’s serial port features a DB9 connector, use the DB9 to RJ45 adapter supplied with your Tmedia unit. If your computer's serial port features a USB connector, you will need to provide a USB to DB9 adaptor. Refer to figure 2.5 on page 14.

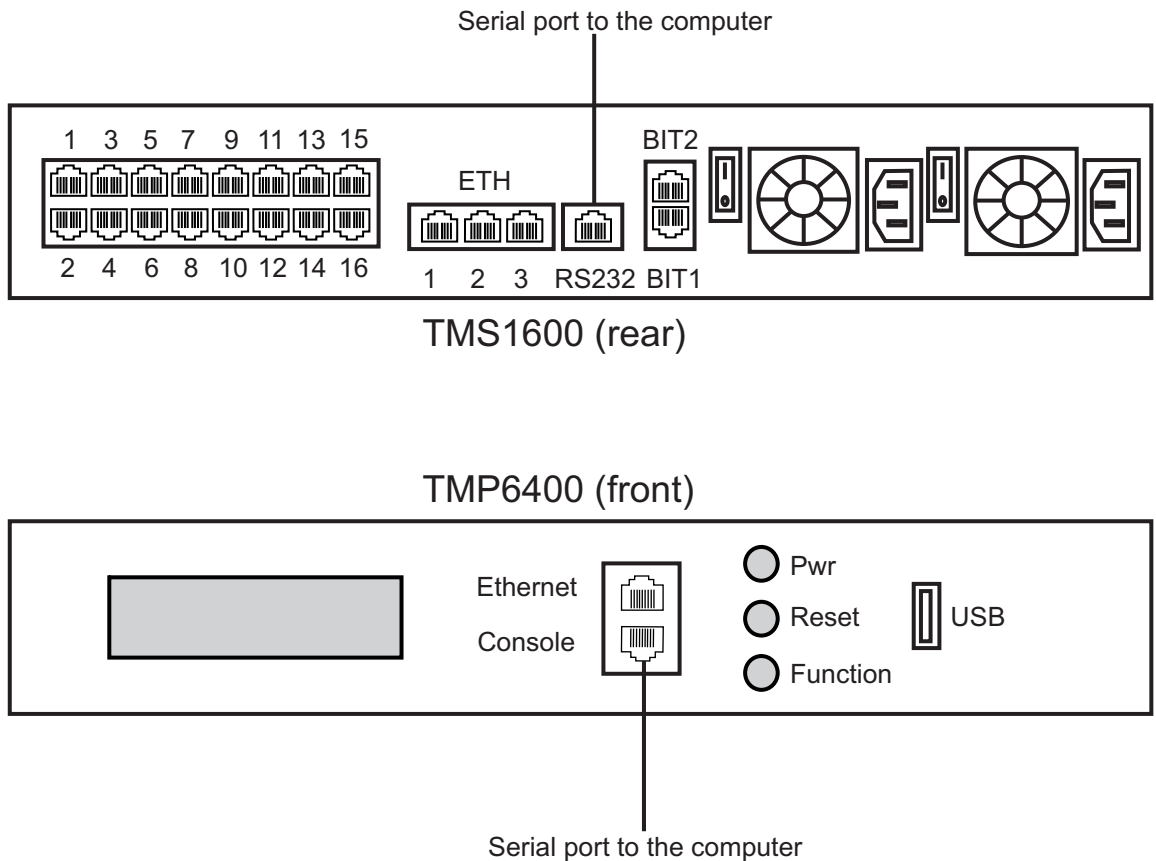

Figure 2.4 Computer to Tmedia Unit Serial Port Connection

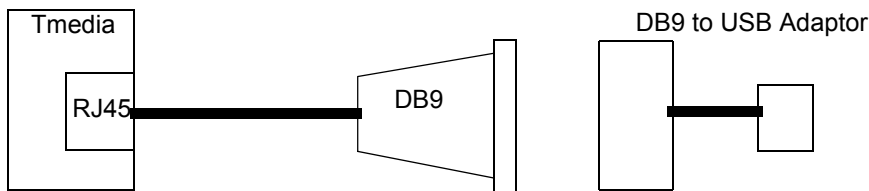

Figure 2.5 Conceptual View of a Serial Connection from the Tmedia unit to a Computer

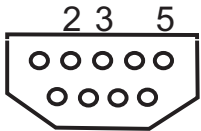
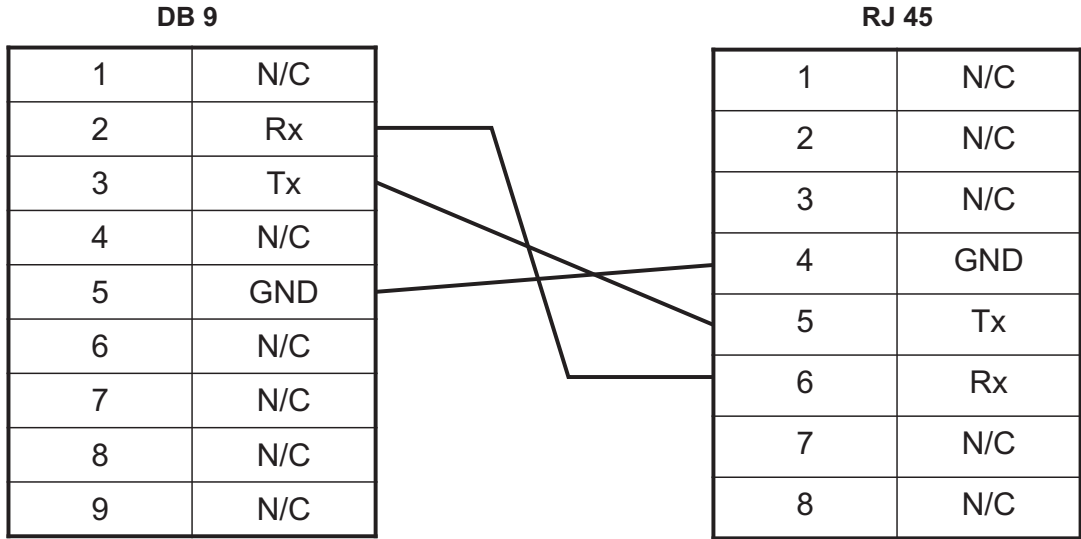

Figure 2.6 Console pinout

2.5 Connecting to the PSTN

The TMP6400 features a variety of interfaces to the PSTN network. Each TMP6400 that makes connection with the PSTN will feature a PSTN interface.

2.5.1 Prerequisites

To connect the TMP6400s to the PSTN network, you must comply with one of the following:

- Your TMP6400 features 16 modular 8-conductor RJ48 type jacks for connection to T1/E1/J1 lines. You will need one cable for each (T1/E1/J1) interface on the TMP6400.
- Your TMP6400 features SCSI connectors for connection to T1/E1/J1 lines. You will require one patch panel for each 32 line grouping of T1/E1/J1 line interfaces on the TMP6400.
- Your TMP6400 features BNC connectors for connection to DS3 lines. You will require two coaxial cables for each DS3 interface.
- Your TMP6400 features electrical or optical STM 1 connectors. You will require two fibre optic cables for the STM 1 interface of the TMP6400.

2.5.2 RJ48 Type Interface (T1/E1/J1)

A TMP6400 with 16 RJ48 type ports enables the connection to T1/E1/J1 lines. The termination impedance is set at 100 ohms for T1 lines and 120 ohms for E1 lines. It is possible to connect an external balun in order to convert to 75 ohms. See figure 2.7 on page 17

Note All ports may not be active. T1/E1/J1 ports are activated by software license; the number of active ports depends on the licenses purchased.

To connect the TMP6400 (RJ48 type) to the PSTN:

1. Start with port 1 located at the top and left-most position. Connect one cable between this port and the T1/E1/J1 line (figure 2.7 on page 17).
2. Repeat step 1, using the next available port.

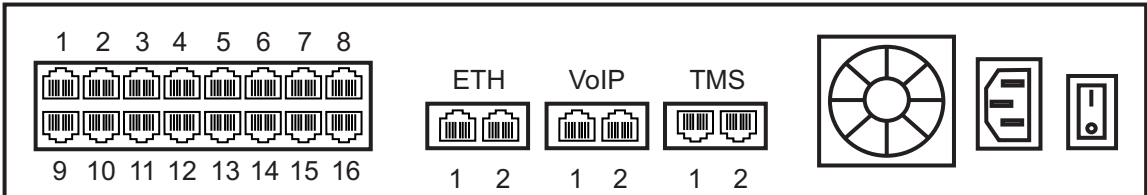

Figure 2.7 16-Port Interface to the PSTN

2.5.3 SCSI Interface (T1/E1/J1)

A TMP6400 with 4 SCSI connectors enables the connection to T1/E1/J1 lines. The termination impedance is set at 120 ohms. It is possible to connect an external balun in order to convert to 75 ohms. See figure 2.8 on page 19

Note All ports may not be active. T1/E1/J1 ports are activated by software license; the number of active ports depends on the licenses purchased.

To connect the TMP6400 (SCSI) to the PSTN:

1. Start with the SCSI ports 1-16 located at the bottom right as shown in figure 2.8 on page 19. Connect one SCSI cable between this port and SCSI patch panel number 1, ports 1-16. Connect SCSI ports 17-32 to patch panel number 1, ports 17-32.
2. Repeat step 1, using lines 33-64 and a second patch panel. Connect lines 33-48 to patch panel 2, port 1-16. Connect lines 49-64 to patch panel 2, ports 17-32.

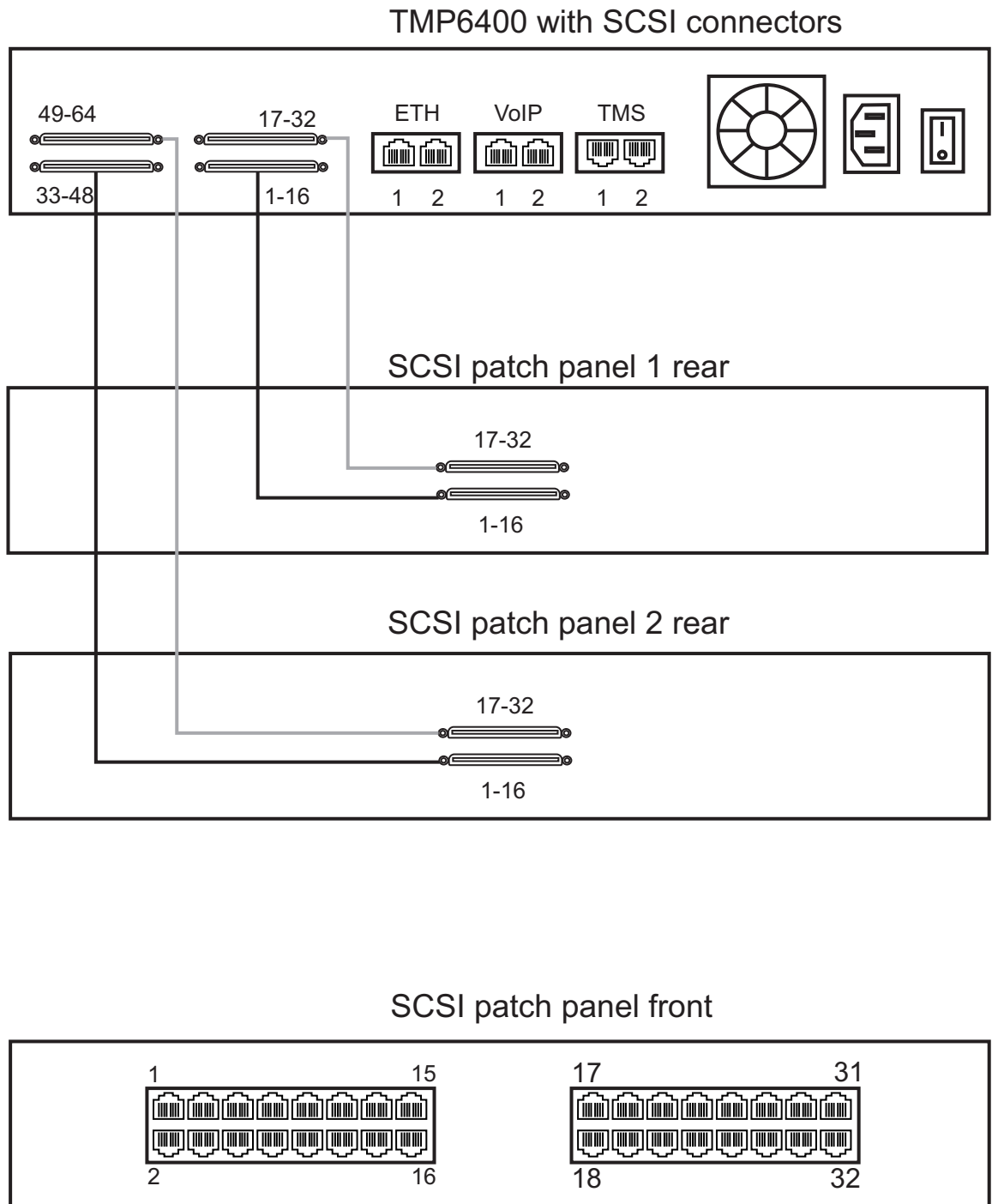

Figure 2.8 SCSI Interface to the PSTN

2.5.4 Dual BNC Interface (DS3)

A TMP6400 with 3 sets of BNC connectors enables the connection to DS3 lines. See figure 2.9 on page 20

Note All ports may not be active. DS3 ports are activated by software license; the number of active ports depends on the licenses purchased.

To connect the TMP6400 (DS3) to the PSTN:

1. Start with the Dual BNC port pair #1 (right-most) as shown in figure 2.9 on page 20. Connect one pair of BNC cables between this port and the DS3 line.
2. Repeat step 1, using the next available pair of BNC PSTN interface ports.

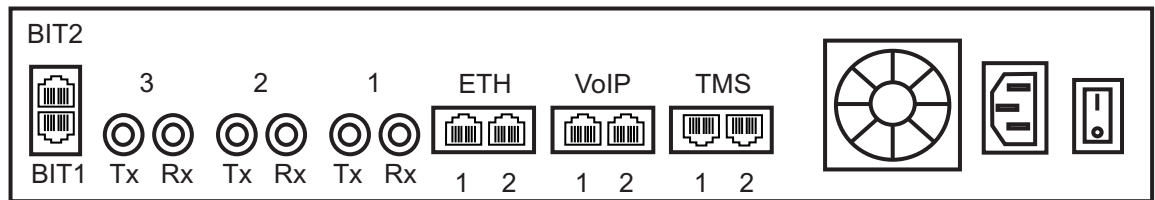

Figure 2.9 DS3 Interface to the PSTN

2.5.5 Optical Interface (OC3/STM-1)

A TMP6400, with one main and one backup OC3 or STM-1 port enables connection to OC3/STM-1 lines. See figure 2.10 on page 21. Refer to table 2.2 on page 21 for a listing of optical interfaces. The default OC3/STM-1 connection is SMF, intermediate reach, (SFP-OC3-IR1) 1310 nm with LC type connectors.

Note Please make certain that the correct model is selected at the time of ordering. If your installation requires a different model from the one that has been provided, you must replace it.

Automatic Protection Switching

The APS port is used for OC3/STM-1 redundancy. Switchover occurs automatically based on configurable parameters. It is recommended that APS be used if the installation provides this feature.

To connect the TMP6400 (Optical Interface) to the PSTN:

1. Connect a fiber optic cable between the Main port and OC3/STM-1 line, as shown in figure 2.10 on page 21.
2. Connect a fiber optic cable between the APS port and OC3/STM-1 line.

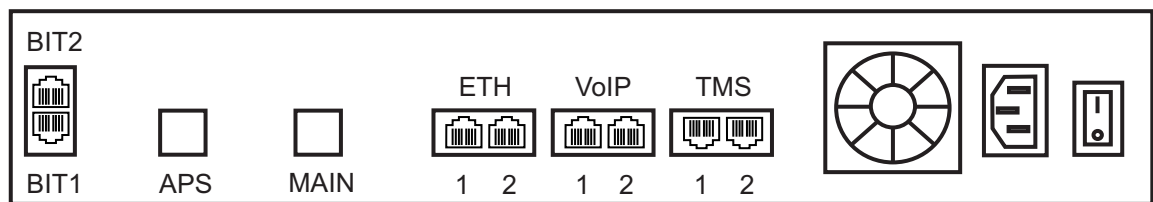

Figure 2.10 Optical Interface to the PSTN

Table 2.2 Optical Interfaces

Transceiver Model	Description	Spec	Mode	Type	Range (Km.)	Wavelength (NM)	Connection
SFP-OC3-IR1	OC3/STM1	Hot Pluggable	Single-mode	Intermediate reach	15	1310	LC
SFP-STM1E	STM1E (Electrical)	Hot Pluggable	75 ohms Cooper	Max 180m	^a	NA	DIN (mini-coax)

a. Variable range

2.6 Connecting the TMP6400s to the TMS1600

The TMS1600 enables you to scale your Tmedia system by interfacing as many as 16 TMP6400s with its Tmedia Switch network, building a non-blocking system of up to 32,768 channels. A second TMS1600 provides your system with an active/standby high availability architecture.

2.6.1 Prerequisites

To interconnect the TMP6400s with the TMS1600, you will need:

- One CAT7 shielded Ethernet crossover cable with RJ45 type male-male terminations for each TMP6400 connected to the TMS1600.
- If your Tmedia system features a second TMS1600, you will require an additional CAT7 shielded Ethernet cable with RJ45 male-male terminations for each TMP6400.

2.6.2 Interconnections

The resources of the TMP6400s are made available to each other by the connection to one or optionally two TMS1600s, as shown in figure 2.12 on page 23. See figure 2.11 on page 22 for an Ethernet crossover wiring diagram.

To interconnect the TMP6400s:

1. Start with the TMP6400 at the topmost position of the equipment rack and connect a CAT7 shielded Ethernet crossover cable to TMS1 at the rear of the TMP6400 figure 2.12 on page 23. Connect the other end of the same CAT7 cable to the first port of the first TMS1600.
2. If your system employs a second TMS1600, connect a second CAT7 shielded Ethernet crossover cable to TMS2 at the rear of the TMP6400 figure 2.12 on page 23. Connect the other end of the same CAT7 cable to the first port of a second TMS1600.
3. Repeat steps 1-2 for each TMP6400 until they have all been connected to the TMS1600.

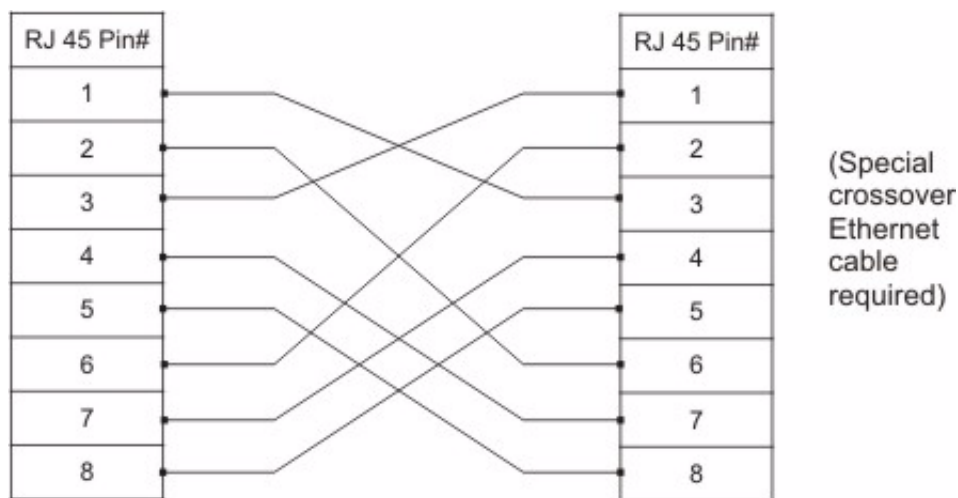

Figure 2.11 Ethernet Crossover Cable

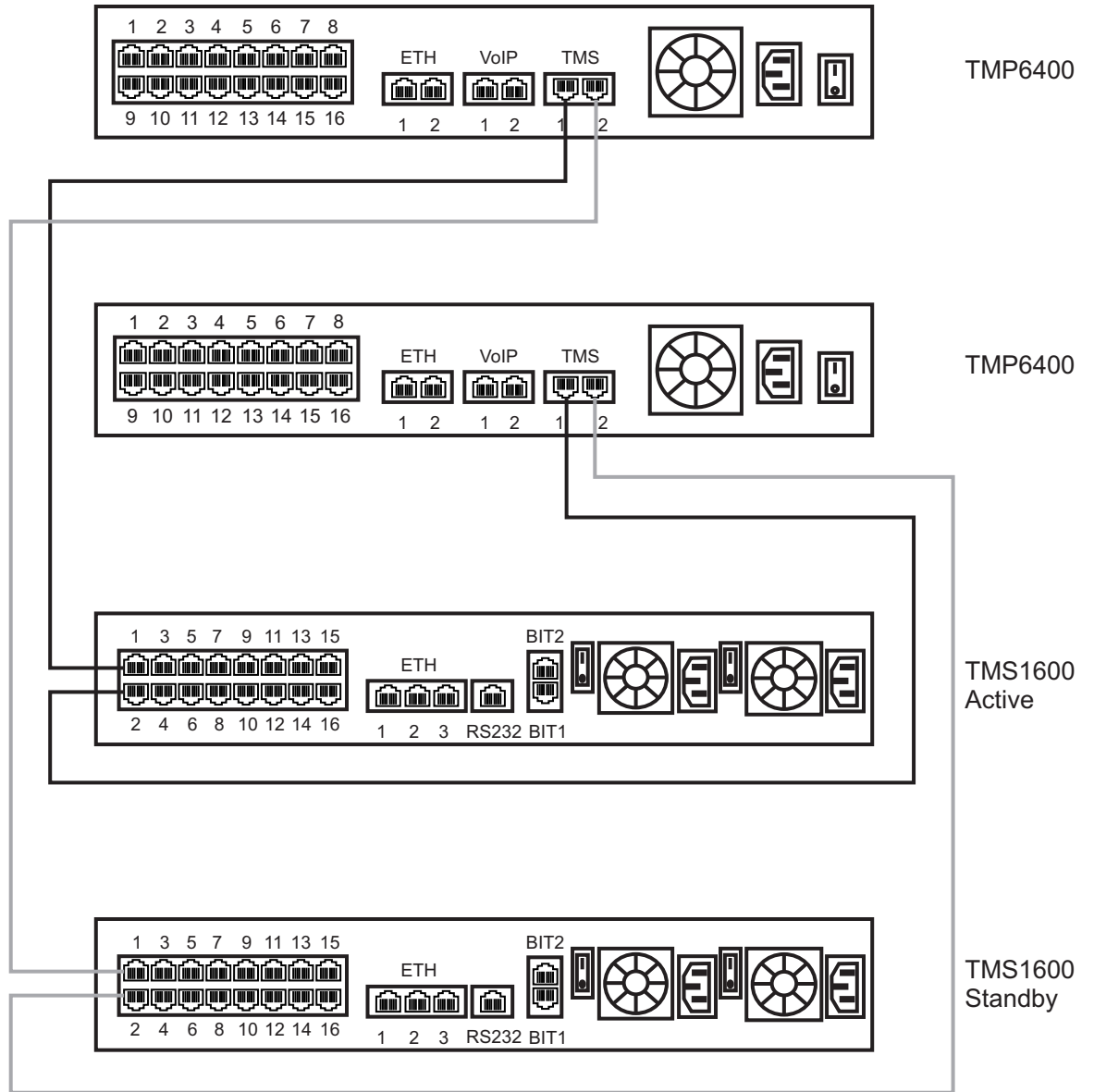

Figure 2.12 Example of Interconnecting 2 TMP6400s to an active and standby TMS1600

2.7 Interconnecting Two TMP6401s or TMP6402s

When only two Tmedia units, such as a TMP6401 or TMP6402, need to be interconnected, the TMS1600 is not required. Simply connect the TMS1 ports of each unit together using an CAT7 shielded cross-over cable with RJ45 male-male terminations. Do the same for the TMS2 ports of each unit. See figure 2.13 on page 24.

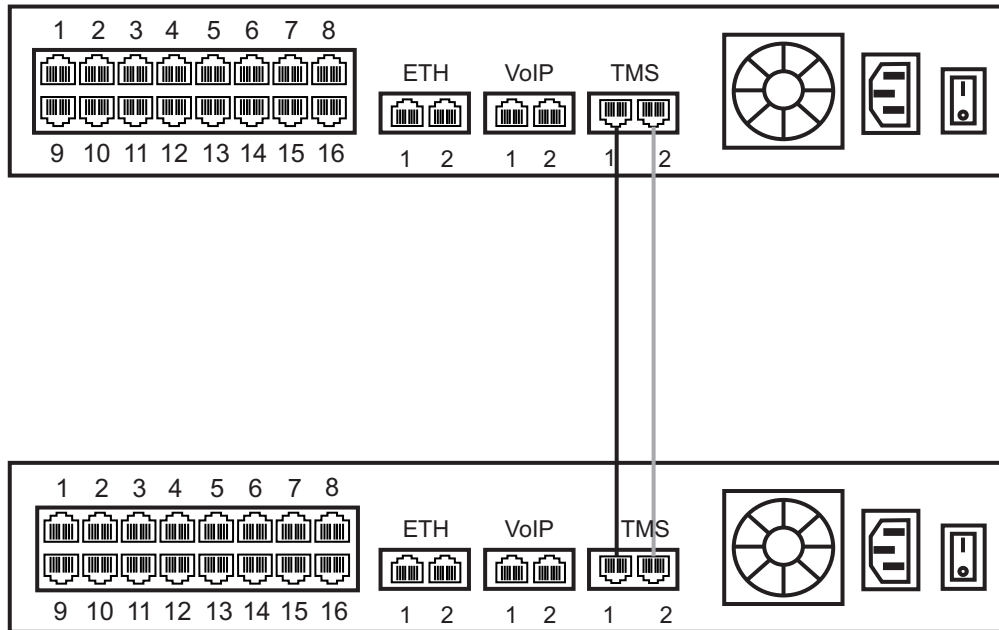

Figure 2.13 Interconnecting two TMP6400 units.

2.8 Powering Up

Each Tmedia unit is furnished with one or optionally two AC or DC power connections. Only once all other equipment installation work has been completed should the Tmedia units be powered up.

2.8.1 Prerequisites

To power the Tmedia units, you will need:

- A power source, capable of powering all the Tmedia units.
- One power cable for each Tmedia unit. Optionally a second power cable is required if the Tmedia unit is furnished with a secondary power supply.

2.8.2 Connecting to AC Power

The Tmedia units are furnished with one or optionally two AC power connectors (figure 2.14 on page 26).

To connect the Tmedia units to AC Power:

1. Connect one AC power cable between the AC connector of the Tmedia unit and an AC supply. See figure 2.14 on page 26. If the Tmedia unit features a second AC connector, connect an additional AC power cable between this connector and an AC power supply. If the Tmedia unit features a second power supply and it is not connected to an AC power source, press the green button located at the rear of the unit to disable the audible alarm. See figure 2.14 on page 26. For a TMS1600, if a second power source is not connected, press the red button at the rear of the unit to disable the audible alarm.
2. Repeat step 1 for each Tmedia unit until they have all been connected to a power source.
3. Power up each Tmedia unit by turning on their AC power switches

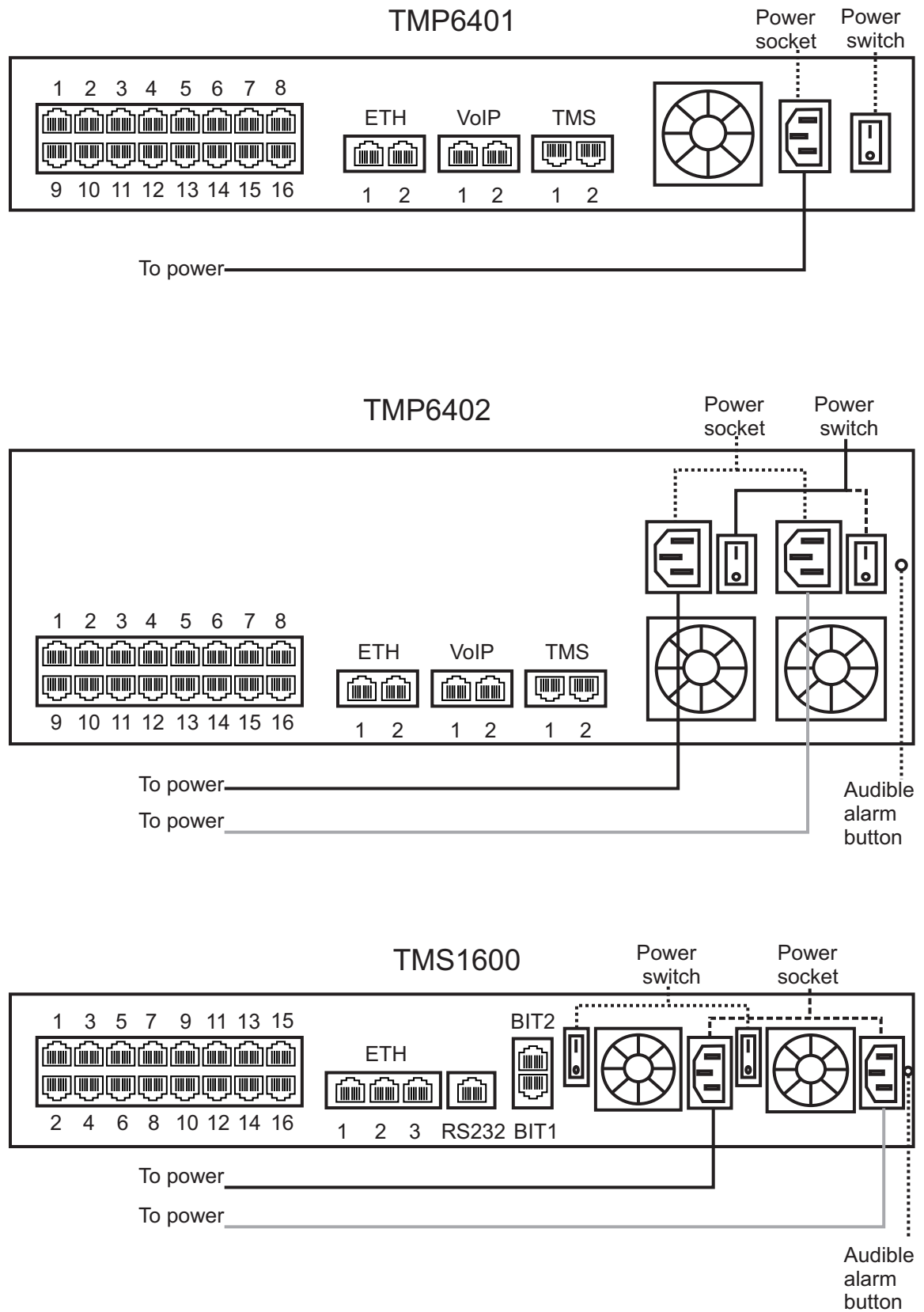

Figure 2.14 AC Power Connection

2.8.3 Connecting to DC Power

The Tmedia units are furnished with one or optionally two DC power connection ports. In addition, each DC powered Tmedia unit is supplied with a DC power cable. The connection of DC power is described for:

- TMP6401
- TMP6402
- TMP1600

To connect the TMP6401 to DC power:

1. Connect a ground wire to the ground lug located at the rear of the TMP6401, as shown in figure 2.17 on page 29.
2. Connect a 14 AWG wire between the positive terminal of a DC power source and the terminal on the TMP6400 labelled as $\overline{\text{---}}$.
3. Connect a 14 AWG wire between the negative terminal of a DC power source and the terminal on the TMP6400 labelled as 48V.
4. Turn on the DC power source.

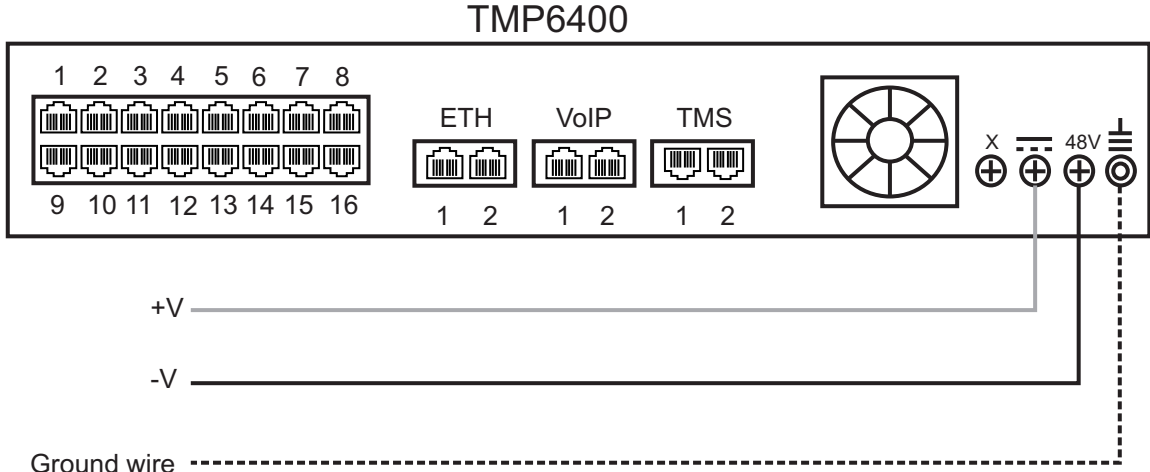

Figure 2.15 TMP6401 DC wiring diagram

To connect the TMP6402 to DC power:

1. Connect the DC cable supplied with the TMP6402, as shown in figure 2.16 on page 28, to the DC outlet at the rear of the TMP6402.
2. Connect the red lead of the DC power cable to the positive terminal of the DC power source, as shown in figure 2.16 on page 28.
3. Connect the black lead of the DC power cable to the negative side of the DC power source.
4. Repeat steps 1-3 for the second power DC power source.
5. Turn on the DC power source.

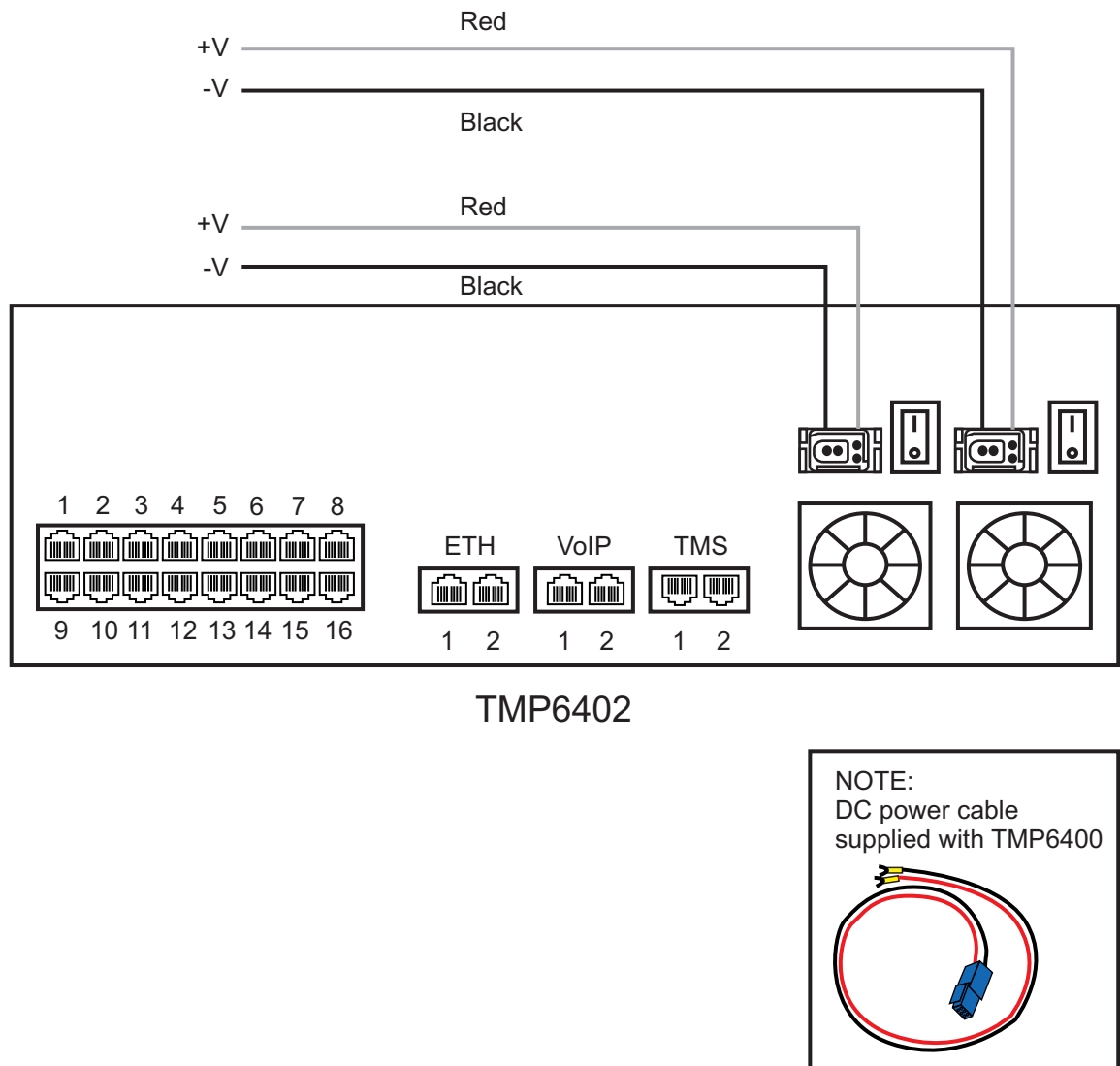

Figure 2.16 TMP6402 DC wiring diagram

To connect the TMS1600 to DC power:

- 1. Connect a ground wire to the ground lug located at the rear of the TMS1600, as shown in figure 2.17 on page 29.
- 2. Connect a 14 AWG wire between the positive terminal of a DC power source and the terminal on the TMP6400 labelled as \oplus .
- 3. Connect a 14 AWG wire between the negative terminal of a DC power source and the terminal on the TMP6400 labelled as 48V.
- 4. Repeat steps 1-3 for the second DC power source.
- 5. Turn on the DC power source.

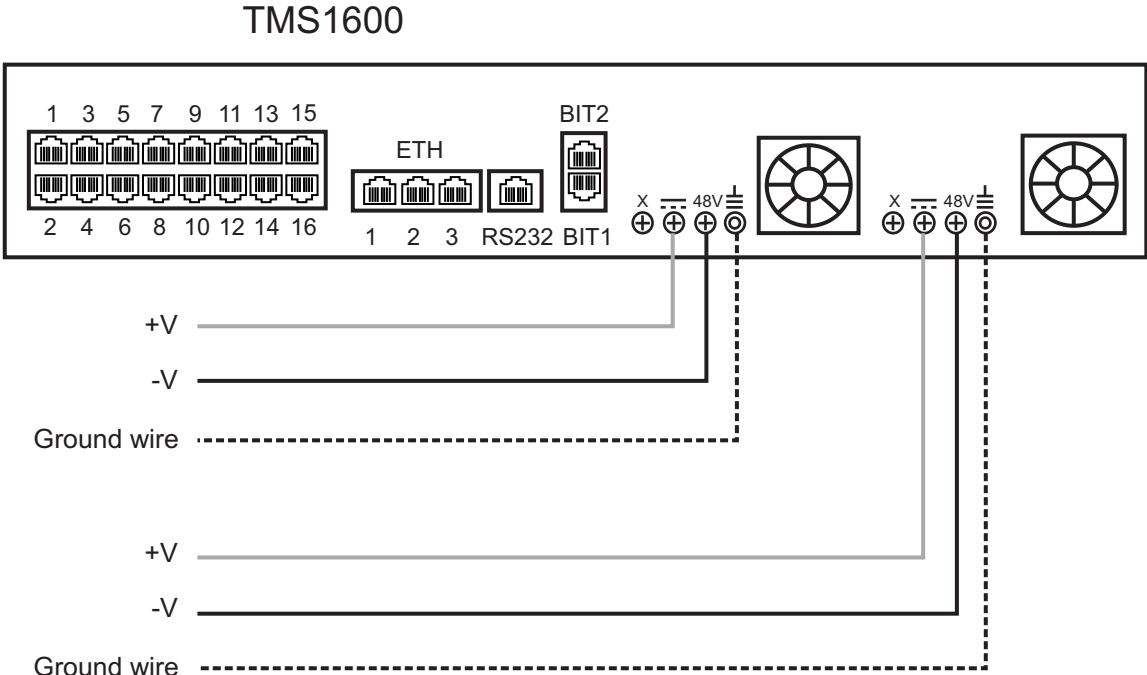

Figure 2.17 TMS1600 DC wiring diagram

2.8.4 Verifying the LED Status Indications

When all of the Tmedia units have been powered, verify the front panels of the units to determine that all indications are normal.

Once the Tmedia units have run successfully through their system boot procedures, the following will be displayed in an alternating fashion as described in Table 2.3 on page 30:

Table 2.3 Tmedia Unit Displays

Display Order	Display
First Screen	IP 0: <ip address of eth0. E.g. 192.168.0.2> IP 1: <ip address of eth1 E.g. 192.168.0.3>
Second Screen	<board type.. eg. TMP-STM1, TMS-16, TMP-DS3, TMP-16, TMP-32, TMP-64> <adapter name e.g. TB002821> <serial number e.g. TB002821> <release used e.g V2.2.0 RC1>

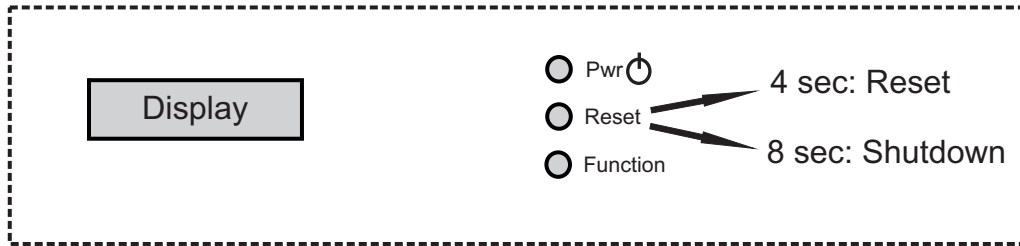

Figure 2.18 Front display and LEDs

Chapter 3 Initial System Configuration

This chapter provides the initial procedures that are required in order for you to be able to use the Tmedia Web portal to configure your Tmedia units.

The following topics are covered:

- Configuring the terminal emulation application
- Using the `set_boot` and `print_boot` commands
- Creating a shell password
- Applying changes
- Tmedia default IP addresses

3.1 Configuring the Terminal Emulator Application

Before communicating with the Tmedia control network, you must first configure a terminal emulator or console application to communicate with one of the Tmedia units in order to configure initial settings. Available terminal emulation software includes:

- HyperTerminal
- Putty
- Minicom

To configure the terminal emulator application:

1. Set the baud rate (bits per second) to **9600**
2. Set the data rate to **8 bits**
3. Set the parity to **None**
4. Set the stop bits to **1**
5. Set the flow control to **None**

3.2 Using the set_boot and print_boot Commands

The set_boot command can be used to modify certain settings and the print_boot command can be used to review the changes. Using the set_boot command, the System ID (also known as gateway port) can be configured.

Settings will be applied on the next reboot of the platform.

Alternatively, you can use the default IP address of ETH1 or ETH2 to configure the Tmedia units, see Section 3.5 “Tmedia Default IP Addresses” on page 38. To do this, connect a device on the same subnet as the default IP addresses and connect using Telnet.

Note **System ID** is also known as **UDP gateway port**.

To modify boot settings:

1. Using the Management Interface, type **set_boot** and press the **Enter** key to move to the next prompt

```

10.2.0.140 - PuTTY
0/tbgw>set_boot

Press <ENTER> to use the existing value,
or insert a new value and press <ENTER>.
active cfg (max 80 char)(<cfgname>)=TB2933_TEST? :
autoboot (y|n)=y? :
autofsload (y|n)=y? :
boottimeout (max=255)=5? :
gateway port (TBX_GW_PORT= 12358 )? :

Press <ENTER> to use the existing value,
or insert a new value and press <ENTER>.
adapter name (max 80 char)(<adaptername>)=TB002933? :
eth dhcp (y|n)=n? :
eth0 Ip Address (ipaddr)=10.2.0.140? :
eth0 Netmask (nmaddr)=255.255.255.0? :
eth0 Gateway (gwaddr)=10.2.0.1? :
eth1 Ip Address (ipaddr)=10.2.1.140? :
eth1 Netmask (nmaddr)=255.255.255.0? :
eth1 Gateway (gwaddr)=10.2.1.1? :
voip0 Ip Address (ipaddr)=10.2.2.140? :
voip0 Netmask (nmaddr)=255.255.255.0? :
voip0 Gateway (gwaddr)=10.2.2.1? :
voip1 Ip Address (ipaddr)=10.2.3.140? :
voip1 Netmask (nmaddr)=255.255.255.0? :
voip1 Gateway (gwaddr)=10.2.3.1? :
mgnt dhcp (y|n)=n? :
mgnt Ip Address (ipaddr)=172.31.5.140? :
mgnt Netmask (nmaddr)=255.255.255.0? :
mgnt Gateway (gwaddr)=172.31.5.1? :

List of available boot directories:
/
 licenses
 2_0_6.1
 02020101 (2_2_1.1)
 02010a01 (2_1_10.1)
 2_2_0.4
Curr Boot dir.....: /ffs/02020101/
Good Boot dir.....: /02020101
Next Boot dir.....: /02020101
nextbootdir (max 80 char)(<validbootdir>)=/02020101? :
0/tbgw>

```

The following prompts are displayed:

Prompt	Description
Adapter Name	Name of the Tmedia unit. This character string must uniquely identify the Tmedia unit. The default value is the serial number of the Tmedia unit.
DHCP	Dynamic IP address is used when the Tmedia unit is started. Currently not supported.
eth0/eth1/VoIP0/VoIP1: IP Address	When you are not using DHCP, the IP address is used as the static IP address for ports Ethernet 0 (ETH1), Ethernet 1(ETH2), VoIP0 (VoIP1), VoIP1 (VoIP2), and Management (Ethernet) of the Tmedia unit.

Prompt	Description
eth0/eth1/VoIP0/VoIP1: NetMask	When you are not using DHCP, the network mask is used for ports Ethernet 0, Ethernet 1, and VoIP0 of the Tmedia unit.
eth0/eth1/VoIP0/VoIP1: Gateway	When you are not using DHCP, the gateway address is used for ports Ethernet 0, Ethernet 1, and VoIP0 of the Tmedia unit. If you are planning to use the Tmedia unit in the same subnet as the host (i.e. you do not require access to an IP address outside the subnet), then the gateway can be set to '127.0.0.1'.
Active cfg	This allows a device to make use of multiple configurations.
autoboot: auto fpgaload	When set to "no", the device will stop booting after initial bootup sequence. This is used for debugging only, the default value is "yes".
Boot timeout	This is used to set the time lapse between the initial bootup sequence and the complete bootup. The default value for this setting is 5 seconds.
gateway port	(see previous page)
list of available Boot directories	This enables the user to manually switch between available software versions.

Note Each network interface (Eth0, ETH1, VoIP0, and VoIP1) must be on a different subnet. For example, if the netmask is 255.255.0.0 and the IP address of ETH0 is 192.168.1.10, the VoIP0 port cannot be on any IP address starting with 192.168.x.x.

Note Do not confuse the gateway port (also known as System ID) with the IP gateway address.

The gateway port is used to control the Tmedia units and TelcoBridges strongly recommends that this setting be left at its default value: 12358.

Tmedia units on the same gateway port will be automatically detected by any Toolpack application.

Different gateway ports can be useful for the segmentation of systems configured to operate on the same physical network and IP subnet. Make certain that all applications in the same system are configured to use the same values.

This is described in the Toolpack Installation guide; for further information, contact TelcoBridges Technical Support.

Note The management interface is reserved for future use.

To view the results of a set_boot command:

1. Type print_boot

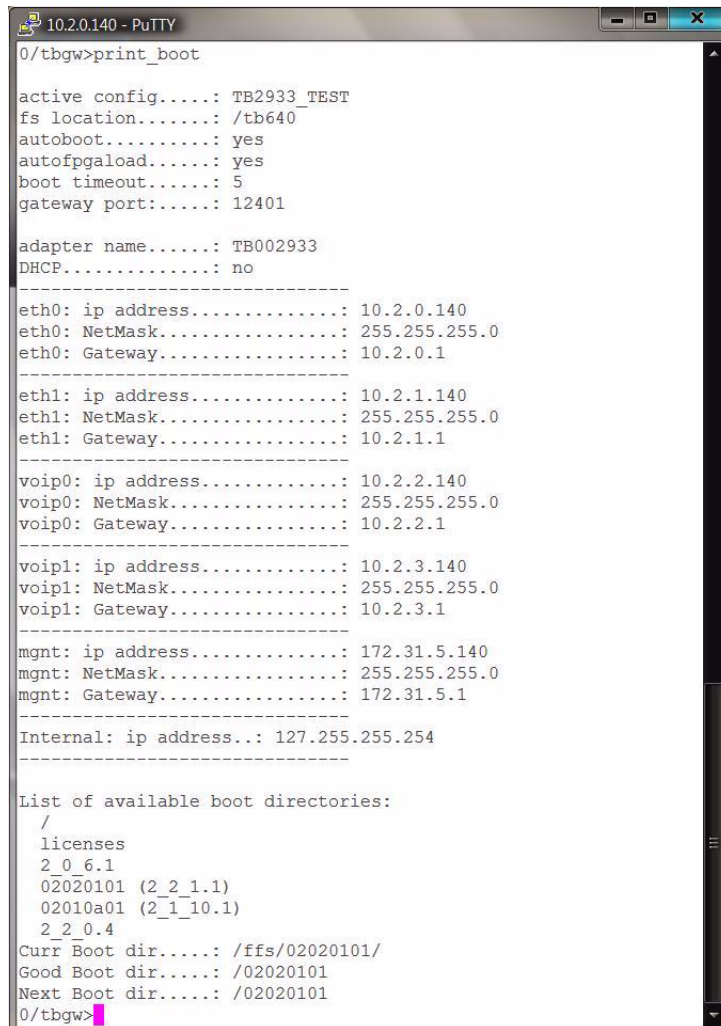

```
10.2.0.140 - PuTTY
0/tbgw>print_boot

active config.....: TB2933_TEST
fs location.....: /tb640
autoboot.....: yes
autofpgaload.....: yes
boot timeout.....: 5
gateway port.....: 12401

adapter name.....: TB002933
DHCP.....: no
-----
eth0: ip address.....: 10.2.0.140
eth0: NetMask.....: 255.255.255.0
eth0: Gateway.....: 10.2.0.1
-----
eth1: ip address.....: 10.2.1.140
eth1: NetMask.....: 255.255.255.0
eth1: Gateway.....: 10.2.1.1
-----
voip0: ip address.....: 10.2.2.140
voip0: NetMask.....: 255.255.255.0
voip0: Gateway.....: 10.2.2.1
-----
voip1: ip address.....: 10.2.3.140
voip1: NetMask.....: 255.255.255.0
voip1: Gateway.....: 10.2.3.1
-----
mgmt: ip address.....: 172.31.5.140
mgmt: NetMask.....: 255.255.255.0
mgmt: Gateway.....: 172.31.5.1
-----
Internal: ip address..: 127.255.255.254
-----

List of available boot directories:
/
 licenses
 2_0_6.1
 02020101 (2_2_1.1)
 02010a01 (2_1_10.1)
 2_2_0.4
Curr Boot dir.....: /ffs/02020101/
Good Boot dir.....: /02020101
Next Boot dir.....: /02020101
0/tbgw>
```

3.3 Creating a Shell Password

Access to the shell commands may be protected with a password.

Note By default, access to the shell commands is not password protected.

To create a password:

1. At the shell prompt, type **set_pass <your password>**.

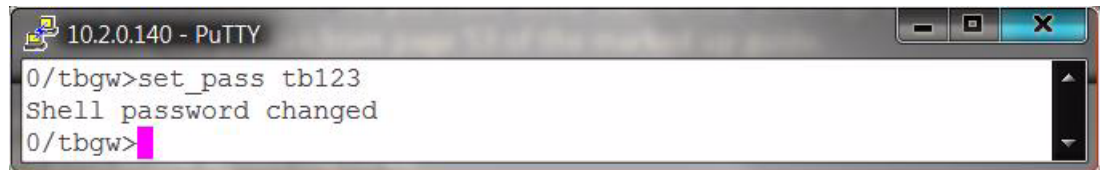

```
10.2.0.140 - PuTTY
0/tbgw>set_pass tb123
Shell password changed
0/tbgw>
```

2. Restart the Tmedia unit. This will reset the Tmedia unit and add the enable and disable shell password commands to the console commands list.

Once the shell password has been set, it cannot be changed unless you are in the **Enabled** mode. The enabled mode provides you with access to operation sensitive commands.

To enter the enabled mode:

1. At the shell prompt, type **enable <your password>**.

To clear the password mode:

1. At the shell prompt, type **set_pass** (without entering a password).

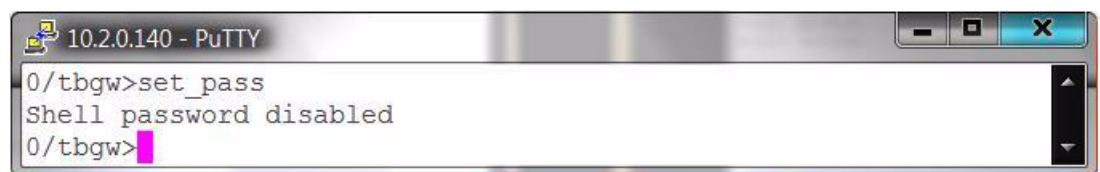

```
10.2.0.140 - PuTTY
0/tbgw>set_pass
Shell password disabled
0/tbgw>
```

To exit the enabled mode:

1. At the shell prompt, type **disable**.

3.4 Applying Changes

In order to apply all changes made, enter the following command:

```
reboot
```

This will restart the platform with the new settings taking effect.

3.5 Tmedia Default IP Addresses

All Tmedia units are shipped with default IP addresses, as follows:

- Eth0: ip address: 192.168.0.2
- Eth0: Netmask: 255.255.255.0
- Eth0: Gateway: 192.168.0.1
- Eth1: ip address: 192.168.0.3
- Eth1: Netmask: 255.255.255.0
- Eth1: Gateway: 192.168.0.1

Chapter 4 Toolpack Installation

This chapter provides a brief introduction of Toolpack software and provides a listing of the various versions of Toolpack Installation guides geared towards your specific operating system.

The following topics are covered:

- ToolPack operating system platforms
- Installation guidelines

4.1 ToolPack Operating System Platforms

TelcoBridges Toolpack software is designed to work with the following operating system families:

- Windows™
- Solaris™
- Linux®

Following is a list of supported operating systems:

- Cent OS 5, x86_32, x86_64
- RedHat Enterprise Linux 5 (RHEL5), x86_32, x86_64
- Debian 4, x86_64
- Fedora Core 7 (FC7) x86, x86_64
- Windows XP/Vista/Server 2003, x86_32
- Solaris 5.9, sparc_32
- Solaris 5.10, x86_32
- TBLinux, ppc 32 bits

Depending upon your choice of operating system, you must consult a Toolpack installation guide specific to your operating system. These documents are available on TelcoBridges TB Wiki at:

[Http://docs.telcobridges.com/mediawiki/index.php/installing_Toolpack](http://docs.telcobridges.com/mediawiki/index.php/installing_Toolpack)

4.2 Installation Guidelines

Follow the instructions of your Toolpack installation guide by first retrieving all the indicated software and then proceeding with its installation.

Chapter 5 System Upgrades

The TelcoBridges Tmedia units start up from a local system file located in flash memory. The flash memory is furnished with a version of firmware available at the time of production. If you are using Toolpack, verify that you have the required license and follow the upgrade instructions in the Toolpack Installation guide. Otherwise, you must install the firmware package that you will be using.

If you are unsure of which firmware release to install, please contact TelcoBridges customer support.

This chapter provides procedures related to the administration of firmware packages.

Note For users of Toolpack, the system will automatically perform any required upgrades.

The following topics are covered:

- Installing a firmware package
- Removing a firmware package
- Installing a new license

5.1 Installing a Firmware Package

To install a new firmware package on the local file system:

1. Start the installation tool (install) located in the OS-specific package in the /tb/bin/release/<proc-OS-arch>/ directory.
2. The installation tool should detect all available Tmedia units in the network. If more than one Tmedia unit is discovered, select the Tmedia unit to which the firmware package is to be installed.
3. Select option 20: Install a package.
 - 3a. When asked for the path of the package file, enter the path of the file "tbgw.pkg" for a TMP6400 or "tms.pkg" for a TMS1600. This is located in the package tb640-adapter.release.zip under /tb/bin.
 - 3b. When asked, enter the directory name in which the firmware package is to be installed. The default name will be the release number as the directory name. For example: "94-8_4".
 - 3c. When asked for the path of the license file, enter the path where you saved the license file (XX_TB000XXX_RELEASE_VX_XX_RCX_license.dat) that you received from the TelcoBridges support group.

It is important that you use the license file intended for the major version of the package. You must know the serial number of the TelcoBridges Tmedia unit to be able to choose the right license. For example, the license file WD_TB000103_RELEASE_V2_3_8_RC4_license.dat would be valid for a Tmedia unit with the serial number TB000103 and any release v2.3 package.
 - 3d. When asked to set the new package as next boot directory, select **True**.
4. Select option **99** to restart the Tmedia unit.

Note Should this, or any other future firmware package not function and fail to properly start the Tmedia unit, the last known good boot directory will be used instead.

5.2 Removing a Firmware Package

A firmware package is approximately 18 MB in size. The flash memory of a Tmedia unit is 125 MB. Before you exceed the flash memory limit, it is recommended that you remove any unused firmware packages from the flash memory.

To remove a firmware package from the local file system:

1. Start the install tool located in the /tb/bin/release/<proc-OS-arch>/ directory.
2. Select option 21: remove a package.
3. Enter the number associated with the package to remove.

5.3 Installing a New License

To install a new license:

1. Start the installation tool located in the /tb/bin/release/<proc-OS-arch>/ directory.
2. Select option 22: Install a license.

When you are asked for the path of the license file, enter the path in which you saved the license file (XX_TB000XXX_RELEASE_VX_XX_RCX_license.dat) received from the TelcoBridges support group.

It is important that you use the license file that has the same version as the package installed on the Tmedia unit. You must know the serial number of the TelcoBridges Tmedia unit to be able to choose the right license. For example, the license file WD_TB000103_RELEASE_V2_4_5_RC1_license.dat would be valid for any Tmedia unit with the serial number TB000103 and any release v2.4 package.

3. Select option **99** to restart the TelcoBridges Tmedia unit and apply the new license.

Note The license installed can be verified by using option 34 or option 2 of the installation program.

The installed license can be verified only if the firmware loaded is the same as the running firmware (same versions). This can be verified using option 10.

To verify a license on another firmware, set the next boot directory (option 12) and restart the Tmedia unit.

When a license expires, the Tmedia unit restarts by itself and no features will be available until a new license is installed.

Some licenses can be upgraded live without restarting the TelcoBridges Tmedia unit, others cannot.

Do not restart the TelcoBridges Tmedia unit if:

- The license's expiry time is extended or becomes permanent. For example, the expiry date is September and there is an extension until November.
- The license adds features to an existing feature. For example, there are 120 IVR features activated, and the new license provides 240 voice processing resources.

Restart the TelcoBridges Tmedia unit if:

- The old license has expired and an extended or permanent license has been installed.
- A new feature has been added. For example, adding additional physical interfaces is in the new license, however, it is not in the old license.

Chapter 6 Troubleshooting Tools

This chapter provides guidance in what actions to take when encountering system problems prior to contacting TelcoBridges Customer Support.

The following topics are covered:

- Reporting a Problem
- Preparing your setup information
- tblogtrace or Udplisten Log
- TbDebug Dump Files
- Backdoor Tools
- tbsigtrace signaling traces
- General Debugging Tips

6.1 Reporting a Problem

TelcoBridges has developed extensive tools to gather information about a Tmedia system to solve problems quickly. Users **MUST** gather all related logs before reporting a problem to TelcoBridges Support via Email or MSN. Various logging methods are described in the following sections.

Once information is gathered and sent to the TelcoBridges Support group (support@telcobridges.com), the Support group will assign a tracking number to the problem. All follow-up correspondence, whether it be by E-mail, MSN, or phone call must refer to the tracking number which the problem has been assigned.

6.2 Setup Information

The setup information must include:

- Physical connections. If necessary, describe it in a network diagram.
- Specify if your product is a TMP6400, or a TMS1600.
- Host controlling the TMP6400s (manufacturer, CPU type, memory, OS version and patch level, Ethernet interface details)
- Telecommunication connectivity diagram (for example: E1/T1/J1, DS3, STM-1/OC-3, VoIP Ethernet switch, etc)
- Application description
- Remote access to system (SSH, VPN, VNC, Remote desktop, etc.)
- For a signaling-related problem, specify which side is initiating the call

6.3 tblogtrace (Mandatory)

tblogtrace is started automatically by Toolpack.

Useful information about this application is listed as follows:

- tblogtrace captures events from the system at run-time.
- The TMP6400s and TMS 1600s transmit their system messages as UDP ASCII packets.
- The tblogtrace **MUST** be setup to gather information at all times, when developing the application and also in a live system. In this way, Telcobridges can identify a problem even if it occurred in the past.

The Toolpack system starts and configures the tblogtrace application automatically. The files can be found in the `[InstallDir]/toolpack/setup/SystemId/MajorVersion/apps/tblogtrace/` directory.

If you are not using Toolpack, start it manually, as follows:

1. Locate the tblogtrace application located in `tb/apps/tblogtrace/release/<proc-OS-arch>/` directory.

tblogtrace requires that certain parameters are specified:

Usage : `tblogtrace -port <Port> -gw <System Id> -adapter <Adapter name>`

For example: `tblogtrace -port 52492 -gw 12358 -adapter TB002492`

When verifying the tblogtrace log, errors or failures are usually shown in RED in the console or for lines displaying 'E '. Either of these two conditions should be reported to TelcoBridges.

6.4 Tbdebug Dump Files (Mandatory)

The tbdebug copies information about TelcoBridges libraries and TMP6400s into log files. This includes software, the release running on the host, the firmware release running on the TMP6400, TMP6400 information, available features, configuration, and status information.

The tbdebug files must be sent when a problem is reported. If the problem is reproducible, the tb6ebug dump files are verified before and after the problem is reproduced. This will aid in identifying the problem quickly.

For further information about Tbdebug, refer to TelecoBridges TB Wiki at:

http://docs.telcobridges.com/mediawiki/index.php/Toolpack_Debug_Application:Tbdebug

6.5 Backdoor Tools

A number of backdoor tools are available as follows:

- `tbx_cli_tools_remote`
- `tbshows`
- VoIP Traffic Capture
- Wireshark
- `tstreamlisten`
- Stream server audio packets to wave file
- `tbsigtrace`

6.5.1 `tbx_cli_tools_remote`

The `tbx_cli_tools_remote` tool can be used to get the text-based GUI control of TB applications like `Toolpack_Engine`, `Toolpack_sys_manager`, `tstreamserver`, and others which are run in background.

For further information about `tbx_cli_tools`, refer to TelecoBridges TB Wiki at:

http://docs.telcobridges.com/mediawiki/index.php/Toolpack_Debug_Application:tbx_cli_tools_remote

6.5.2 Line/Trunk Status (Tbshows)

```
tbshows (/tb/bin/release/[OS version]/)
```

tbshows can be used to show trunk alarm and performance counters. The tool will check the trunk status periodically to show the most updated trunk status. Users can use the up/down/left/right arrow keys to show the performance data on different trunks. Use a-s-d-x to scroll and view other lines services.

Options 'G' and 'S' enable you to get and set the trunk interface parameters.

Option 'R' can be used to reset the performance counter value to zero.

It is also possible to allocate all line interfaces in different configurations. This is useful for DS3 and OC3/STM-1 configurations, in order to help users understand the configuration.

6.5.3 VoIP Traffic Capture

When troubleshooting VoIP related issues, a direct Ethernet connection can be established between the host's Gigabit Ethernet interface and the VoIP1 interface on the TMP6400. Wireshark is connected on the Gigabit Ethernet interface on the host server.

To capture VoIP Traffic, do the following:

1. Connect VoIP1 interface to Ethernet port of a server
2. Telnet to TMP6400
3. Type this command:

```
mv88eMonitor 0x4 0x4 3 (Copies everything from VoIP0 to VoIP1) *
```

4. Start pcap capture on the server Ethernet port (either wireshark or tcpdump)
5. To stop the tracing:

```
mv88eMonitor 0 0 3
```

6.5.4 Wireshark (formerly called Ethereal)

Wireshark is useful for capturing both VoIP traffic as well as Streamserver packets (play/record function).

This program is available at this site: www.wireshark.org

6.5.5 Tbstreamlisten

```
tb\apps\tbstreamlisten\release\[OS version]
```

This allows the recording of the raw data from a TDM stream. Please ask customer support for instructions regarding this function.

6.5.6 Stream Server Audio Packets to Wave File

It is possible to capture all audio packets transmitted to and from the Stream Server and to convert them into wave files for analysis. You can use Wireshark or tcpdump on the server running the tstreamserver application.

The conversion tool, streamserver_pkt_to_wav can be found at the following location:

/tb/bin/release/[OS version].

6.5.7 tbsigtrace Signaling Traces

The tbsigtrace program is a tool used to capture SS7, ISDN, and SIP signaling.

Note This application can be started with Toolpack. For further information, refer to the TelcoBridges TB Wiki at:
http://docs.telcobridges.com/mediawiki/index.php/Toolpack_Debug_Application:Tbsigtrace

6.6 General Debugging Tips

Logs are important because they enable us to find out about the exact environment in order to repeat the problem.

Network configuration is important because it tells us:

- If the host applications (or TB applications) are running on a host having more than 2 Ethernet interfaces or having more than 1 IP address on the same Ethernet interface. The `TBX_GW_ADDRESS_0` and `TBX_GW_ADDRESS_1` must be set to match with the subnet used for `ETH0` and `ETH1` of the TB hardware products.

If you need run separate systems running on the same network, the communication port `system_ID` used on the Tmedia units and the application can be changed.

To set the `system_ID` on the Tmedia units, do the following:

- Telnet to the hardware and do `set_boot` command. Change the `system_ID` through the gateway port parameter.

The default value is 12358.

To set the `system_ID` for the pre-compiled TB applications:

- Set the `system_ID` through `TBX_GW_PORT` in the `config.txt` file of the TB applications. If zero is used, the application will look for the environment variable `TBX_GW_PORT` for the `System_ID` value. If the variable is missing, the default `System_ID` value 12358 will be used.

To set the `system_ID` for user application:

- Set the `un32GwPort` parameter in the TBX library parameters. If zero is used, the application will look for the environment variable `TBX_GW_PORT` for the `System_ID` value. If the variable is missing, the default `System_ID` value 12358 will be used.

Note `system_ID` is also referred to as `tbx_gw_port` and gateway port.
