

**Tmedia**

**System Installation Guide for  
TMG3200**

9010-00179-1A, Issue 2.2



The information in this document is subject to change without notice. No part of this document may be reproduced or transmitted in any form or by any means, electronic or mechanical, for any purpose, without the express written permission of **TelcoBridges**. **TelcoBridges** may have patents or pending patent applications, trademarks, copyrights, or other intellectual property rights covering subject matter in this document. The furnishing of this document does not give you license to these patents, trademarks, copyrights, or other intellectual property except as expressly provided in any written license agreement from TelcoBridges.

The information provided in this document is intended as a guide only. For the latest detailed engineering specifications, please contact **TelcoBridges** Customer Support. **TelcoBridges** is committed to continually improving product designs; as a result, product specifications may be subject to change without notification.

© 2003-2009 **TelcoBridges**. All rights reserved.

TelcoBridges, Tmedia, TMP6400, TMG3200, TMP800, TMG800, TMS1600 Switch, Toolpack API, On a Blade, System-Blade, TB-1+1 Solution, TB-16-E1/T1/J1, TB640-DS3, TB640-E1/T1/J1, TB640-OC3/STM-1, TB-8-E1/T1/J1, TB-IVR Mezzanine, TB-Multi-Blade, TB-Multi-Blade Mezzanine, TB-N+1-15 Solution, TB-N+1-3 Solution, TB-StreamServer, TB-Video, TB-VoIP Mezzanine, TM-1000 Network Probe are trademarks of **TelcoBridges** Inc. All rights reserved 2009. All other trademarks are property of their owners. This information is subject to change without notice.

Document Title: Tmedia System Installation Guide for TMG3200  
Document Number: 9010-00179-1A, Issue 2.2, 2010-10-17//01:50

## HEAD OFFICE

91 rue de la Barre, Suite 01  
Boucherville, Quebec  
J4B 2X6, Canada

T +1 450 655 8993

F +1 450 655 9511

[info@telcobridges.com](mailto:info@telcobridges.com)

[support@telcobridges.com](mailto:support@telcobridges.com)

# Preface

## About this Guide

This guide describes the installation and setup of the Tmedia TMG3200 telecom platform and its connections to voice, and IP networks.

## Conventions

Terminology	Description
Tmedia Management Interface	This is the interface used to configure and manage the TMG3200.

## Contact Us

If you have comments about this guide or any other TelcoBridges technical documentation, please send an E-mail to [support@telcobridges.com](mailto:support@telcobridges.com).



# Table of Contents

Chapter 1	Introduction .....	1
	1.1 Installation Overview .....	2
	1.2 Installation Prerequisites .....	3
	1.3 Preventing Electrostatic Discharge Damage.....	3
	1.4 Recommended Reading .....	4
Chapter 2	Equipment Connections .....	5
	2.1 Package Contents.....	6
	2.1.1 TMG3200 Package Contents.....	6
	2.2 Rack mounting the TMG3200 .....	7
	2.2.1 Prerequisites .....	7
	2.2.2 Vertical Placement of TMG3200 .....	7
	2.2.3 Mounting the TMG3200 .....	8
	2.3 Connecting to the Tmedia Management Interface .....	9
	2.3.1 Prerequisites .....	9
	2.3.2 Interconnections .....	9
	2.4 Connecting to the VoIP Network .....	10
	2.4.1 Prerequisites .....	10
	2.4.2 Interconnections .....	11
	2.5 Connecting to the PSTN .....	12
	2.5.1 Prerequisites .....	12
	2.5.2 RJ48 Type Interface (T1/E1/J1) .....	13
	2.5.3 SCSI Interface (T1/E1/J1) .....	15
	2.5.4 Dual BNC Interface (DS3).....	17
	2.5.5 Optical Interface (OC3/STM-1).....	18
	2.6 Powering Up.....	19
	2.6.1 Prerequisites .....	19
	2.6.2 Connecting to AC Power.....	19
	2.6.3 Connecting to DC Power.....	21
	2.6.4 Verifying the LED Status Indications.....	23
	2.7 Powering Down .....	24
Chapter 3	Initial System Configuration .....	25
	3.1 Configuring the TMG3200.....	26
	3.2 Setting the Time Zone.....	27
	3.3 Configuring the Toolpack System Using the Web Portal .....	27
	3.4 Changing the TMG3200 Host IP .....	28
	3.5 Changing VoIP Interface Addresses .....	28
	3.6 Changing Passwords .....	28
Chapter 4	System Upgrades.....	29
	4.1 Installing a New License .....	29

Chapter 5	Troubleshooting Tools.....	31
5.1	Connecting to the Serial Port of the TMG3200 .....	32
5.2	Configuring the Terminal Emulator Application .....	34
5.3	Reporting a Problem .....	35
5.4	Setup Information .....	35
5.5	Tbdebug Dump Files (Mandatory).....	35
5.6	Application Logs .....	35
5.7	Backdoor Tools .....	36
5.7.1	tbx_cli_tools_remote .....	36
5.7.2	Line/Trunk Status (Tbshowls).....	37
5.7.3	VoIP Traffic Capture.....	37
5.7.4	Wireshark (formerly called Ethereal).....	37
5.7.5	Tbstreamlisten.....	38
5.7.6	Stream Server Audio Packets to Wave File .....	38
5.7.7	tbsigtrace Signaling Traces .....	38

# Chapter 1 Introduction

This chapter provides an introduction to the installation and setup of a Tmedia system using the TMG3200.

The following topics are covered:

- Installation overview
- Installation prerequisites
- Other recommended reading

## 1.1 Installation Overview

The installation and setup of a TMG3200 unit, as shown in figure 1.1 on page 2, is described by a series of chapters dealing with installation tasks in the following order:

- Rack mounting the TMG3200
- Connecting to the Tmedia Management Interface
- Connecting to the VoIP network
- Connecting to the PSTN
- Powering Up
- Initial System Configuration
- System Upgrades
- Troubleshooting

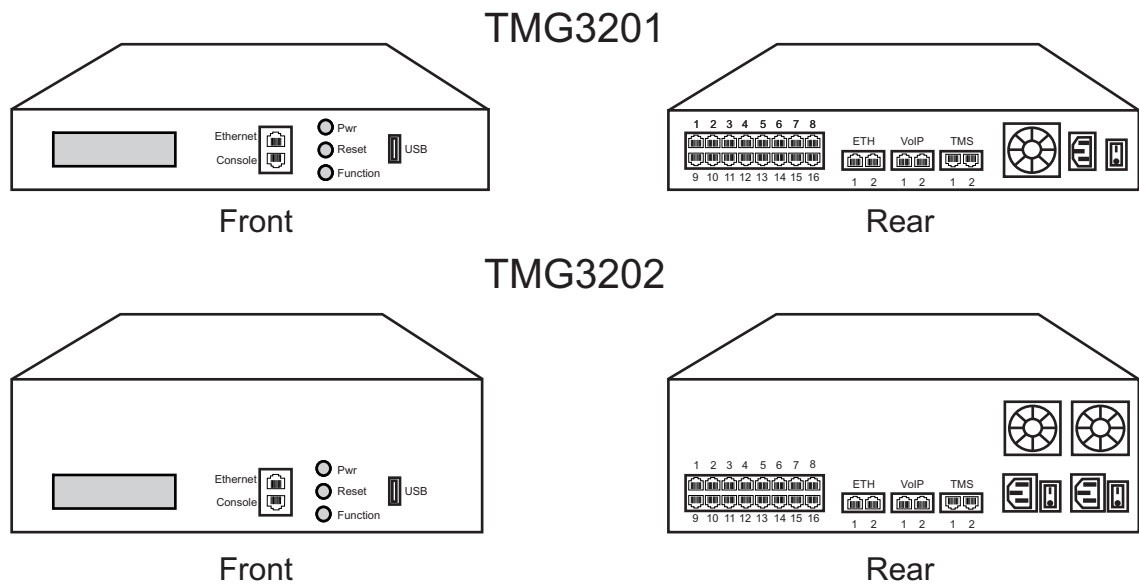

Figure 1.1 TMG3201, TMG3202, seen from front and rear.



---

## 1.2 Installation Prerequisites

For the TMG3200 system installation to proceed without interruption, it is important that you verify that you have on hand all of the necessary materials. Prior to beginning the installation, you should have prepared for the following:

- Adequate space for the installation of your TMG3200. Consider that you will need to mount the TMG3200 on a 19" customer-provided equipment rack.
- Adequate power supply and power connections. To guarantee an uninterrupted supply, the TMG3200 must be powered by a dedicated power source. Consider that the TMG3200 will require one to two power connections. TMG3200s (other than 2U DC-powered units) are not shipped with power cords; therefore, you will need to plan for your power cable requirements.
- To run your telecom applications on the TMG3200, you will need to have purchased an adequate number of licenses for the features that you will use.

## 1.3 Preventing Electrostatic Discharge Damage

Electrostatic discharge (ESD) can damage equipment and impair electrical circuitry. It may occur if electronic printed circuit cards are improperly handled and may cause complete or intermittent failure.

---

**Attention** Always follow ESD prevention procedures when removing and replacing modules:

- Ensure that the TelcoBridges TMG3200 is electrically connected to earth ground.
  - Wear an ESD-preventive wrist strap and ensure that it makes good contact with your skin. Connect the wrist strap clip to an unpainted surface of the TMG3200 or the grounded equipment rack in order to channel away all ESD voltage safely to ground. To guard against ESD damage and shocks, the wrist strap and cord must be in proper working condition.
  - If no wrist strap is available, and you must work with the TMG3200, ground yourself by touching a metal part of the chassis.
-

## 1.4 Recommended Reading

This document assumes that you are well versed in the installation of the TelcoBridges TMG3200 and have been trained to work with the equipment. If you have any technical questions, please contact TelcoBridges technical support or send an E-mail to [support@telcobridges.com](mailto:support@telcobridges.com).

Other documents exploring various aspects of the Tmedia system are available on the TelcoBridges TB Wiki at: [http://docs.telcobridges.com/mediawiki/index.php/Main\\_Page](http://docs.telcobridges.com/mediawiki/index.php/Main_Page)

# Chapter 2      Equipment Connections

This chapter provides the connection procedures for the TMG3200 as follows:

- Rack mounting the TMG3200
- Connecting to the Tmedia management interface
- Connecting to a PSTN Network
- Connecting to an IP network
- Connecting Power
- Verifying LED Status

## 2.1 Package Contents

You will have received one TMG3200. The TMG3200 is the telecom platform on which you will run your telecom applications.

### 2.1.1 TMG3200 Package Contents

In the TMG3200 box, you will find:

- One TMG3200
- One set of mounting brackets with screws. These are used for the mounting of a TMG3200 on a 19" rack.
- One DB-9 to RJ-45 adapter. Allows you to interface the serial port of your computer with the RJ-45 console port of the TMG3200.
- SCSI cables and patch panels. This is optional and only provided if the PSTN interface on your TMG3200 features SCSI connectors.
- Three CAT5 Ethernet straight cables (male-male), three meters in length.
- One warranty sheet
- One packing slip
- One TMG3200 Quick Installation guide (a 1-page sheet that provides a pictorial view of equipment setup).
- For 2U DC units, two DC power cables are provided.

Not included with the TMG3200:

- No power cords are supplied for the AC units. Only in the case of the 2U DC unit with redundant DC supplies, are two power cables supplied.
- A 19" equipment rack. You will use a standard 19" wide equipment rack to install the TMG3200.

## 2.2 Rack mounting the TMG3200

The TMG3200 is mounted on a customer provided equipment rack using the mounting hardware packaged in the box.

### 2.2.1 Prerequisites

To rack mount the TMG3200, you will need:

- One 19" customer provided equipment racks. The rack must be solidly anchored to the floor with appropriate support at the top of the racks.
- Climate controlled room: 0 to +50 Celsius, 0 to 95% non-condensing humidity.

### 2.2.2 Vertical Placement of TMG3200

The TMG3200s are housed in either a 1U or 2 U chassis, as tabulated in table 2.1 on page 7. It is important that you provide for enough room on the equipment rack to allow for the installation of the TMG3200. Consider the available space on your equipment rack and the height of the TMG3200. Due to the rear-exhaust heat vents and the efficient heat dissipation design, there is no need to leave any physical vertical space above or below the placement of the TMG3200 on the equipment rack.

Table 2.1 TMG3200 Physical Height

Tmedia Model Number	Vertical Height
TMG3201	1U
TMG3202	2U
Patch Panels <sup>a</sup>	1U

a. TMG3200s configured with a 32 to 64 T1/E1 TDM module require one patch panel for each 32 E1/T1 line grouping.

## 2.2.3 Mounting the TMG3200

The TMG3200 is mounted on the 19" equipment rack using the angle brackets and screws provided in the box. To mount the hardware, proceed as follows:

**To mount the TMG3200 proceed as follows:**

1. Using two metal screws, attach one angle bracket to the front, left-hand side of the TMG3200 when viewed from the front, as shown in figure 2.1 on page 8. Repeat the same for the angle bracket on the right-hand side.
2. Start mounting equipment at the top-most position of the rack, keeping in mind the space required on the equipment rack as described in Section 2.2.2 "Vertical Placement of TMG3200" on page 7.

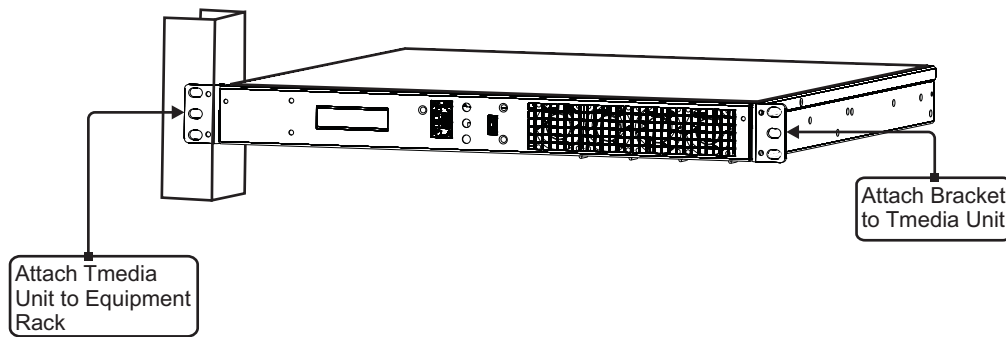

Figure 2.1 Mounting the TMG3200

## 2.3 Connecting to the Tmedia Management Interface

The Tmedia Management Interface enables administrators to perform management tasks on the TMG3200.

### 2.3.1 Prerequisites

To communicate with the Tmedia Management Interface for a TMG3200, the following is needed:

- One CAT5 Ethernet cable with RJ45 male-male terminations.

### 2.3.2 Interconnections

The TMG3200 provides a Tmedia Management Interface, using one Gigabit Ethernet network link, as shown in figure 2.2 on page 9.

**To communicate with the Tmedia Management Interface:**

1. Connect the supplied CAT5 Ethernet cable to the port labelled “Ethernet” at the front of the TMG3200.

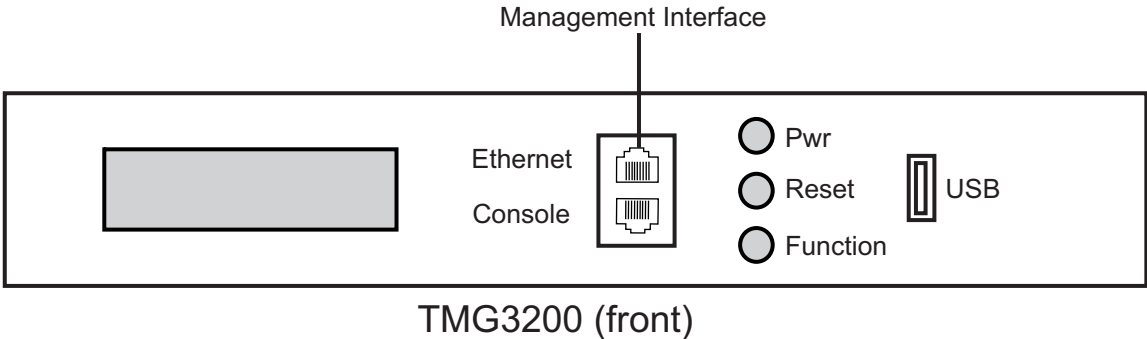

Figure 2.2 Tmedia Management Interface

## 2.4 Connecting to the VoIP Network

The TMG3200 features dual 100 Mbps/1000 Mbps ports for connection to different VoIP networks. Should one of the IP networks fail, the TMG3200 will continue to handle VoIP traffic using the alternate network.

---

**Note:** **Certain configurations of the TMG3200 will exceed 100 Mbps, therefore 1000 Mbps is recommended.**

---

### 2.4.1 Prerequisites

To connect the TMG3200 to the VoIP network, you will need:

- Gigabit Ethernet switch. A second one is required to support redundancy of the VoIP interface.
- One CAT5 Ethernet cable with RJ45 male-male terminations for each TMG3200.
- If your system has access to a second VoIP network, you can connect it to a second VoIP interface of the TMG3200 with an RJ45 (male-male) CAT5 Ethernet cable.



### 2.4.2 Interconnections

The TMG3200 is connected to the VoIP network by one or optionally two Ethernet GigE network links, as shown in figure 2.3 on page 11.

**To connect the TMG3200 to the VoIP network:**

- 1. Connect a CAT5 Ethernet cable to VoIP1 at the rear of the TMG3200. Connect the other end of the same CAT5 cable to the Gigabit Ethernet switch.
- 2. If your system employs a second Gigabit Ethernet switch for redundancy, connect a second CAT5 Ethernet cable to VoIP2 at the rear of the TMG3200. Connect the other end of the same CAT5 cable to the second Gigabit Ethernet switch.

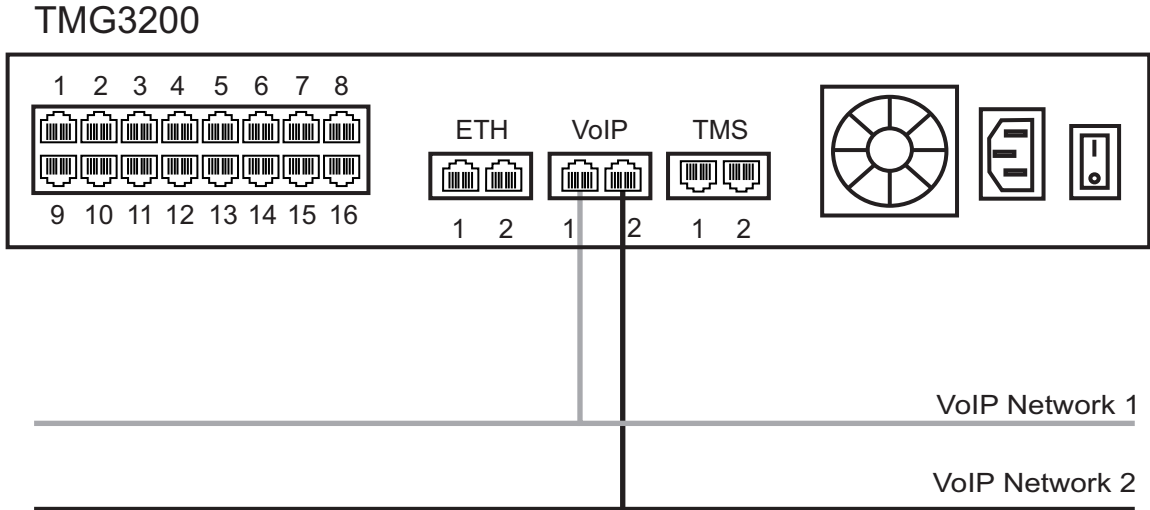

Figure 2.3 Connecting to the VoIP Network

## 2.5 Connecting to the PSTN

The TMG3200 features a variety of interfaces to the PSTN network. Each TMG3200 that makes connection with the PSTN will feature a PSTN interface.

### 2.5.1 Prerequisites

To connect the TMG3200 to the PSTN network, you must comply with one of the following:

- Your TMG3200 features 16 modular 8-conductor RJ48 type jacks for connection to T1/E1/J1 lines. You will need one cable for each (T1/E1/J1) interface on the TMG3200. If you are making your own cables, refer to figure 2.5 on page 14 for crossover or straight cable wiring connections.
- Your TMG3200 features SCSI connectors for connection to T1/E1/J1 lines. You will require one patch panel for each 32 line grouping of T1/E1/J1 line interfaces on the TMG3200.
- Your TMG3200 features BNC connectors for connection to DS3 lines. You will require two coaxial cables for each DS3 interface.
- Your TMG3200 features electrical or optical STM 1 connectors. You will require two fibre optic cables for the STM 1 interface of the TMG3200.

## 2.5.2 RJ48 Type Interface (T1/E1/J1)

A TMG3200 with 16 RJ48 type ports enables the connection to T1/E1/J1 lines. The termination impedance is set at 100 ohms for T1 lines and 120 ohms for E1 lines. It is possible to connect an external balun in order to convert to 75 ohms. See figure 2.4 on page 13. If you are making your own cables, refer to figure 2.5 on page 14 for crossover or straight cable wiring connections.

---

**Note** All ports may not be active. T1/E1/J1 ports are activated by software license; the number of active ports depends on the licenses purchased.

---

**To connect the TMG3200 (RJ48 type) to the PSTN:**

1. Start with port 1 located at the top and left-most position. Connect one cable between this port and the T1/E1/J1 line (figure 2.4 on page 13).
2. Repeat step 1, using the next available port.

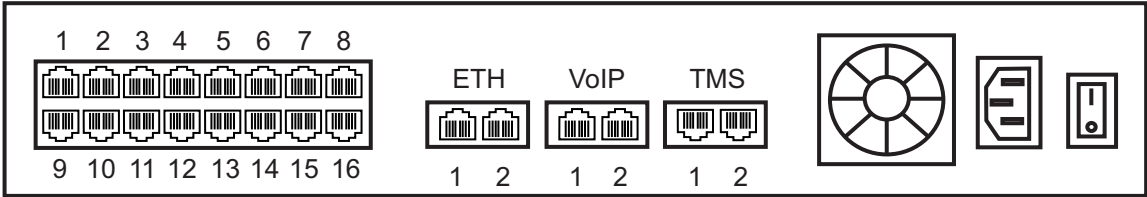
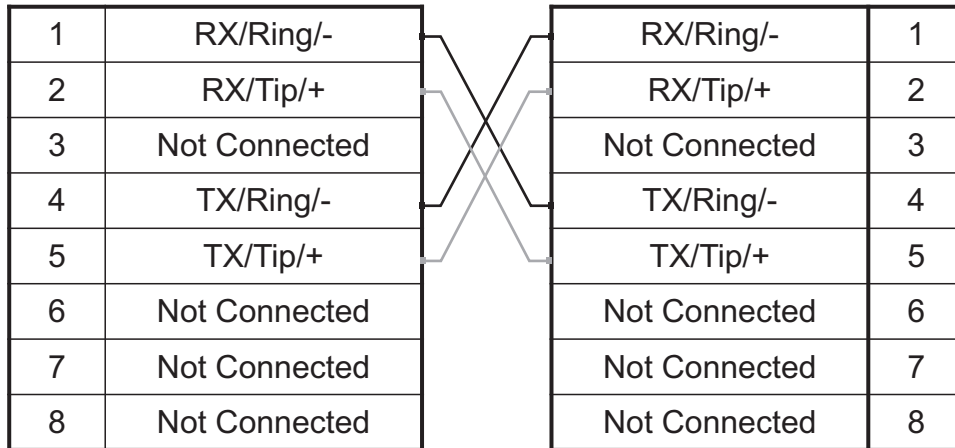

Figure 2.4 16-Port Interface to the PSTN

**RJ 48 (T1/E1/J1) Wiring Schematic: Crossover Cable**



**RJ 48 (T1/E1/J1) Wiring Schematic: Straight Cable**

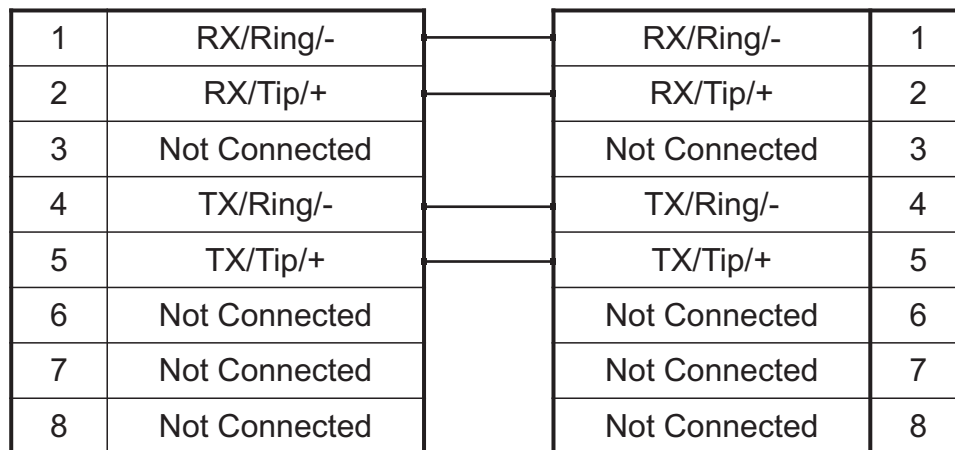

Figure 2.5 RJ48 Wiring Schematic

### 2.5.3 SCSI Interface (T1/E1/J1)

A TMG3200 with 4 SCSI connectors enables the connection to T1/E1/J1 lines. The termination impedance is set at 120 ohms. It is possible to connect an external balun in order to convert to 75 ohms. See figure 2.6 on page 16

---

**Note** All ports may not be active. T1/E1/J1 ports are activated by software license; the number of active ports depends on the licenses purchased.

---

#### To connect the TMG3200 (SCSI) to the PSTN:

1. Start with the SCSI ports 1-16 located at the bottom right as shown in figure 2.6 on page 16. Connect one SCSI cable between this port and SCSI patch panel number 1, ports 1-16. Connect SCSI ports 17-32 to patch panel number 1, ports 17-32.
2. Repeat step 1, using lines 33-64 and a second patch panel. Connect lines 33-48 to patch panel 2, port 1-16. Connect lines 49-64 to patch panel 2, ports 17-32.

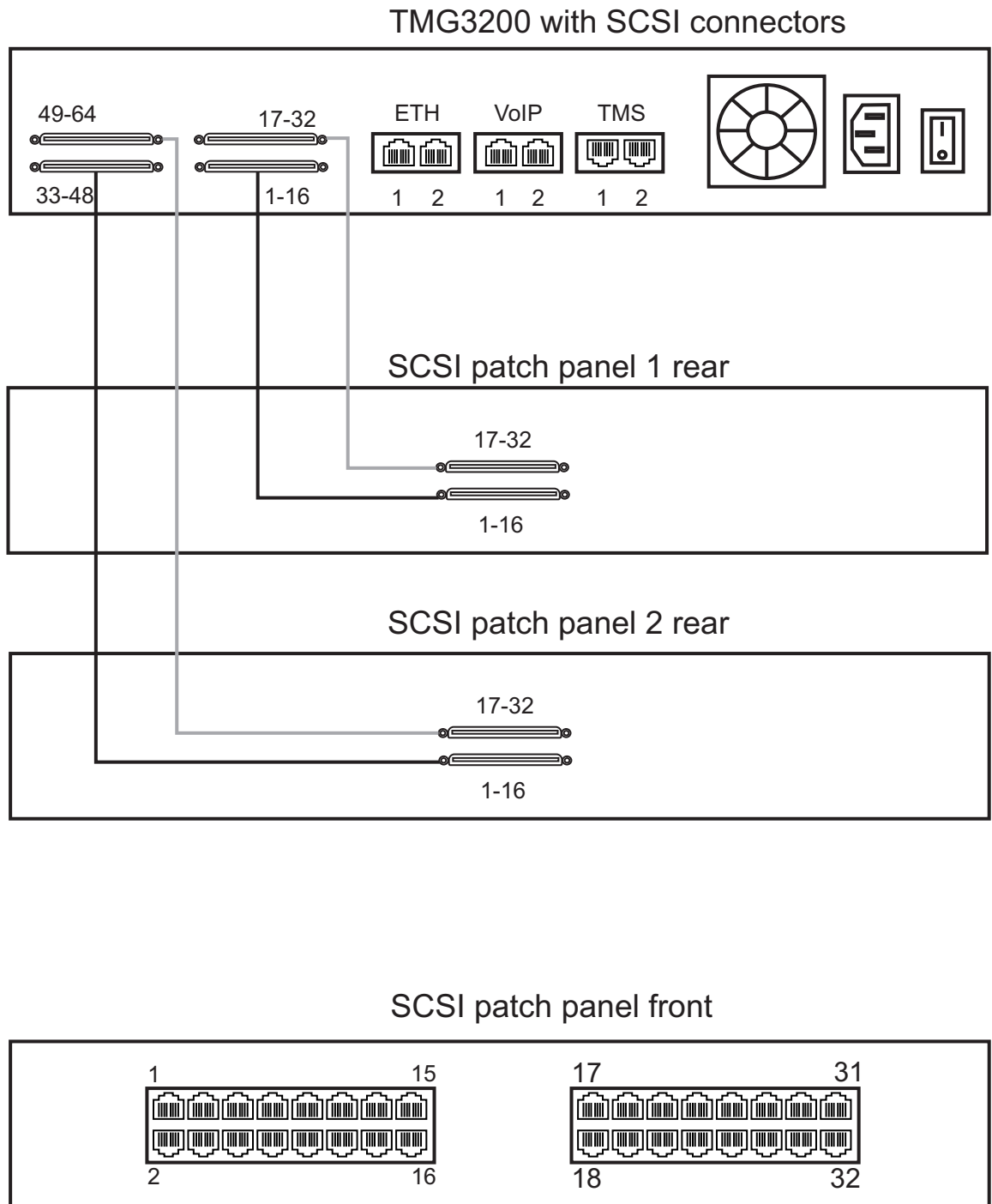

Figure 2.6 SCSI Interface to the PSTN

### 2.5.4 Dual BNC Interface (DS3)

A TMG3200 with 3 sets of BNC connectors enables the connection to DS3 lines. See figure 2.7 on page 17

**Note** All ports may not be active. DS3 ports are activated by software license; the number of active ports depends on the licenses purchased.

**To connect the TMG3200 (DS3) to the PSTN:**

1. Start with the Dual BNC port pair #1 (right-most) as shown in figure 2.7 on page 17. Connect one pair of BNC cables between this port and the DS3 line.
2. Repeat step 1, using the next available pair of BNC PSTN interface ports.

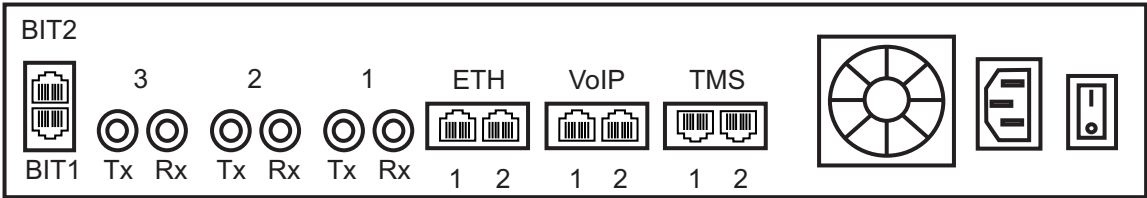

Figure 2.7 DS3 Interface to the PSTN

## 2.5.5 Optical Interface (OC3/STM-1)

A TMG3200, with one main and one backup OC3 or STM-1 port enables connection to OC3/STM-1 lines. See figure 2.8 on page 18. Refer to table 2.2 on page 18 for a listing of optical interfaces. The default OC3/STM-1 connection is SMF, intermediate reach, (SFP-OC3-IR1) 1310 nm with LC type connectors.

---

**Note** Please make certain that the correct model is selected at the time of ordering. If your installation requires a different model from the one that has been provided, you must replace it.

---

### Automatic Protection Switching

The APS port is used for OC3/STM-1 redundancy. Switchover occurs automatically based on configurable parameters. It is recommended that APS be used if the installation provides this feature.

#### To connect the TMG3200 (Optical Interface) to the PSTN:

1. Connect a fiber optic cable between the Main port and OC3/STM-1 line, as shown in figure 2.8 on page 18.
2. Connect a fiber optic cable between the APS port and OC3/STM-1 line.

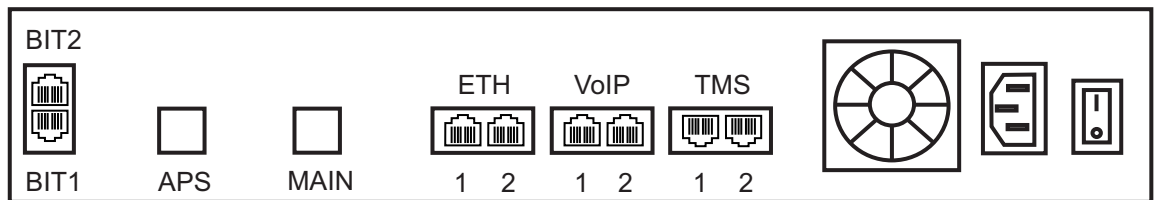

Figure 2.8 Optical Interface to the PSTN

Table 2.2 Optical Interfaces

Transceiver Model	Description	Spec	Mode	Type	Range (Km.)	Wavelength (NM)	Connection
SFP-OC3-IR1	OC3/STM1	Hot Pluggable	Single-mode	Intermediate reach	15	1310	LC
SFP-STM1E	STM1E (Electrical)	Hot Pluggable	75 ohms Cooper	Max 180m	<sup>a</sup>	NA	DIN (mini-coax)

a. Variable range



## 2.6 Powering Up

The TMG3200 is furnished with one or optionally two AC or DC power connections. Only once all other equipment installation work has been completed should the TMG3200 be powered up.

### 2.6.1 Prerequisites

To power the TMG3200, you will need:

- A power source.
- One power cable for the TMG3200. Optionally a second power cable is required if the TMG3200 is furnished with a secondary power supply.

### 2.6.2 Connecting to AC Power

The TMG3200 is furnished with one or optionally two AC power connectors.

**To connect the TMG3200 to AC Power:**

1. Connect one AC power cable between the AC connector of the TMG3200 and an AC supply. See figure 2.9 on page 20. If the TMG3200 features a second AC connector, connect an additional AC power cable between this connector and an AC power supply. If the TMG3200 features a second power supply and it is not connected to an AC power source, press the green button located at the rear of the unit to disable the audible alarm. See figure 2.9 on page 20.
2. Power up the TMG3200 by turning on its AC power switch(es).

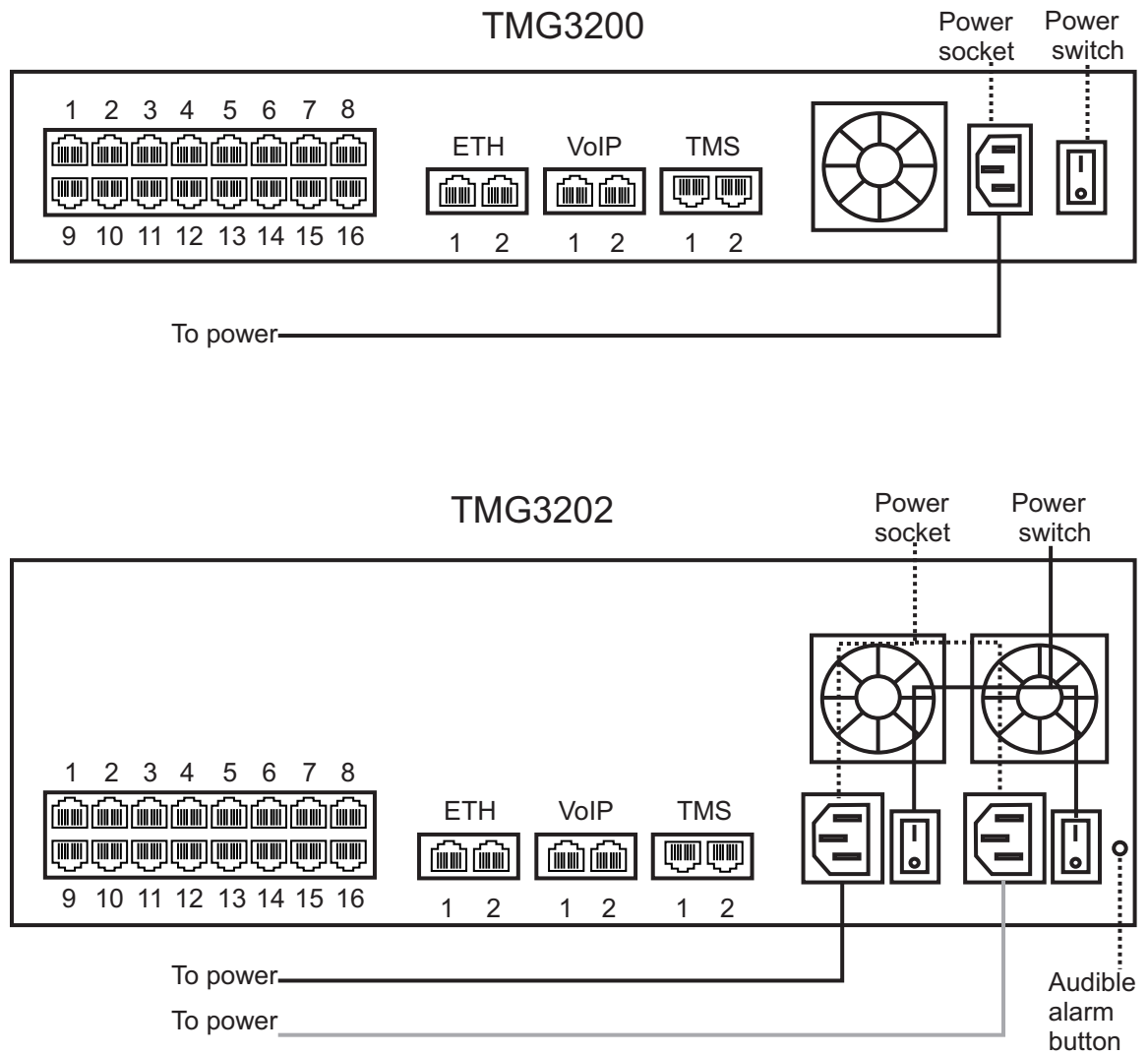

Figure 2.9 AC Power Connection

### 2.6.3 Connecting to DC Power

The TMG3200 DC models are furnished with one or optionally two DC power connection ports. In addition, each DC powered TMG3202 is supplied with a pair of DC power cables. The connection of DC power is described for:

- TMG3201
- TMG3202

**To connect the TMG3201 to DC power:**

1. Connect a ground wire to the ground lug located at the rear of the TMG3201, as shown in figure 2.10 on page 21.
2. Connect a 14 AWG wire between the positive terminal of a DC power source and the terminal on the TMG3201 labelled as  $\overline{+}$ .
3. Connect a 14 AWG wire between the negative terminal of a DC power source and the terminal on the TMG3201 labelled as 48V.

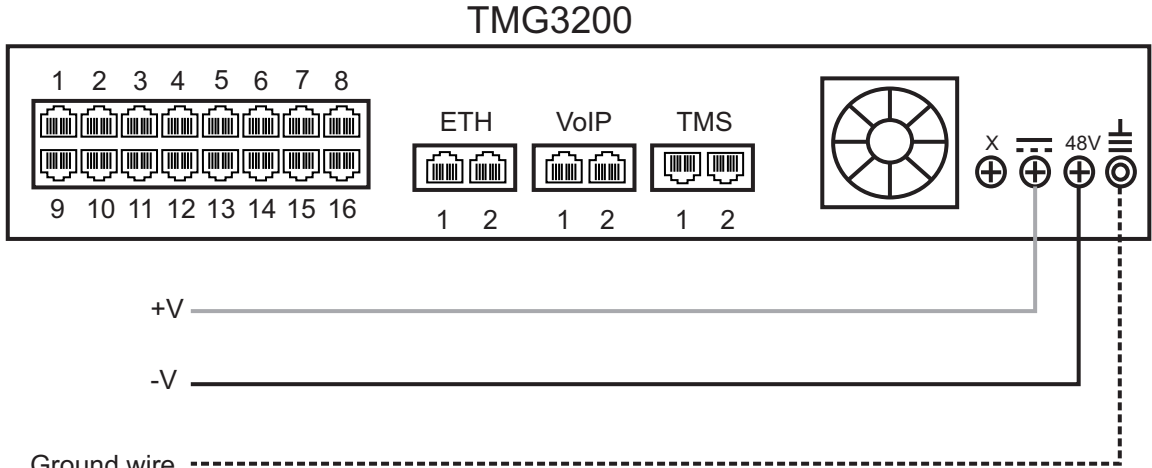

Figure 2.10 TMG3201 DC wiring diagram

**To connect the TMG3202 to DC power:**

1. Connect the DC cable supplied with the TMG3202, as shown in figure 2.11 on page 22, to the DC outlet at the rear of the TMG3202.
2. Connect the red lead of the DC power cable to the positive terminal of the DC power source, as shown in figure 2.11 on page 22.
3. Connect the black lead of the DC power cable to the negative side of the DC power source.
4. Repeat steps 1-3 for the second power DC power source.

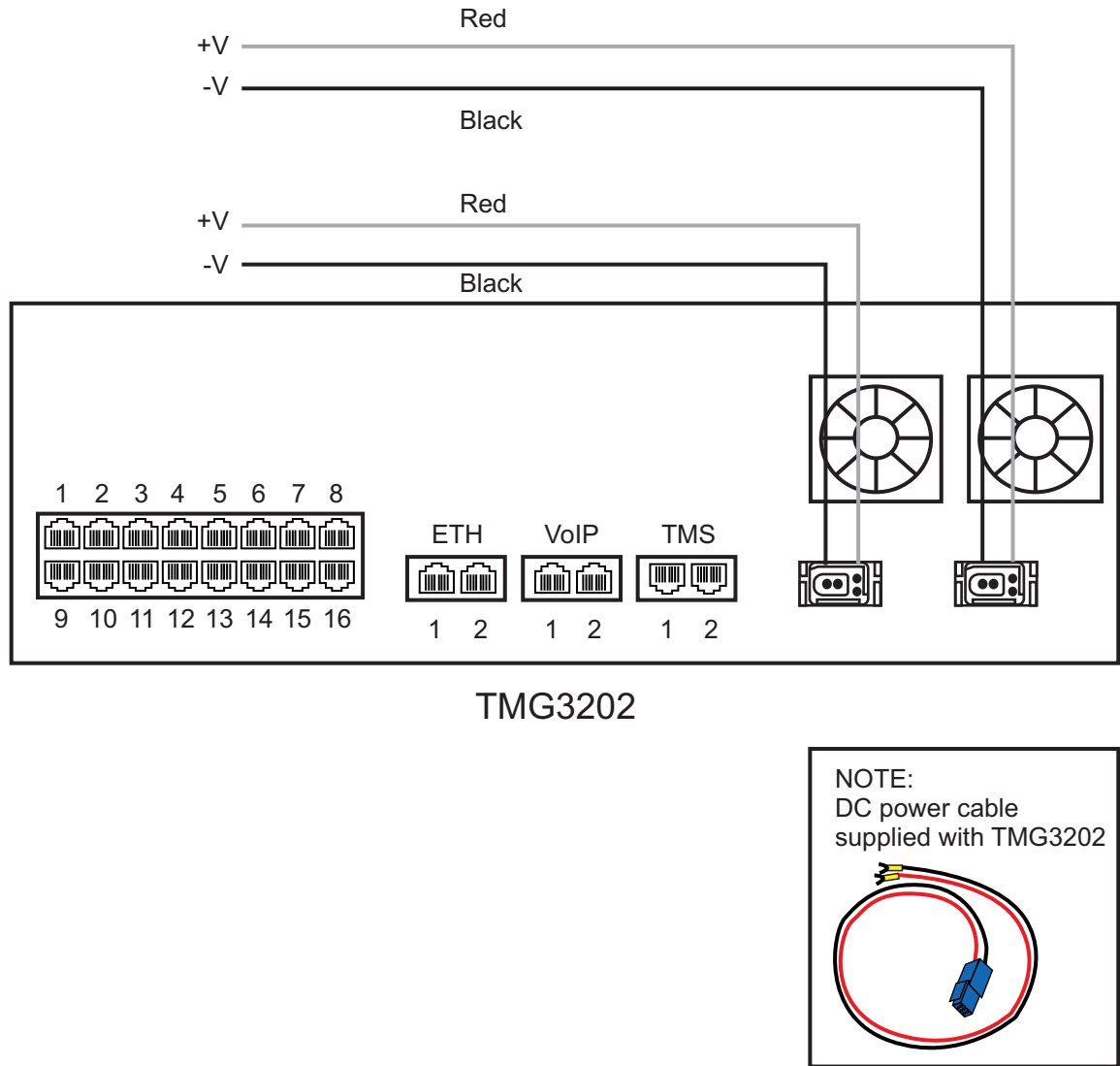

Figure 2.11 TMG3202 DC wiring diagram

## 2.6.4 Verifying the LED Status Indications

When the TMG3200 has been powered, verify the front panel of the unit to determine that all indications are normal.

Once the TMG3200 has run successfully through its system boot procedures, the following will be displayed in an alternating fashion as described in table 2.3 on page 23:

Table 2.3 TMG3200 Displays

Display Order	Display
First Screen	IP 0: <ip address of eth0. E.g. 192.168.0.2> IP 1: <ip address of eth1 E.g. 192.168.0.3>
Second Screen	<board type.. eg. TMP-STM1, TMS-16, TMP-DS3, TMP-16, TMP-32, TMP-64>  <adapter name e.g. TB002821>  <serial number e.g. TB002821>  <release used e.g V2.2.0 RC1>

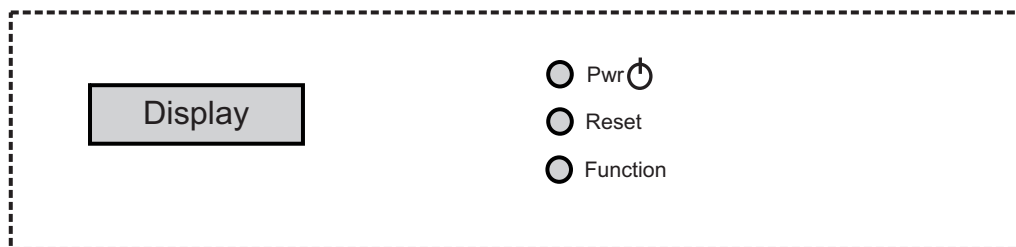

Figure 2.12 Front display and LEDs

If the reset button is pressed a software menu will appear on the display at the front of the unit. Press the function button to select one of the three actions listed in table 2.4 on page 23. Once your selection is made, press the reset button to acknowledge your choice.

Table 2.4 Reset Menu Options

Menu Choices	Description
M   Options:	
e   >Shutdown	Graceful shutdown of the TMG3200. This takes a few minutes. Press the reset button to restart the TMG3200.
n   Rst telecom	Reboots the telecom platform of the TMG3200.
u   Rst host	Reboots the linux host of the TMG3200

## 2.7 Powering Down

Powering down the TMG3200 requires that the Linux embedded host be shut down. In order to do this, you must connect to the management interface using SSH, and enter:

```
shutdown -h now
```

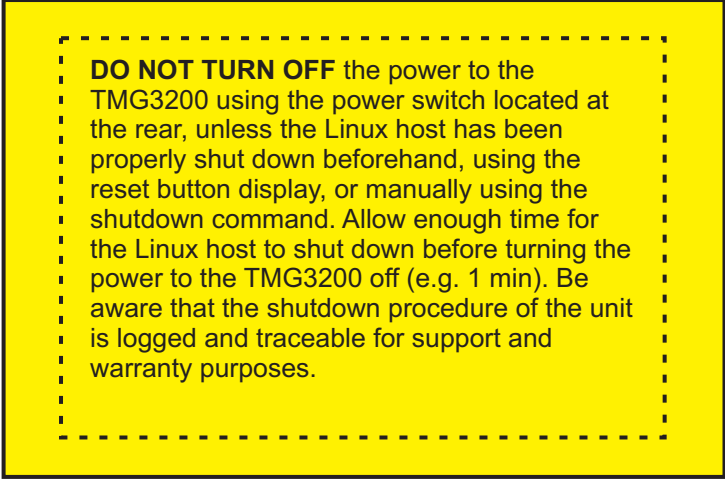

**DO NOT TURN OFF** the power to the TMG3200 using the power switch located at the rear, unless the Linux host has been properly shut down beforehand, using the reset button display, or manually using the shutdown command. Allow enough time for the Linux host to shut down before turning the power to the TMG3200 off (e.g. 1 min). Be aware that the shutdown procedure of the unit is logged and traceable for support and warranty purposes.

---

**Note** As an alternate method to this procedure, refer to Section 2.6.4 “Verifying the LED Status Indications” on page 23, to power down the TMG3200 with the reset button.

---

# Chapter 3 Initial System Configuration

This chapter provides the initial procedures that are required in order for you to be able to configure your TMG3200.

The following topics are covered:

- Configuring the TMG3200
- Setting the Time Zone
- Configuring the Toolpack System Using the Web Portal
- Changing TMG3200 Host IP Address
- Changing VoIP IP Interface Addresses
- Changing passwords

For information about Tblinux, a TelcoBridges™ Linux distribution running on the embedded host of the TMG3200, refer to the Telcobridges TB Wiki at:

<http://docs.telcobridges.com/mediawiki/index.php/Tblinux>

## 3.1 Configuring the TMG3200

The TMG3200 comes with the Toolpack and Media Gateway applications pre-installed. In order to make changes to system configuration, you must connect the front port (labelled Ethernet) of the TMG3200 to a terminal.

The IP address of the TMG3200 is assigned automatically through DHCP, however, default configurations can be changed manually.

The default hostname is the serial number of the embedded host. This can be found on the packing slip along the “TM-CPU-HOST” item.

If the hostname is not known, it can be found using the front serial connection. Login with a user name and password. This information is located on the shipment sheet. Type the command “hostname” or “ifconfig -a”:

```
[root@TB003540 ~]# hostname
```

```
TB003540
```

```
[root@TB003540 ~]# ifconfig -a
```

```
eth0 Link encap:Ethernet HWaddr 00:0C:38:00:0C:39
```

```
inet addr:10.0.0.236 Bcast:10.0.1.255 Mask:255.255.254.0
```

```
inet6 addr: fe80::20c:38ff:fe00:c39/64 Scope:Link
```

You can connect using the hostname or using the IP address assigned to eth0, using port 12358:

```
http://HOSTNAME:12358
```

```
For example: http://TB003540:12358
```



## 3.2 Setting the Time Zone

The time zone of the TMG3200 is configured on the Linux host using the *tzselect* command. The following is provided as a sample of how to configure a time zone.

```
[root@TB005375 ]# tzselect
Please identify a location so that time zone rules can be set correctly.
Please select a continent
1) Africa
2) Americas
.
.
.
10) None - I want to specify the time zone using the Posix TZ format.
#? 2
Please select a country.
1) Anguilla
.
.
.
10) Canada
.
.
.
51) Virgin Islands (US)
#? 10
Please select one of the time zone regions.
1) Newfoundland Time, including SE Labrador
.
.
.
7) Eastern Time - Quebec - most locations
.
.
.
27) Pacific Time - north Yukon
#? 7

The following information has been given:

    Canada
    Eastern Time - Quebec - most locations

Therefore TZ= 'America/Montreal' will be used.
Local time is now: Wed Aug 19 08:49:01 EDT 2009.
Universal time is now: Wed Aug 19 08:49:01 UDT 2009.
Is the above information OK?
1) Yes
2) No
#? 1

You can make this change permanent for yourself by appending the line
    TZ= 'America/Montreal'; export TZ
to the file '.profile' in your home directory; then log out and log in again.

Here is the TZ value again, this time on standard output so that you
can use the /usr/bin/tzselect command in the shell script
America/Montreal
[root@TB005373 ]#
```

## 3.3 Configuring the Toolpack System Using the Web Portal

To change the default configuration of the Toolpack system using the Web Portal, follow the steps described in the Web Portal System Configuration Tutorial Guide. This document can be obtained from TelcoBridges TB Wiki at:

[http://docs.telcobridges.com/mediawiki/index.php/Web\\_Portal\\_Tutorial\\_Guide\\_Versions](http://docs.telcobridges.com/mediawiki/index.php/Web_Portal_Tutorial_Guide_Versions)

The default login information for the Web Portal application is:

- Username: root
- Password: root

## 3.4 Changing the TMG3200 Host IP

A static IP address can be assigned to eth0, instead of using DHCP. To do this connect to the serial port (see Section 2.3 “Connecting to the Tmedia Management Interface” on page 9) and open the eth0 configuration file, using the procedure described in the Telcobridges TB Wiki at:

[http://docs.telcobridges.com/mediawiki/index.php/TBLinux:How\\_to\\_change\\_the\\_ip\\_address](http://docs.telcobridges.com/mediawiki/index.php/TBLinux:How_to_change_the_ip_address)

To return ETH0 to using DHCP, open the ETH0 configuration file, using the same procedure described in the Telcobridges TB Wiki at:

[http://docs.telcobridges.com/mediawiki/index.php/TBLinux:How\\_to\\_change\\_the\\_ip\\_address](http://docs.telcobridges.com/mediawiki/index.php/TBLinux:How_to_change_the_ip_address)

## 3.5 Changing VoIP Interface Addresses

The default address of the VoIP interfaces of the TMG3200 can be modified. To learn how this is done, refer to the Toolpack Web Portal tutorial guide on the Telcobridges TB Wiki at:

[http://docs.telcobridges.com/mediawiki/index.php/Web\\_Portal\\_Tutorial\\_Guide\\_Versions](http://docs.telcobridges.com/mediawiki/index.php/Web_Portal_Tutorial_Guide_Versions)

## 3.6 Changing Passwords

Once logged in to the TMG3200, type “passwd”, in order to change the password being used. The following information will be displayed:

```
[root@TB003540 ~]# passwd
Changing password for user root.
New UNIX password:
Retype new UNIX password:
passwd: all authentication tokens updated successfully.
```

# Chapter 4 System Upgrades

For information concerning system upgrades on a Telcobridges TMG3200, refer to the Toolpack Install Guide for TMG3200. This document can be found on the Telcobridges web site:

[http://docs.telcobridges.com/mediawiki/index.php/Upgrading\\_Toolpack'](http://docs.telcobridges.com/mediawiki/index.php/Upgrading_Toolpack)

## 4.1 Installing a New License

In order to install a new license on a Tmedia system, follow the steps described on the following internet page:

[http://docs.telcobridges.com/mediawiki/index.php/Add/Change\\_licenses](http://docs.telcobridges.com/mediawiki/index.php/Add/Change_licenses)

---

**Note:** A license upgrade will require that the TMG3200 be restarted.

---



# Chapter 5 Troubleshooting Tools

This chapter provides guidance in what actions to take when encountering system problems prior to contacting TelcoBridges Customer Support.

The following topics are covered:

- Connecting to the serial port of the TMG3200
- Configuring the terminal emulator application
- Reporting a Problem
- Preparing your setup information
- TbDebug Debug Dump Files
- Application Logs
- Backdoor Tools
- tbsigtrace signaling traces

## 5.1 Connecting to the Serial Port of the TMG3200

To view debug output data for a TMG3200, you must first physically connect your computer port to the serial port of the TMG3200.

### To connect to the serial port of a TMG3200:

1. Connect a CAT5 RJ-45 (male-male) cable (supplied with unit) between the com port of your computer and the serial port of the TMG3200 as shown in figure 5.1 on page 32. See figure 5.3 on page 33 for a RJ-45 pinout description.
2. If your computer's serial port features a DB9 connector, use the DB9 to RJ-45 adapter supplied with your TMG3200. If your computer's serial port features a USB connector, you will need to provide a USB to DB9 adaptor. Refer to figure 5.2 on page 32.

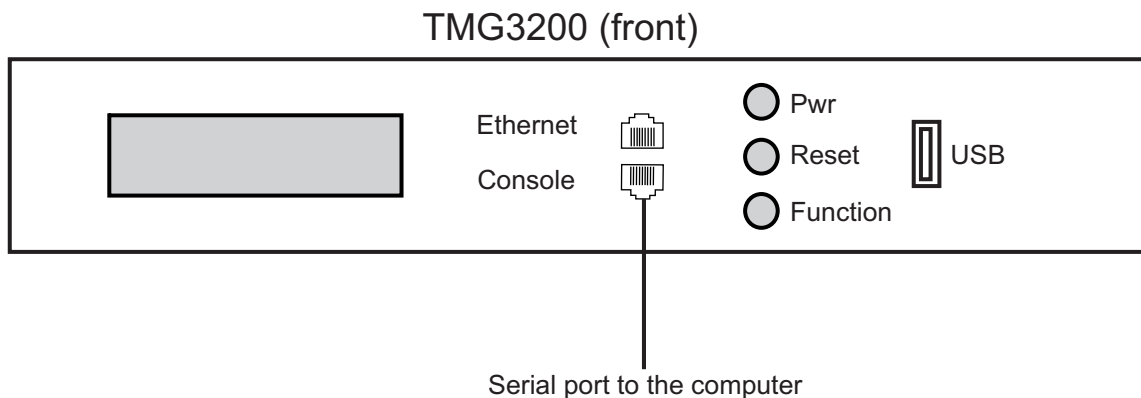

Figure 5.1 Computer to TMG3200 Serial Port Connection

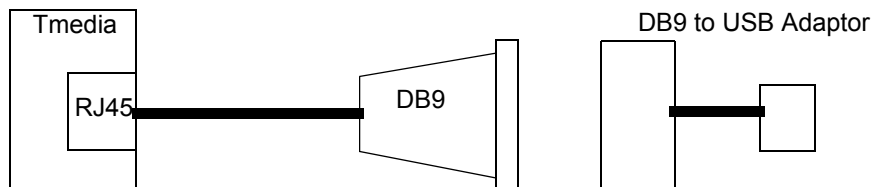

Figure 5.2 Conceptual View of a Serial Connection from the TMG3200 to a Computer

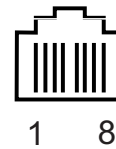
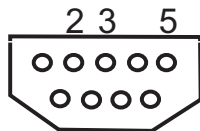
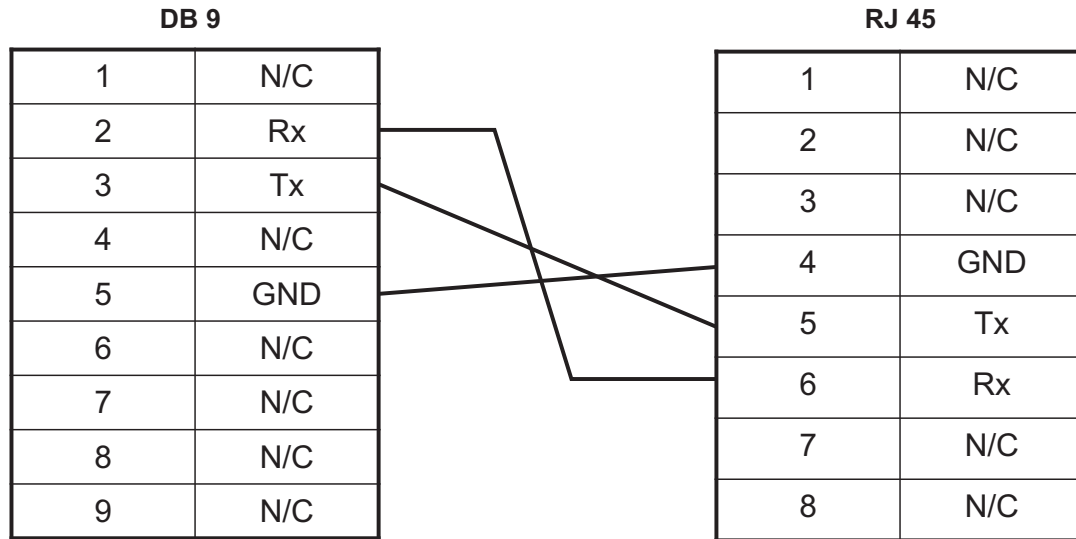

Figure 5.3 Console pinout

## 5.2 Configuring the Terminal Emulator Application

Before communicating with the Tmedia Management Interface, you must first configure a terminal emulator or console application to communicate with the TMG3200 in order to configure initial settings. Available terminal emulation software includes:

- HyperTerminal
- Putty
- Minicom

**To configure the terminal emulator application:**

1. Set the baud rate (bits per second) to **9600**
2. Set the data rate to **8 bits**
3. Set the parity to **None**
4. Set the stop bits to **1**
5. Set the flow control to **None**



## 5.3 Reporting a Problem

TelcoBridges has developed extensive tools to gather information about a Tmedia system to solve problems quickly. Users **MUST** gather all related logs before reporting a problem to TelcoBridges Support via Email or MSN. Various logging methods are described in the following sections.

Once information is gathered and sent to the TelcoBridges Support group ([support@telcobridges.com](mailto:support@telcobridges.com)), the Support group will assign a tracking number to the problem. All follow-up correspondence, whether it be by E-mail, MSN, or phone call must refer to the tracking number which the problem has been assigned.

## 5.4 Setup Information

The setup information must include:

- Physical connections. If necessary, describe it in a network diagram.
- Specifying that your product is a TMG3200.
- Telecommunication connectivity diagram (for example: E1/T1/J1, DS3, STM-1/OC-3, VoIP Ethernet switch, etc)
- Remote access to system (SSH, VPN, VNC, Remote desktop, etc.)
- For a signaling-related problem, specify which side is initiating the call

## 5.5 Tbdebug Dump Files (Mandatory)

The tbdebug copies information about Telcobridges libraries and TMG3200 into log files. This includes software, the release running on the host, the firmware release running on the TMG3200, and other TMG3200 information, such as: available features, configuration, and status information.

The tbdebug files must be sent when a problem is reported. If the problem is reproducible, the tbdebug dump files are verified before and after the problem is reproduced. This will aid in identifying the problem quickly.

For further information about Tbdebug, refer to Telcobridges TB Wiki at:

[http://docs.telcobridges.com/mediawiki/index.php/Toolpack\\_Debug\\_Application:Tbdebug](http://docs.telcobridges.com/mediawiki/index.php/Toolpack_Debug_Application:Tbdebug)

## 5.6 Application Logs

All Toolpack applications will produce logs. The trace level can be set to vary the amount of logs that are received from the system. Trace level 0 is the most verbose and 4 is the least. Important errors are always logged.

`/lib/tb/toolpack/setup/[major version]/apps/gateway` (Or customer's application)

```
tblogtrace
tboamapp
tbstreamserver
toolpack_engine
toolpack_sys_manager
/lib/tb/toolpack/
tbtoolpack_service
```

```
/lib/tb/toolpack/pkg/[minor version]/web  
Log  
Database dump:  
mysqldump -u [DbUserName] -password=[DbPassword] -opt toolpack_0 > toolpack_0.sql  
  
For example: mysqldump -u tbdb -password=tbdbpw -opt toolpack_0 > toolpack_0.sql
```

---

**Note** This can be obtained from the web portal or by using the tbdebug command.

---

## 5.7 Backdoor Tools

A number of backdoor tools are available as follows:

- `tbx_cli_tools_remote`
- `tbshows`
- VoIP Traffic Capture
- Wireshark
- `tbstreamlisten`
- Stream server audio packets to wave file
- `tbsigtrace`

### 5.7.1 `tbx_cli_tools_remote`

The `tbx_cli_tools_remote` tool can be used to get the text-based GUI control of TB applications like `Toolpack_Engine`, `Toolpack_sys_manager`, `tbstreamserver`, and others which are run in background.

For further information about `tbx_cli_tools`, refer to Telcobridges TB Wiki at:

[http://docs.telcobridges.com/mediawiki/index.php/Toolpack\\_Application:tbx\\_cli\\_tools\\_remote](http://docs.telcobridges.com/mediawiki/index.php/Toolpack_Application:tbx_cli_tools_remote)

## 5.7.2 Line/Trunk Status (Tbshows)

```
tbshows (/tb/bin/release/[OS version]/)
```

tbshows can be used to show trunk alarm and performance counters. The tool will check the trunk status periodically to show the most updated trunk status. Users can use the up/down/left/right arrow keys to show the performance data on different trunks. Use a-s-d-x to scroll and view other lines services.

Options 'G' and 'S' enable you to get and set the trunk interface parameters.

Option 'R' can be used to reset the performance counter value to zero.

It is also possible to allocate all line interfaces in different configurations. This is useful for DS3 and OC3/STM-1 configurations, in order to help users understand the configuration.

---

**Note** Trunk status and alarms can be viewed from the *Status* menus of the Web Portal.

---

## 5.7.3 VoIP Traffic Capture

When troubleshooting VoIP related issues, a direct Ethernet connection can be established between the host's Gigabit Ethernet interface and the VoIP1 interface on the TMG3200. Wireshark is connected on the Gigabit Ethernet interface on the host server.

### To capture VoIP Traffic, do the following:

1. Connect VoIP1 interface to Ethernet port of a server
2. Connect to the telecom platform
  - 2a. Using telnet, for example: [root@TB005375 ]# telnet 172.31.1.1  
or
  - 2b. Using minicom, for example: [root@TB005375 ]# minicom
3. Type this command:

```
mv88eMonitor 0x4 0x4 3 (Copies everything from VoIP0 to VoIP1) *
```

4. Start pcap capture on the server Ethernet port (either wireshark or tcpdump)
5. To stop the tracing:

```
mv88eMonitor 0 0 3
```

## 5.7.4 Wireshark (formerly called Ethereal)

Wireshark is useful for capturing both VoIP traffic as well as Streamserver packets (play/record function).

This program is available at this site: [www.wireshark.org](http://www.wireshark.org)

## 5.7.5 Tbstreamlisten

tb\apps\tbstreamlisten\release\[OS version]

This allows the recording of the raw data from a TDM stream. Please ask customer support for instructions regarding this function.

## 5.7.6 Stream Server Audio Packets to Wave File

It is possible to capture all audio packets transmitted to and from the Stream Server and to convert them into wave files for analysis. You can use Wireshark or tcpdump on the server running the tbstreamserver application.

The conversion tool, streamserver\_pkt\_to\_wav can be found at the following location:

/tb/bin/release/[OS version].

## 5.7.7 tbsigtrace Signaling Traces

The tbsigtrace program is a tool used to capture SS7, ISDN, and SIP signaling.

---

**Note** This application can be started with Toolpack. For further information, refer to the TelcoBridges TB Wiki at:  
[http://docs.telcobridges.com/mediawiki/index.php/Toolpack\\_Debug\\_Application:Tbsigtrace](http://docs.telcobridges.com/mediawiki/index.php/Toolpack_Debug_Application:Tbsigtrace)

---