

TMP6400 Development Platform System Installation Guide

Issue 3.0d

The information in this document as well as product specifications referred to throughout, are subject to change without notice. No part of this document may be reproduced or transmitted in any form or by any means, electronic or mechanical, for any purpose, without the express written permission of TelcoBridges. TelcoBridges may have patents or pending patent applications, trademarks, copyrights, or other intellectual property rights covering subject matter in this document. The furnishing of this document does not give you license to these patents, trademarks, copyrights, or other intellectual property except as expressly provided in any written license agreement from TelcoBridges Inc.

The information provided in this document is intended as a guide only. For the latest detailed engineering specifications, please contact TelcoBridges TB Support or visit the TBWiki: <http://docs.telcobridges.com>. TelcoBridges is committed to continually improving product designs; as a result, product specifications may be subject to change without notification.
© 2003-2012 TelcoBridges. All rights reserved.

TelcoBridges, Tmedia, TMG800, TMG3200-RJ, TMG3200-TE, TMG3200-DS3, TMG3200-STM1, TMG7800-TE, TMG7800-DS3, TMG7800-STM1, TMG7800-CTRL, TMG-CONTROL, TMG7800-TMS, Tmedia 1+1, TMG800+1, TMG3200-RJ+1, TMG3200-TE+1, TMG3200-DS3+1, TMG3200-STM1+1, TMG7800-TE+1, TMG7800-DS3+1, TMG7800-STM1+1, Tdev, TMP800, TMP6400, TMP6400-CTRL, TMP6400-TMS, Tmonitor, TM1000, Toopack, Toolpack API, TB640, TB-8, TB-16, and TB-Video, are trademarks of TelcoBridges Inc. All other trademarks are the property of their owners. This information is subject to change without notice.

HEAD OFFICE
TelcoBridges Inc.
91 rue de la Barre, Suite 01
Boucherville, QC, J4B 2X6
CANADA
www.telcobridges.com

T +1 450 655 8993
F +1 450 655 9511
info@telcobridges.com

TB Support -Technical Support
Tel: +1 438 338 2100
support@telcobridges.com
www.telcobridges.com/en/tbsupport.aspx

Preface

About this Guide

This guide provides installation, and setup procedures for the Tdev TMP6400 Development Platform.

Conventions

Terminology	Description
Tdev TMP6400 Development Platform	This term is used when a description applies to the Tmedia system comprised of the TMP6400-CTRL, TMP6400 Telecom Unit, and TMP6400-TMS.
TMP6400-CTRL	This term is used when a description applies specifically to the TMP6400-CTRL gateway controller.
TMP6400 Telecom Unit	This term is used when a description applies to all variations of the TMP6400 Telecom Units (TE, DS3, STM1).
TMP6400-TMS	This term is used when a description applies specifically to the TMP6400-TMS media switch.

Contact Us

If you have comments about this guide or any other TelcoBridges technical documentation, please send an email to marketing@telcobridges.com.

Table of Contents

Chapter 1	Introduction	1
1.1	Identifying the Tdev TMP6400 Development Platform Equipment.....	2
1.2	Installation Prerequisites	4
1.2.1	TMP6400-CTRL	4
1.2.2	TMP6400 Telecom Units.....	5
1.2.3	TMP6400-TMS	5
1.3	Preventing Electrostatic Discharge Damage.....	5
1.4	Recommended Reading	6
Chapter 2	Installing the Equipment.....	7
2.1	Package Contents.....	8
2.1.1	TMP6400-CTRL Gateway Controllers.....	8
2.1.2	TMP6400 Telecom Unit	9
2.1.3	TMP6400-TMS Media Switch.....	10
2.2	Rack Mounting the Tdev TMP6400 Development Platform Equipment.....	11
2.2.1	Prerequisites	11
2.2.2	Vertical Placement of Tdev TMP6400 Development Platform Equipment.....	11
2.2.3	Installing the Tdev TMP6400 Development Platform on an Equipment Rack.....	12
2.2.3.1	TMP6400-CTRL	12
2.2.3.2	TMP6400 Telecom Units.....	22
2.2.3.3	TMP6400-TMS	22
2.3	TMP6400-CTRL	23
2.3.1	Connecting to the System Management Interface	24
2.3.2	Connecting to the Tmedia Control Network	25
2.3.3	Powering Up.....	26
2.3.3.1	Connecting to AC Power	26
2.3.3.2	Connecting to DC Power.....	27
2.4	TMP6400 Telecom Unit	28
2.4.1	Connecting to the Tmedia Control Network	29
2.4.2	Connecting to the VoIP Network(s).....	30
2.4.3	Connecting to the PSTN	31
2.4.3.1	SCSI Interface (T1/E1) for the TMP6400-TE	32
2.4.3.2	Dual BNC Interface (DS3) for the TMP6400-DS3.....	34
2.4.3.3	Optical Interface (OC3/STM-1) for the TMP6400-STM1	35
2.4.4	Connecting to the TMS Network	36
2.4.4.1	Connecting to the TMP6400 Telecom Units.....	36
2.4.4.2	Interconnecting Two TMP6400 Telecom Units	38
2.4.5	Powering Up.....	39
2.4.5.1	Connecting to AC Power	39
2.4.5.2	Connecting to DC Power.....	40
2.5	TMP6400-TMS	41
2.5.1	Connecting to the Tmedia Control Network	41
2.5.2	Powering Up.....	42
2.5.2.1	Connecting to AC Power	42
2.5.2.2	Connecting to DC Power.....	43

2.5.3	TDM System Clock.....	43
2.6	Start Up	44
2.6.1	Primary	44
2.6.2	Secondary	46
2.7	Verifying the LED Status Indications	48
2.7.1	TMP6400-CTRL	48
2.7.2	TMP6400 Telecom Unit	48
2.7.3	TMP6400-TMS	50
2.8	Powering Down	51
2.8.1	TMP6400-CTRL	51
2.8.2	TMP6400 Telecom Unit	51
2.8.3	TMP6400-TMS	51
Chapter 3	Initial System Configuration	53
3.1	Connecting to the Serial Port of the Tdev Development Platform.....	54
3.1.1	Connecting to the Serial Port of the TMP6400-CTRL	54
3.1.2	Connecting to the Serial Port of the TMP6400 Telecom Unit.....	55
3.2	Configuring the Terminal Emulator Application	56
3.3	Connecting to the Tdev Development Platform.....	56
3.4	Retrieving Tdev Development Platform Information.....	57
3.5	Changing the Tdev Development Platform Management Port IP Address	57
3.6	Changing Tdev Development Platform Management Port Passwords	57
3.7	Setting the Time Zone	57
3.8	Configuring the Tdev Development Platform Using the Web Portal	58
3.9	Changing VoIP Interface Addresses	58
Chapter 4	System Backups	59
4.1	Creating a Database Backup	60
4.2	Downloading a Database Backup	60
4.3	Uploading a Database Backup.....	60
4.4	Restoring a Database Backup	60
Appendix A	Wiring Diagrams.....	61
A.1	RJ48C Wiring Diagram: Crossover and Straight Cables.....	62
A.2	RJ48 Console Wiring Diagram	63

Chapter 1 Introduction

This chapter provides an introduction to the installation and setup of a Tdev TMP6400 Development Platform:

The following topics are covered:

- Section 1.1 “Identifying the Tdev TMP6400 Development Platform Equipment”
- Section 1.2 “Installation Prerequisites”
- Section 1.3 “Preventing Electrostatic Discharge Damage”
- Section 1.4 “Recommended Reading”

1.1 Identifying the Tdev TMP6400 Development Platform Equipment

The Tdev TMP6400 Development Platform is comprised of the following equipment:

- One (1) or two (2) TMP6400-CTRL gateway controller(s). See figure 1.1 on page 2.
- One (1) to 16 TMP6400 Telecom Unit(s). See figure 1.2 on page 3.
- Based upon the configuration of your Tdev TMP6400 Development Platform, the number of TMP6400-TMS media switch(es) may range from zero (0) to two (2). See figure 1.3 on page 3.

TMP6400-CTRL (outer view)

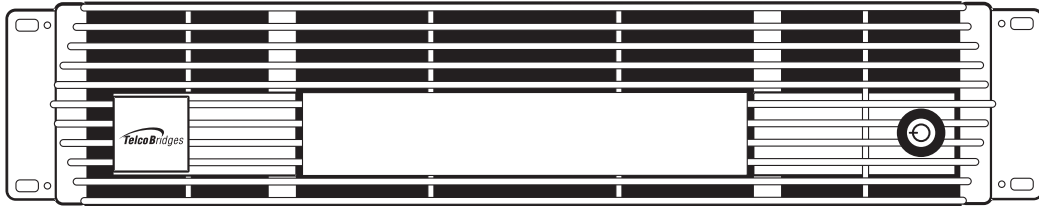

TMP6400-CTRL (inner view)

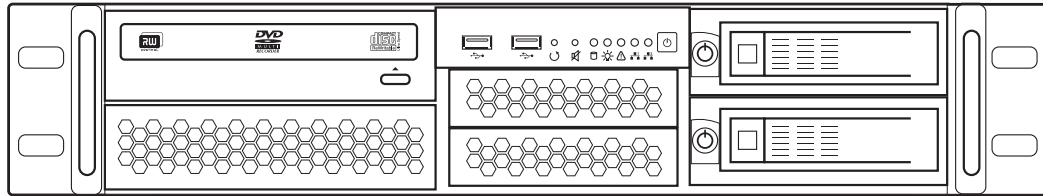
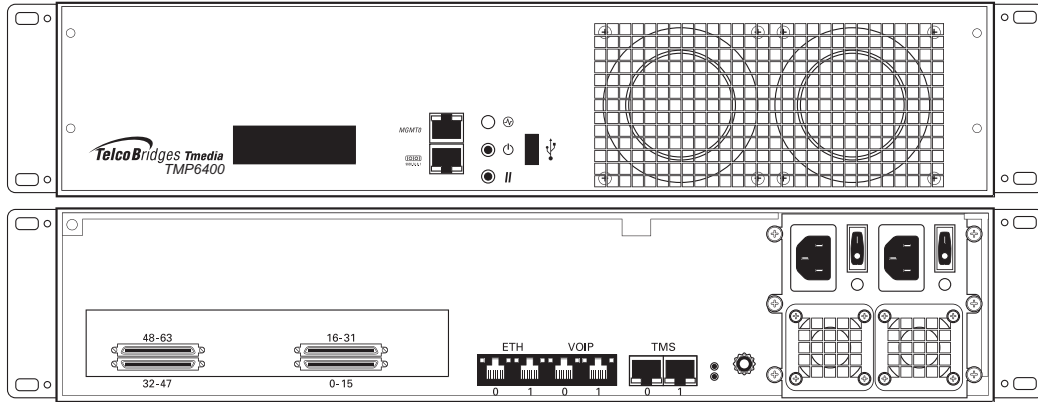
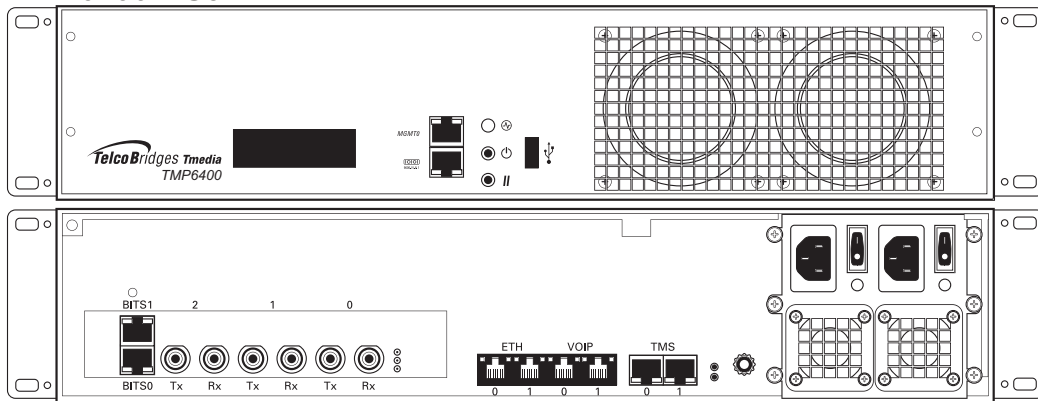

Figure 1.1 TMP6400-CTRL Front Views

TMP6400-TE



TMP6400-DS3



TMP6400-STM1

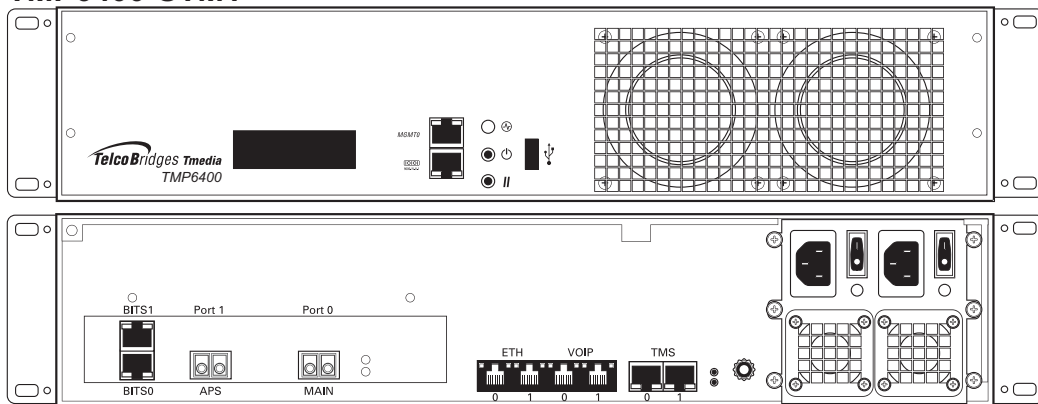

Figure 1.2 TMP6400 Telecom Units Front and Rear Views

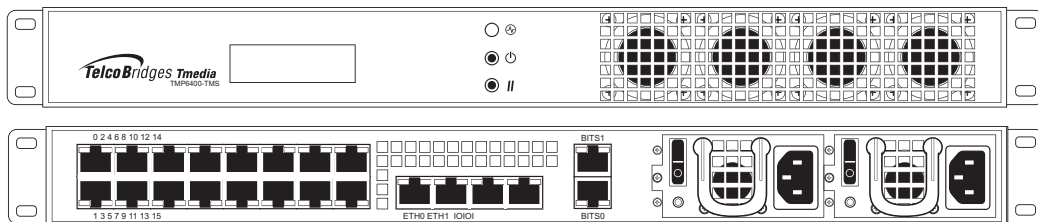

Figure 1.3 TMP6400-TMS Front and Rear Views

Adequate power supply and power connections

Each TMP6400-CTRL requires two power connections to provide for its redundant power supply. To guarantee an uninterrupted supply of electricity, each power connection must be fed by a dedicated power source.

An IP address for the management port

Each TMP6400-CTRL requires a IP address for the management port. To avoid delays, you should have the IP address, netmask and gateway addresses on hand. Take note that the management port supports DHCP, see Section 2.3.1 “Connecting to the System Management Interface” on page 24 for further information.

Cabling

Three (3) customer supplied ethernet cables are required for each TMP6400-CTRL to connect the TMP6400-CTRL to the switches.

1.2.2 TMP6400 Telecom Units

Adequate space for the installation of each TMP6400 Telecom Unit

You will need to mount each TMP6400 Telecom Unit (1-16 units) on a 19" equipment rack (customer provided). Each TMP6400 Telecom Unit is housed in a 2U chassis.

Adequate power supply and power connections

Each TMP6400 Telecom Unit requires two power connections to provide for its redundant power supply.

To guarantee an uninterrupted supply of electricity, each power connection must be fed by a dedicated power source.

1.2.3 TMP6400-TMS

Adequate space for the installation of the TMP6400-TMS

You will need to mount the TMP6400-TMS on a 19" equipment rack (customer provided). Your TMP6400-TMS is a 1U unit. Plan for an additional 1U space on the equipment rack for a redundant TMP6400-TMS.

Adequate power supply and power connections

Each TMP6400-TMS requires two power connections to provide for its redundant power supply. To guarantee an uninterrupted supply of electricity, each power connection must be fed by a dedicated power source.

1.3 Preventing Electrostatic Discharge Damage

Electrostatic discharge (ESD) can damage equipment and impair electrical circuitry. It may occur if electronic printed circuit cards are improperly handled and may cause complete or intermittent failure.



Warning

Always follow ESD prevention procedures when removing and replacing modules:

- Ensure that the Tdev Development Platforms are grounded.
 - Wear an ESD-preventive wrist strap and ensure that it makes good contact with your skin. Connect the wrist strap clip to an unpainted surface of the Tdev Development Platform or the grounded equipment rack in order to channel away all ESD voltage safely to ground. To guard against ESD damage and shocks, the wrist strap and cord must be in proper working condition.
 - If no wrist strap is available, and you must work with Tdev Development Platforms, ground yourself by touching a metal part of the chassis.
-

1.4 Recommended Reading

This document assumes that you have a clear understanding of the installation of the TelcoBridges Tdev Development Platforms and have been trained to work with the equipment. If you have any technical questions, TelcoBridges TB Support (technical support team) can be reached via telephone (+1 866 438 4703) or email: support@telcobridges.com.

Documents exploring various aspects of the Tmedia system are available on the TB Wiki: <http://docs.telcobridges.com>

Chapter 2 Installing the Equipment

This chapter provides information about the following topics:

- Section 2.1 “Package Contents”
- Section 2.2 “Rack Mounting the Tdev TMP6400 Development Platform Equipment”
- Section 2.3 “TMP6400-CTRL”
- Section 2.4 “TMP6400 Telecom Unit”
- Section 2.5 “TMP6400-TMS”
- Section 2.7 “Verifying the LED Status Indications”
- Section 2.8 “Powering Down”

2.1 Package Contents

Depending on your system requirements, you may receive one or more of the following items:

- Section 2.1.1 “TMP6400-CTRL Gateway Controllers” on page 8.
- Section 2.1.2 “TMP6400 Telecom Unit” on page 9.
- Section 2.1.3 “TMP6400-TMS Media Switch” on page 10.

The contents of these devices are described in the following sections.

2.1.1 TMP6400-CTRL Gateway Controllers

In the TMP6400-CTRL box, you will find the following items:

- One (1) TMP6400-CTRL. See figure 1.1 on page 2.
- Four (4) keys.
- One (1) front bezel.
- Two (2) hard drives.
- Two (2) power cords.
- One Product Warranty.
- One Important Notice (two-sided document containing pertinent product serial numbers and other important information).
- One (1) packing slip.
- One (1) set of sliding rails and associated screws.
- One (1) set of brackets and associated screws.

Not included

- Ethernet cables.

2.1.2 TMP6400 Telecom Unit

In the TMP6400 Telecom Unit box, you will find the following items:

- One (1) TMP6400 unit (TMP6400-TE, TMP6400-DS3, or TMP6400-STM1). See figure 1.2 on page 3.
- One (1) set of mounting brackets and screws, used to mount the TMP6400 to a 19" rack.
- One (1) DB-9 to RJ-45 adapter to interface the serial port of your computer with the RJ-45 port of the TMP6400.
- Three (3) CAT5 Ethernet (blue) straight cables (male-male), 3 meters in length.
- One (1) Important Notice (two-sided document containing pertinent product serial numbers, and other important information).
- One (1) Product Warranty.
- One (1) packing slip.
- One (1) Quick Installation Guide (two-sided document that provides a pictorial view of the equipment setup).
- Two (2) AC or DC power cables

Specifically with the TMP6400-TE, you will also have:

- One (1) or two (2) patch panel(s)
- Two (2) SCSI cables per patch panel.

Not included

- A 19" equipment rack. The Tdev TMP6400 Development Platform must be installed on a 19" wide equipment rack.

2.1.3 TMP6400-TMS Media Switch

In the TMP6400-TMS media switch box, you will find the following items:

- One (1) TMP6400-TMS unit. See figure 1.3 on page 3.
- Three (3) CAT5 Ethernet (blue) straight cables (male-male), 3 meters in length.
- One (1) DB-9 to RJ-45 adapter to interface the serial port of your computer with the RJ-45 port of the TMP6400-TMS.
- One (1) set of mounting brackets and screws, used to mount the TMP6400-TMS to a 19" rack.
- One (1) Important Notice (two-sided document containing pertinent product serial numbers, and other important information).
- One (1) Product Warranty.
- One (1) packing slip.
- One (1) Quick Installation Guide (two-sided document that provides a pictorial view of the equipment setup).
- Two (2) AC or DC power cables

Not included

- A 19" equipment rack. The TMP6400-TMS must be installed on a 19" wide equipment rack.

2.2 Rack Mounting the Tdev TMP6400 Development Platform Equipment

The Tdev TMP6400 Development Platform equipment is mounted on a customer provided equipment rack using the mounting hardware packaged in each box.

2.2.1 Prerequisites

To rack mount the equipment, you will need:

- One customer-provided equipment rack, measuring 19" in width and 31.5" in depth. The rack must be solidly anchored to the floor with appropriate support at the top of the racks.
- Climate controlled room: 0 to +50 Celsius, 0 to 95% non-condensing humidity.

2.2.2 Vertical Placement of Tdev TMP6400 Development Platform Equipment

The TMP6400-CTRL and TMP6400 Telecom Units are each housed in a 2U chassis, while the TMP6400-TMS is housed in a 1U chassis, as tabulated in table 2.1 on page 11. It is important that you provide for enough room on the equipment rack to allow for the installation of the equipment.

Consider the available space on your equipment rack and the height of one (1) or two (2) TMP6400-CTRL unit(s), one (1) to sixteen (16) TMP6400 Telecom Unit(s), and from zero (0) to two (2) TMP6400-TMS units. Due to the rear-exhaust heat vents and the efficient heat dissipation design, there is no need to leave any physical vertical space above or below the TMP6400-CTRL unit(s), TMP6400 Telecom Unit(s), and the TMP6400-TMS unit(s) on the equipment rack.

Table 2.1 Tdev Development Platform Physical Height

Tmedia Model Number	Vertical Height
TMP6400-CTRL	2U (3.5 inches or 89.10 mm)
TMP6400 Telecom Unit	2U (3.5 inches or 89.10 mm)
TMP6400-TMS	1U (1.75 inches or 44.45 mm)
Patch Panels	1U (1.75 inches or 44.45 mm)

2.2.3 Installing the Tdev TMP6400 Development Platform on an Equipment Rack

The TMP6400-CTRL, TMP6400 Telecom Unit, and TMP6400-TMS are mounted on a 19" equipment rack using the angle brackets and screws provided in the box.

2.2.3.1 TMP6400-CTRL

Mounting the TMP6400-CTRL Unit(s):

The TMP6400-CTRL is installed in a 19" equipment rack using one of the following two methods:

Method One: Slider Rails

1. Install the left sliding rail on the left-hand side of the equipment rack.
 - 1a. Attach the front end of the slider rail to the front edge of the equipment rack. See figure 2.1 on page 13.
 - 1b. Attach the rear end of the slider rail to the rear edge of the equipment rack. See figure 2.2 on page 13 and figure 2.3 on page 14.
2. Repeat Step 1 to install the right sliding rail on the right-hand side of the equipment rack.
3. Extend both sliding rails. See figure 2.4 on page 14.
4. Attach the TMP6400-CTRL to the rails. See figure 2.5 on page 15 and figure 2.6 on page 15.
5. Push the TMP6400-CTRL back into the equipment rack until it locks into place.

Note To unlock the rails and slide the TMP6400-CTRL outwards from the equipment rack, depress the purple colored buttons on each side of the sliding rails.

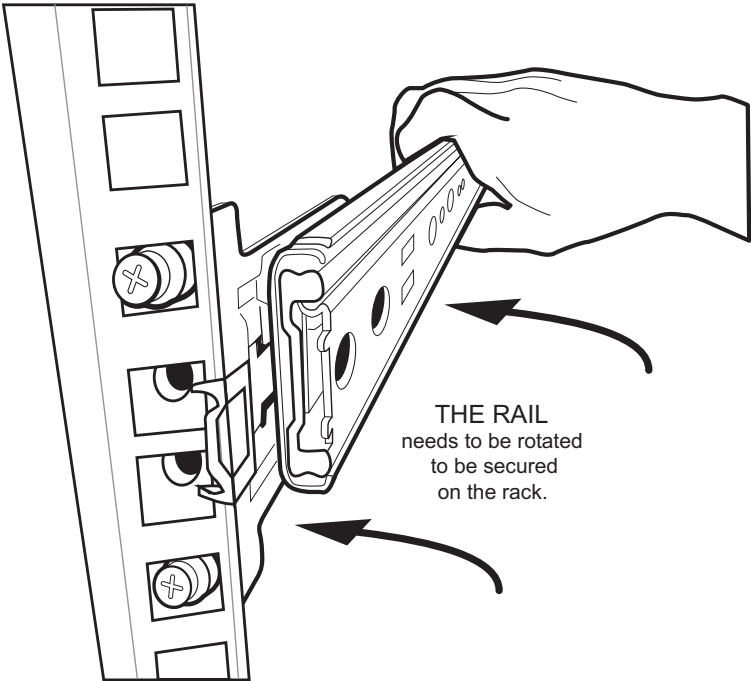

Figure 2.1 Securing the Slider Rail to the Front of the Equipment Rack

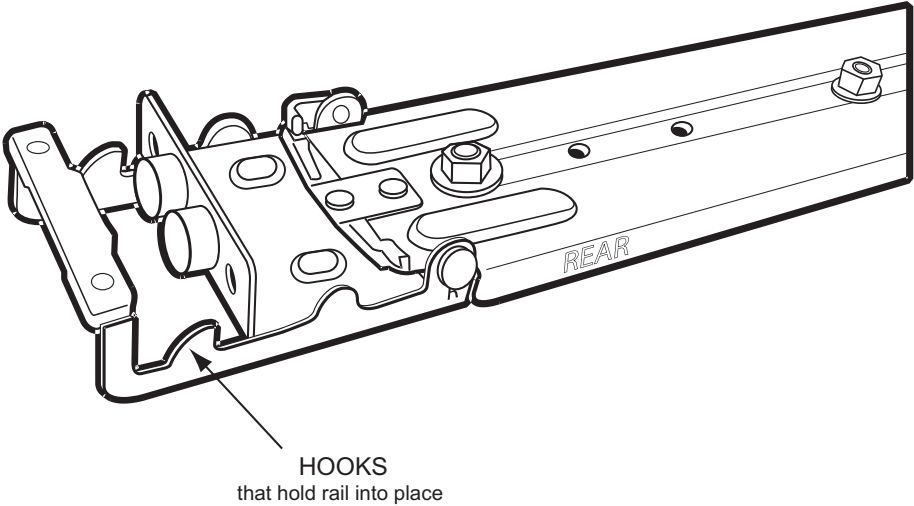

Figure 2.2 Detail View of Slider Rail Rear Retaining Hooks

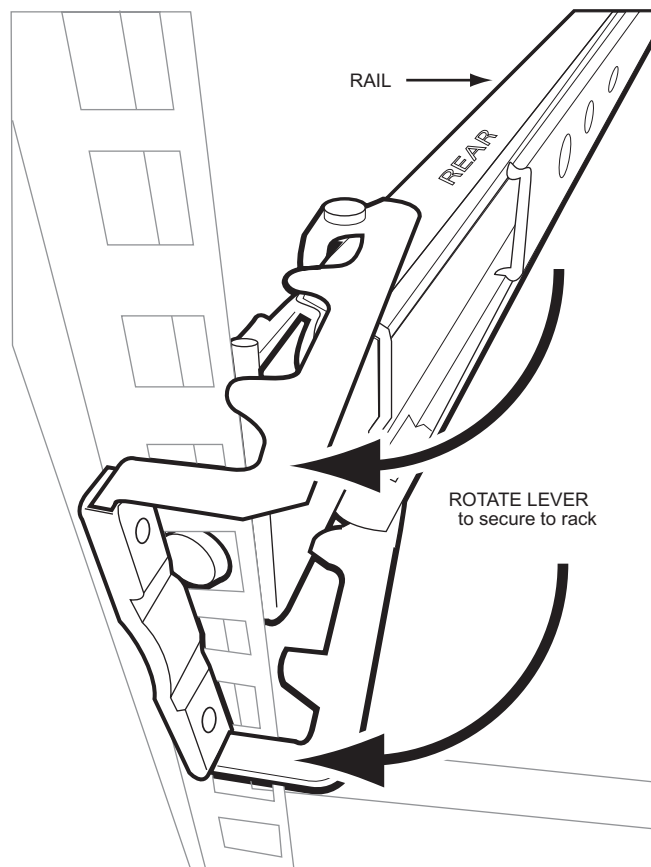

Figure 2.3 Detailed View of Slider Rail Rear Retaining Hooks being Locked onto the Rear of the Equipment Rack

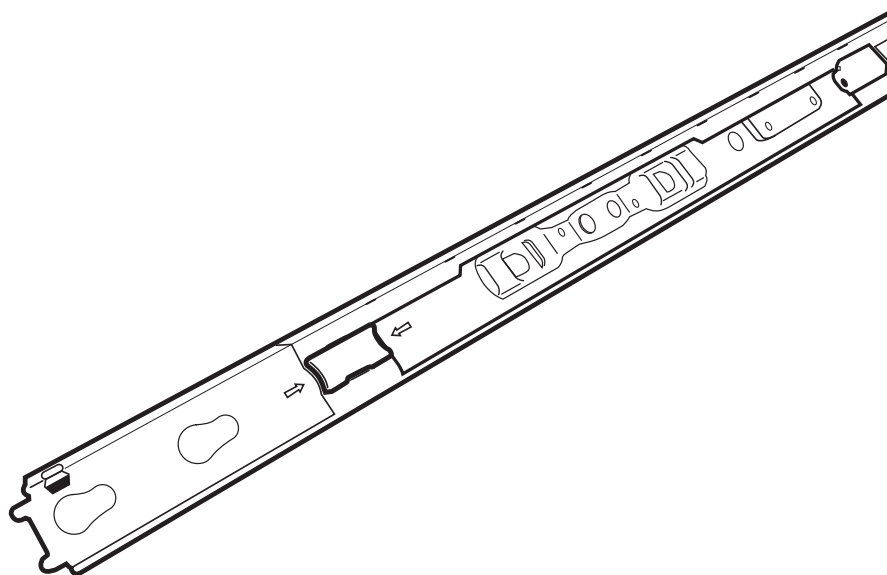

Figure 2.4 Detailed View of the Slider Rail Release Mechanism

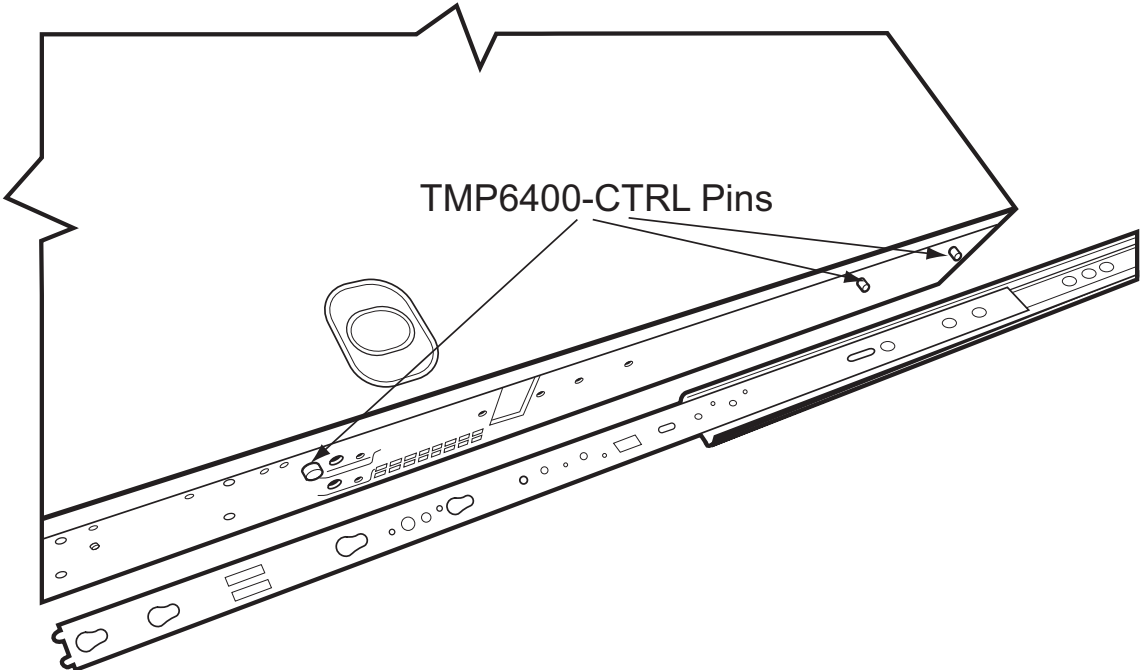

Figure 2.5 Attaching Sliding Rails to the TMP6400-CTRL Mounting Pins

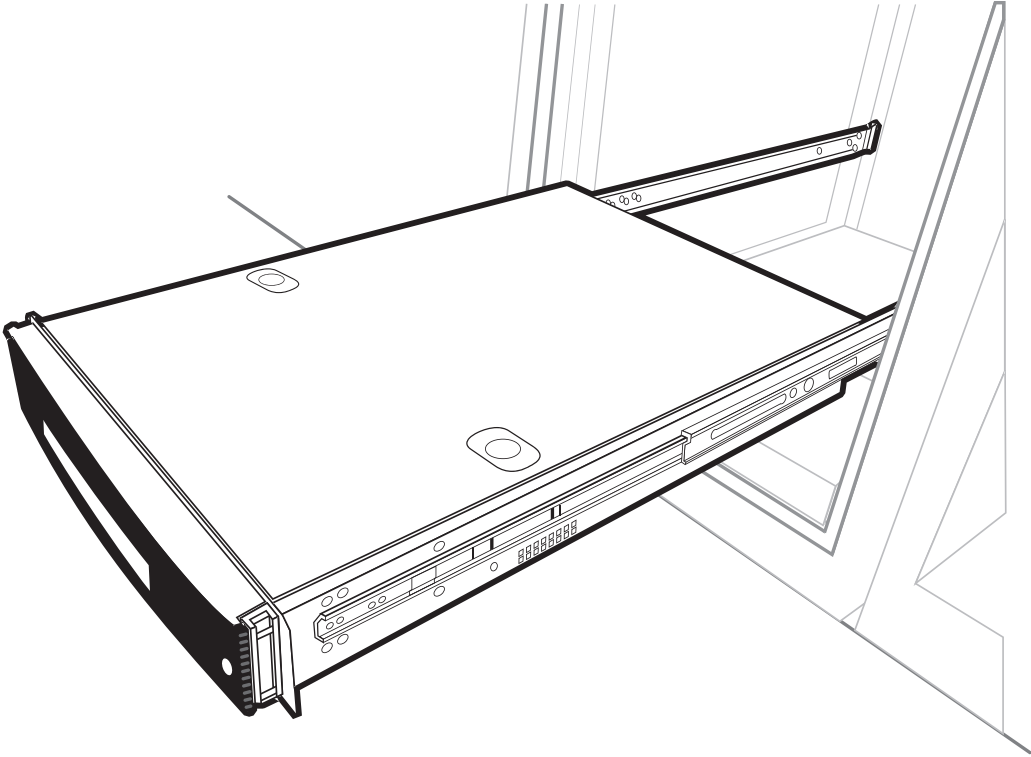

Figure 2.6 TMP6400-CTRL Installed on Slider Rails in the Fully Extended Position

Method Two: Fixed Brackets

1. Install the fixed brackets on the TMP6400-CTRL, adjusting their position in accordance with the equipment rack depth. See figure 2.7 on page 16.
2. Mount the TMP6400-CTRL on the equipment rack.
3. Secure it in place using the screws provided with the bracket. See figure 2.8 on page 16 and figure 2.9 on page 17.

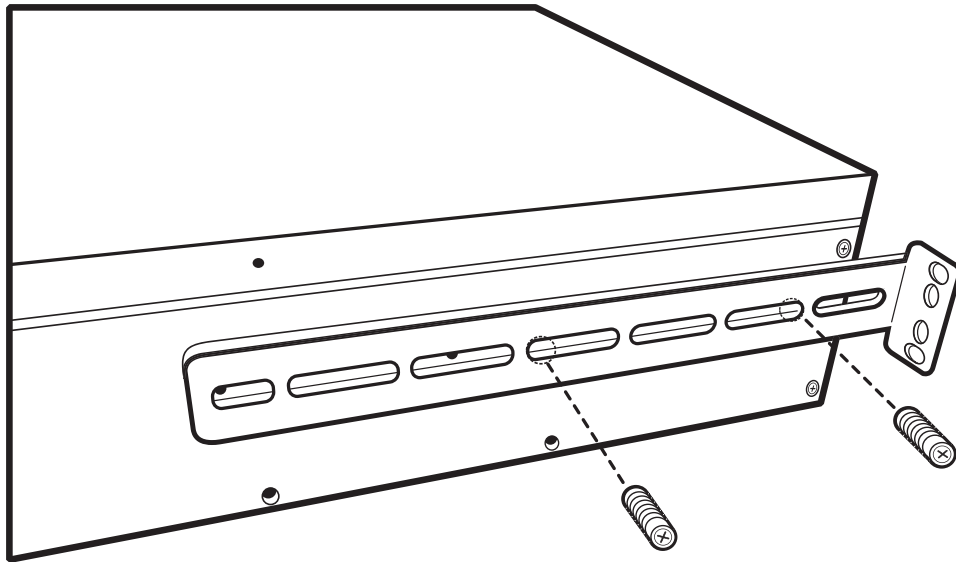

Figure 2.7 Attaching the Rear Brackets to the TMP6400-CTRL

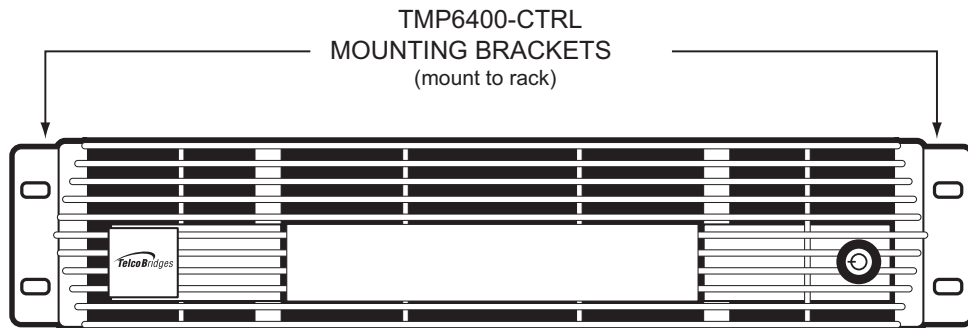

Figure 2.8 Front View of TMP6400-CTRL with Front Mounting Brackets

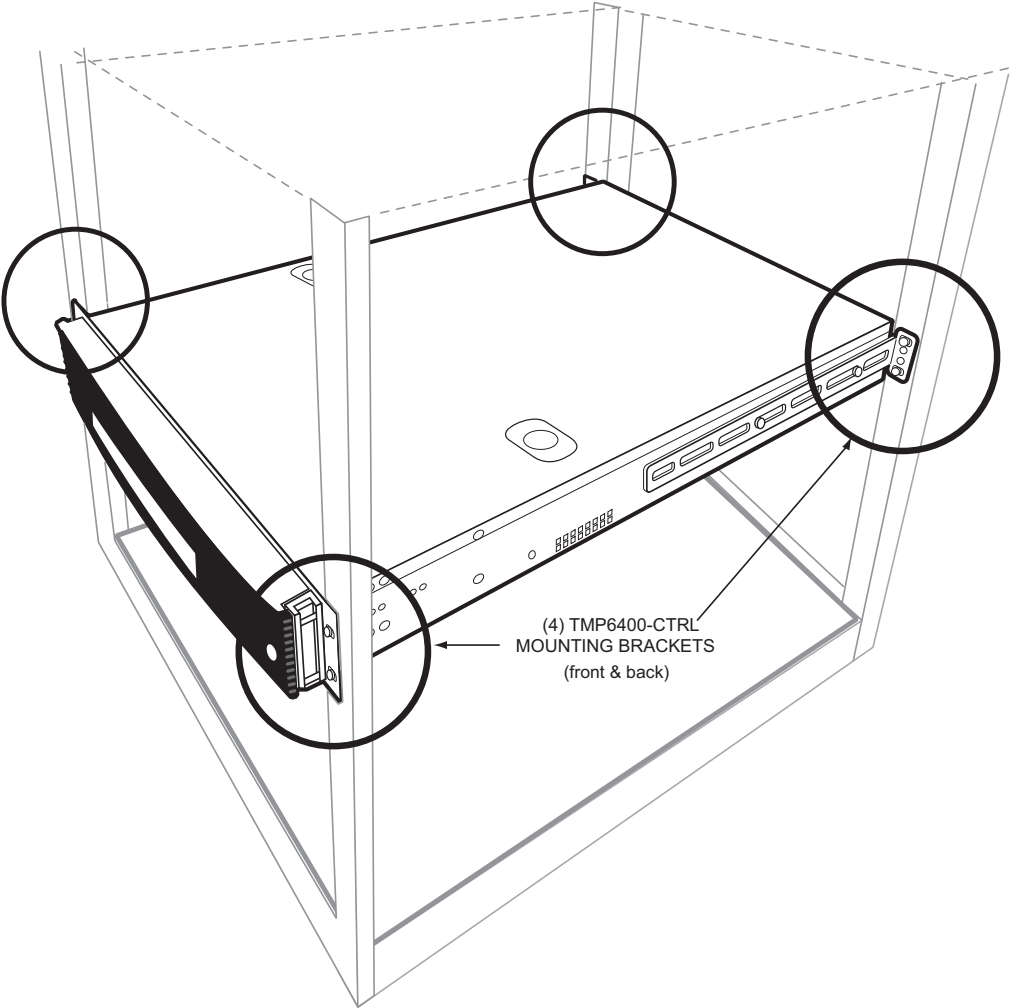

Figure 2.9 TMP6400-CTRL Installed in the Equipment Rack

Installing the Hard Drives

To install the hard drives, do the following:

1. Using the bezel key, unlock and remove the TMP6400-CTRL front bezel. See figure 2.10 on page 18, figure 2.12 on page 19, and figure 2.13 on page 19.
2. Using the hard disk key, open the top hard disk tray. See figure 2.14 on page 20, and figure 2.15 on page 20.
3. Insert the top disk drive. See figure 2.11 on page 18 and figure 2.16 on page 21.
4. Close the top hard disk tray. See figure 2.17 on page 21.
5. Repeats steps 2-4 to install the bottom disk drive.
6. Reinstall the front bezel.

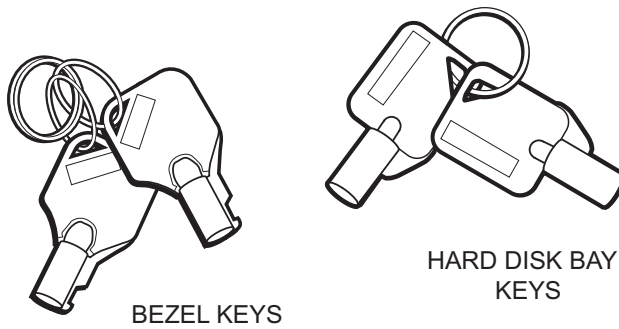

Figure 2.10 Bezel and Hard Disk Keys

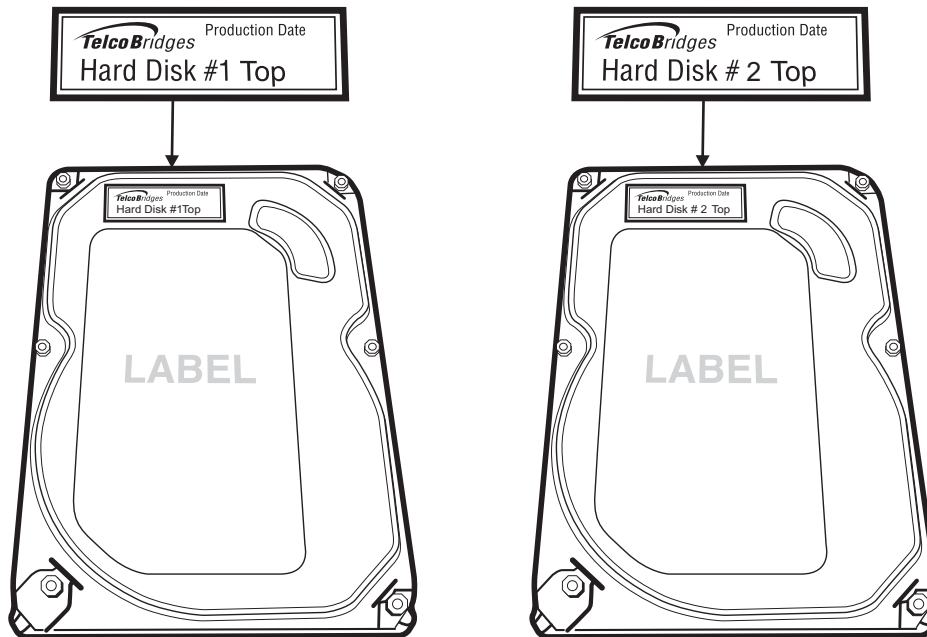

Figure 2.11 Top View of Hard Disks 1 and 2.

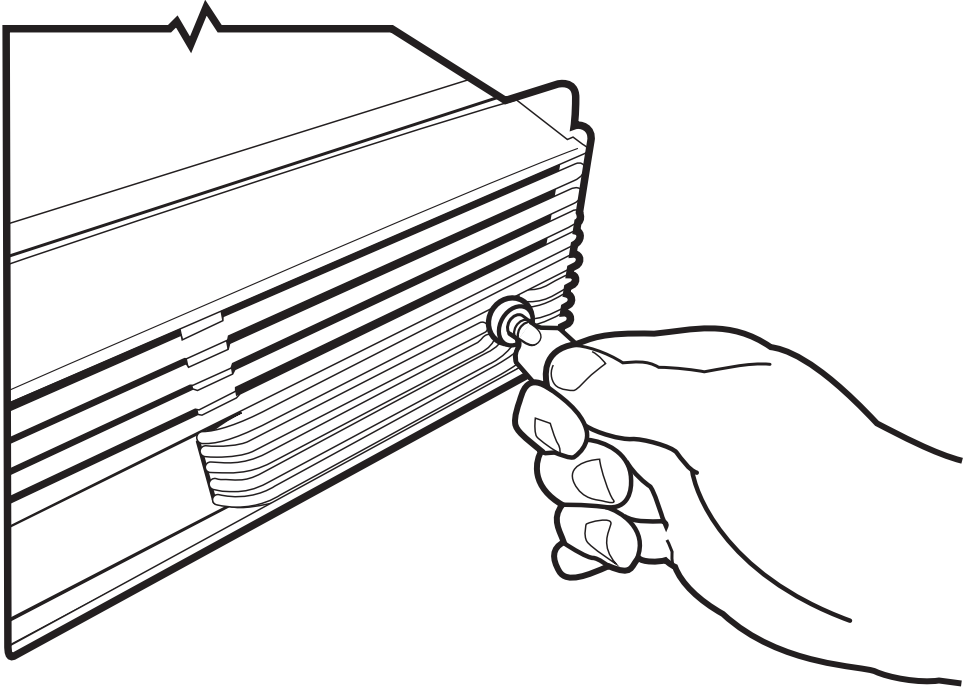

Figure 2.12 Unlocking the Front Bezel of the TMP6400-CTRL

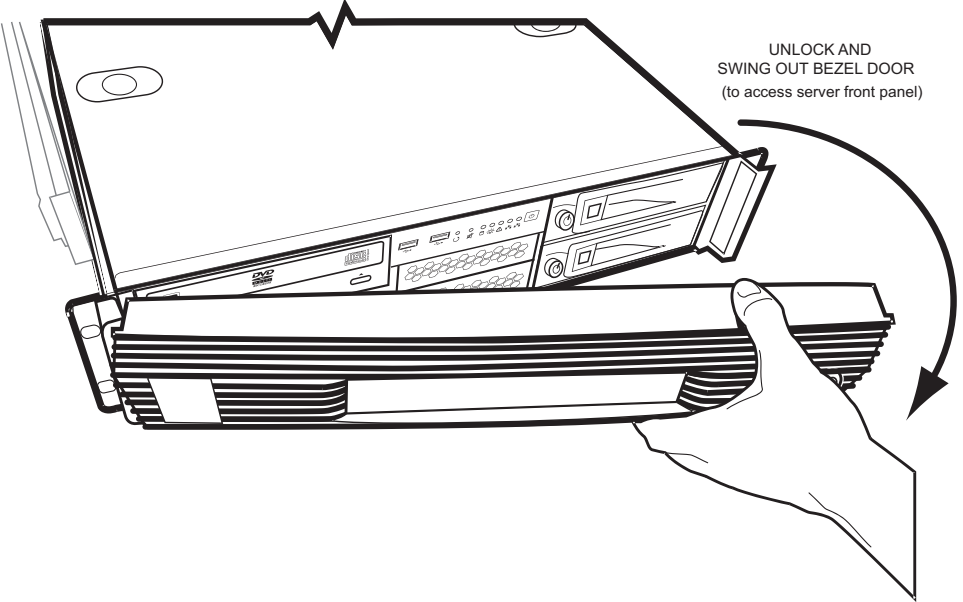

Figure 2.13 Opening the Front Bezel to Access the Hard Disks of the TMP6400-CTRL

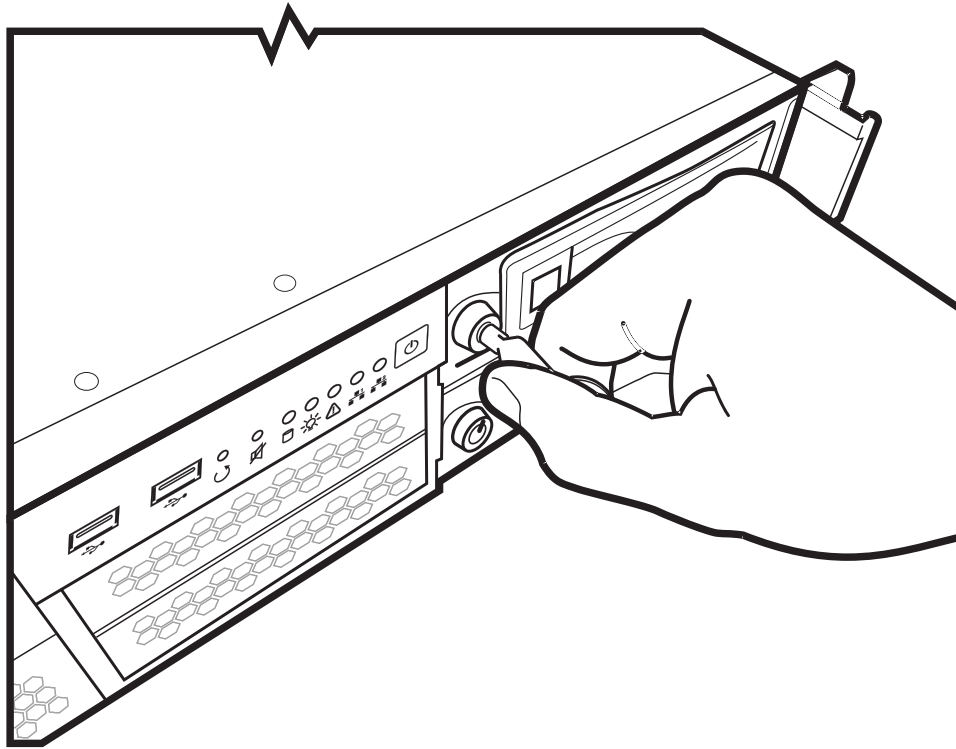

Figure 2.14 Unlocking the Hard Disk Door

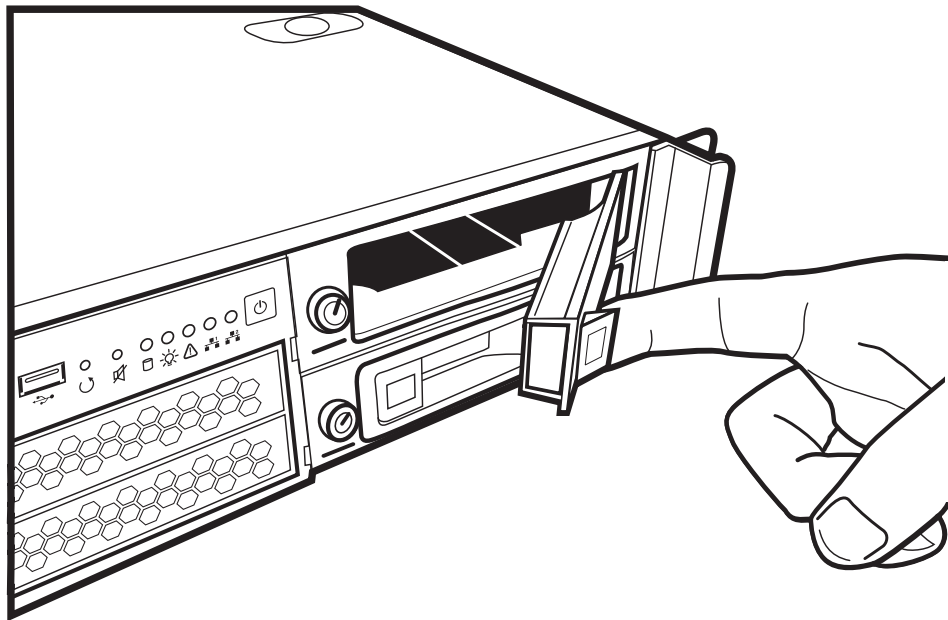

Figure 2.15 Opening the Hard Disk

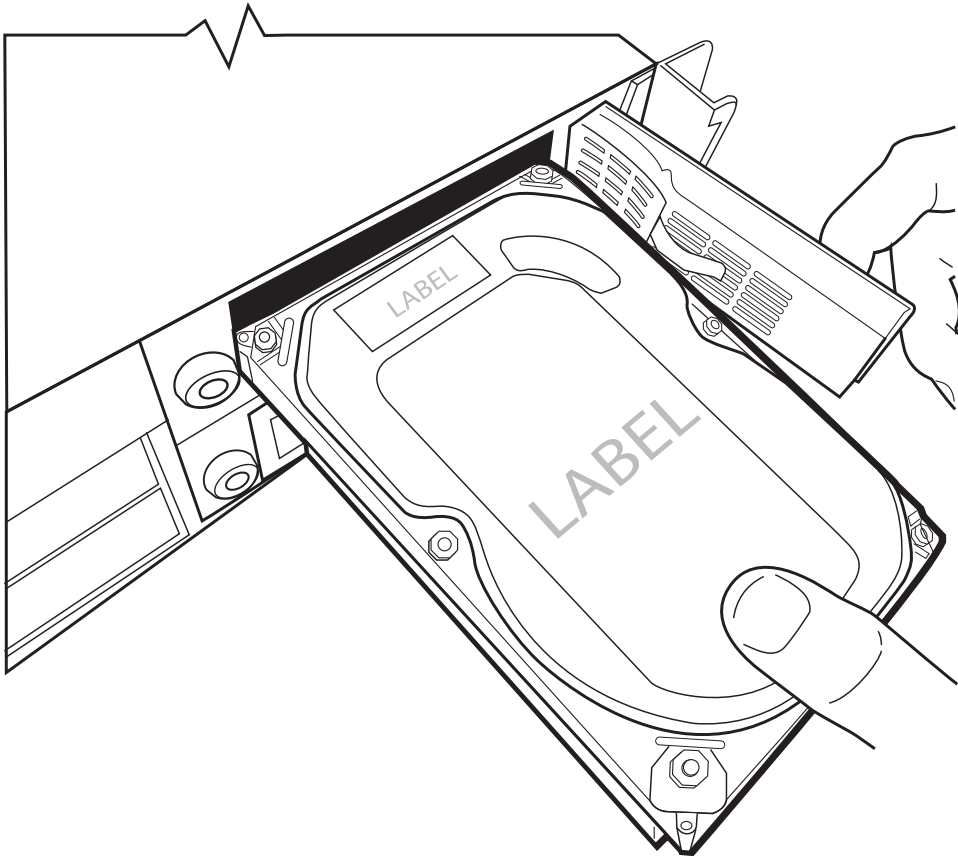

Figure 2.16 Inserting the Hard Disk

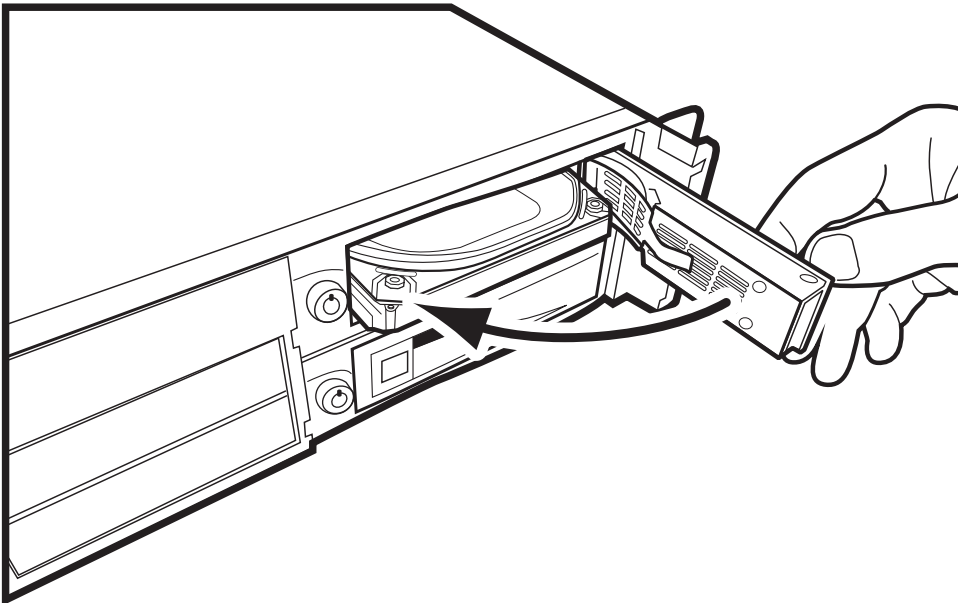

Figure 2.17 Closing the Hard Disk Door

2.2.3.2 TMP6400 Telecom Units

Mounting the TMP6400 Telecom Unit(s):

1. Using four metal screws, attach one angle bracket to the front, left-hand side of the TMP6400 Telecom Unit, when viewed from the front. Do the same for the angle bracket on the right-hand side.
2. Start mounting equipment beneath the TMP6400-CTRL, keeping in mind the space required on the equipment rack as described in Section 2.2.2 “Vertical Placement of Tdev TMP6400 Development Platform Equipment” on page 11.
3. Repeat steps 1 and 2 for each additional TMP6400 Telecom Unit.

Note If you are installing TMP6400-TE units you will require one (1) to two (2) patch panels per TMP6400-TE. Mount the patch panels beneath each TMP6400-TE.

2.2.3.3 TMP6400-TMS

Mounting the TMP6400-TMS Unit(s):

1. Using four metal screws, attach one angle bracket to the front, left-hand side of the TMP6400-TMS, when viewed from the front. Do the same for the angle bracket on the right-hand side.
2. Start mounting equipment beneath the last TMP6400 Telecom Unit, keeping in mind the space required on the equipment rack as described in Section 2.2.2 “Vertical Placement of Tdev TMP6400 Development Platform Equipment” on page 11.
3. Repeat steps 1 and 2 for a second TMP6400-TMS.

2.3 TMP6400-CTRL

This section covers the following procedures:

- Section 2.3.1 “Connecting to the System Management Interface” on page 24.
- Section 2.3.2 “Connecting to the Tmedia Control Network” on page 25.
- Section 2.3.3 “Powering Up” on page 26.
- Section 2.6 “Start Up” on page 44.

2.3.1 Connecting to the System Management Interface

The Tmedia Management Interface enables administrators to perform management tasks on a TMP6400-CTRL.

Prerequisites

To communicate with the Tmedia Management Interface, the following is needed:

- One CAT5 Ethernet cable with RJ45 male-male terminations.

Note Ethernet cables are not supplied with the TMP6400-CTRL.

To communicate with the Tmedia Management Interface:

1. Connect an RJ45 cable from the TMP6400-CTRL to a Gigabit Ethernet switch.

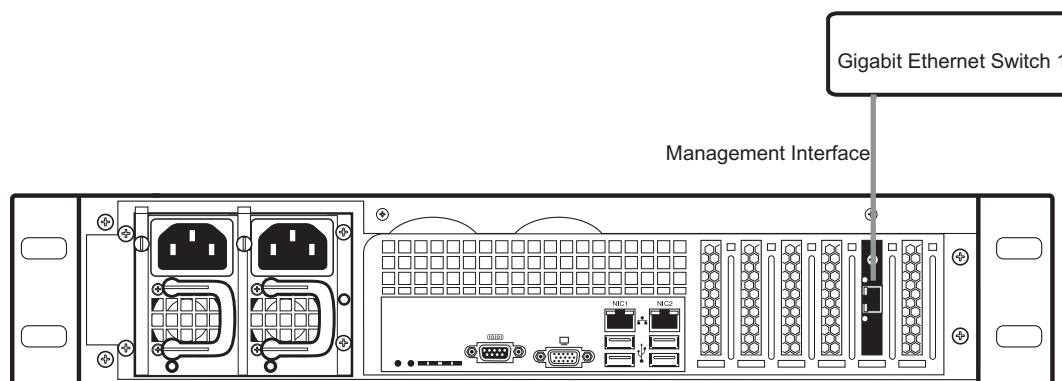

Figure 2.18 TMP6400-CTRL System Management Interface

2.3.2 Connecting to the Tmedia Control Network

The Tmedia Control network enables communication between the TMP6400-CTRL, the TMP6400 Telecom Unit(s), and the TMP6400-TMS.

Prerequisites

To connect the TMP6400 to the Tmedia control network, you will need:

- Two CAT5 Ethernet cables with RJ45 male-male terminations.

Connections

The TMP6400-CTRL is connected to the Tmedia control network using two CAT5 Ethernet cables, as shown in figure 2.22 on page 29.

To connect to the Tmedia control network:

1. Connect the NIC1 connector on the TMP6400-CTRL to the Tmedia Control network switch one.
2. Connect the NIC2 connector on the TMP6400-CTRL to the Tmedia Control network switch two.

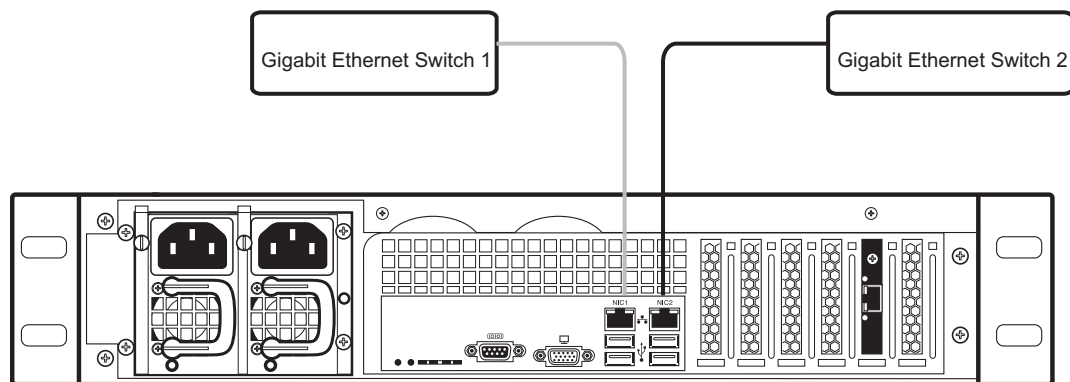

Figure 2.19 Connecting to the Tmedia Control Network

2.3.3 Powering Up

The TMP6400-CTRL is furnished with two (2) AC or two (2) DC power connections. Only once all other equipment installation work has been completed should the Tdev Development Platform be powered up.

Prerequisites

To power the TMP6400-CTRL, you will need:

- Two independent AC or DC power sources.
- Two power cables.

2.3.3.1 Connecting to AC Power

The TMP6400-CTRL is furnished with two AC power connectors.

To connect the TMP6400-CTRL to AC Power:

1. Connect the first power connector of the TMP6400-CTRL to the first power source. See Figure 2.20.
2. Connect the second power connector of the TMP6400-CTRL to the second power source.

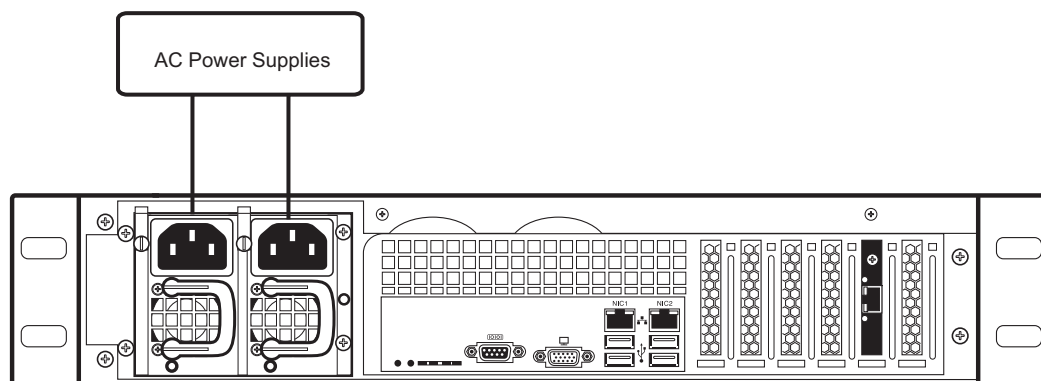

Figure 2.20 TMP6400-CTRL AC Power Connections

2.3.3.2 Connecting to DC Power

The TMP6400-CTRL is furnished with two DC power connection ports. In addition, each DC powered TMP6400-CTRL is supplied with two DC power cables.

To connect the TMP6400-CTRL to DC Power

1. Connect the first DC power connector of the TMP6400-CTRL to DC power source one. See figure 2.21 on page 27.
 - 1a. Connect one lead of each DC power cable to the positive terminal of the DC power source.
 - 1b. Connect the other lead of each DC power cable to the negative side of the DC power source.
2. Repeat the previous steps for DC power source two.

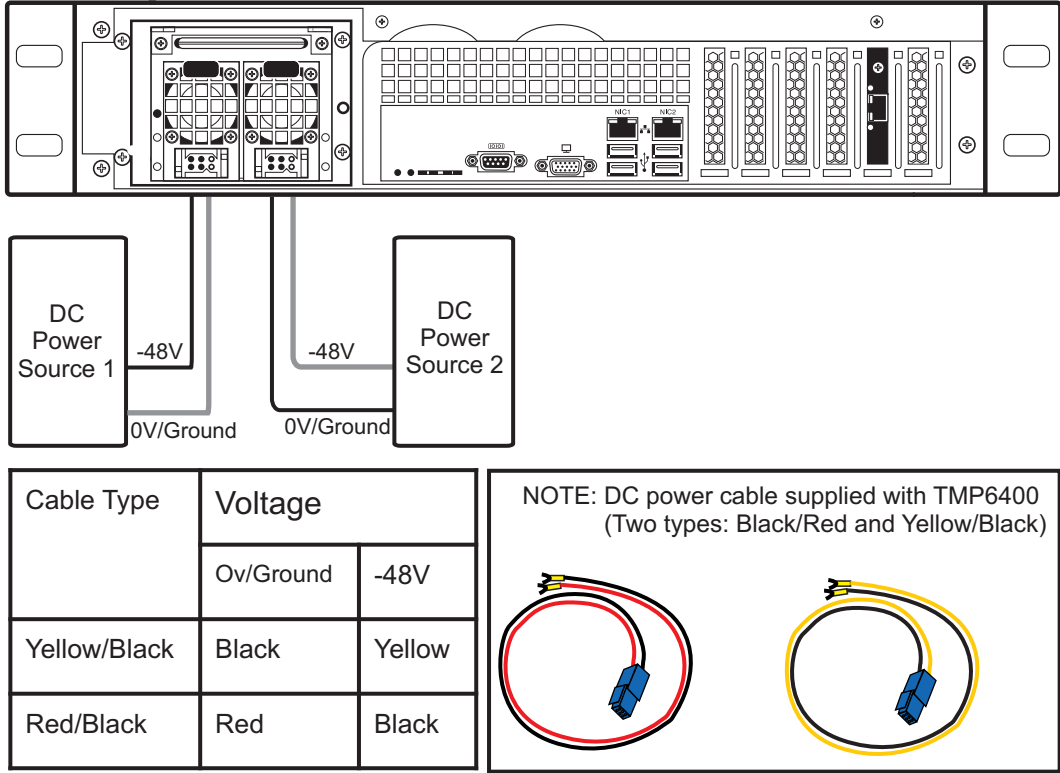

Figure 2.21 TMP6400-CTRL DC Power Connections

2.4 TMP6400 Telecom Unit

This section covers the following procedures:

- Section 2.4.1 “Connecting to the Tmedia Control Network” on page 29.
- Section 2.4.2 “Connecting to the VoIP Network(s)” on page 30.
- Section 2.4.3 “Connecting to the PSTN” on page 31.
- Section 2.4.4 “Connecting to the TMS Network” on page 36.
- Section 2.4.5 “Powering Up” on page 39.

2.4.1 Connecting to the Tmedia Control Network

The Tmedia Control network enables communication between the TMP6400-CTRL, the TMP6400 Telecom Unit(s), and the TMP6400-TMS.

Prerequisites

To connect the TMP6400 Telecom Unit(s), you will need:

- Two CAT5 Ethernet cables with RJ45 male-male terminations for each TMP6400 Telecom Unit.

Connections

The TMP6400 Telecom Unit(s) are connected to the Tmedia control network using two CAT5 Ethernet cables, as shown in figure 2.22 on page 29.

To connect to the Tmedia control network:

1. Connect the ETH0 connector on the TMP6400 Telecom Unit to the Tmedia Control network switch one.
2. Connect the ETH1 connector on the TMP6400 Telecom Unit to the Tmedia Control network switch one.
3. Repeat steps 1 and 2 for each additional TMP6400 Telecom Unit.

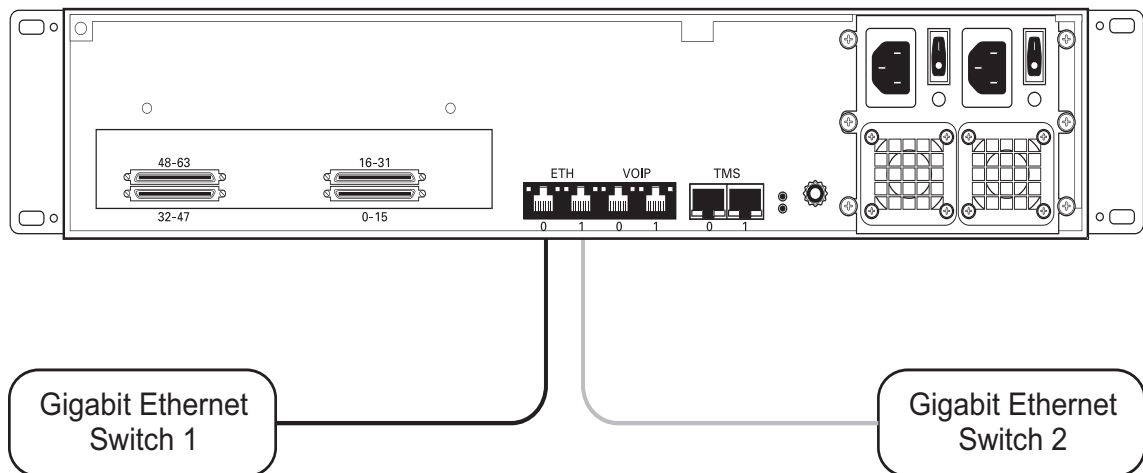

Figure 2.22 Connecting to the Tmedia Control Network

2.4.2 Connecting to the VoIP Network(s)

Each TMP6400 Telecom Unit features dual GigE ports for connection to different VoIP networks. This provides an access point to manage VoIP traffic. Should one of the IP networks fail, the TMP6400 Telecom Units will continue to manage VoIP traffic using the alternate network.

The IP address of the VoIP ports can be modified using the web portal.

Note: The TMP6400 Telecom Units require two (2) gigabit layer 2 Ethernet switches.

Prerequisites

To connect the TMP6400 Telecom Units to the VoIP network, you will need:

- Two gigabit layer 2 Ethernet switches. A second one is required to support redundancy of the VoIP interface.
- Two CAT5 Ethernet cables with RJ45 male-male terminations.
- Two IP addresses located on different subnets.

Connections

The TMP6400 Telecom Units are connected to the VoIP network through two Ethernet GigE network links, as shown in figure 2.23 on page 30.

To connect to the VoIP network:

1. Connect the VoIP0 connector from each TMP6400 Telecom Unit to the first Ethernet switch.
2. Connect the VoIP1 connector from each TMP6400 Telecom Unit to the second Ethernet switch.

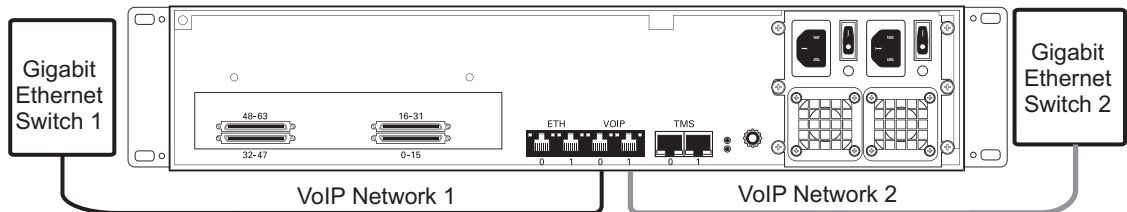

Figure 2.23 Connecting to the VoIP Network

2.4.3 Connecting to the PSTN

The TMP6400 Telecom Units feature a variety of interfaces to the PSTN network.

Prerequisites

To connect the TMP6400 Telecom Unit to the PSTN network, you must comply with one of the following:

- Your TMP6400-TE features SCSI connectors for connection to T1/E1 lines. You will require one patch panel for each 32 line grouping of T1/E1 line interfaces with 2 SCSI cables per patch panel (supplied). Each T1/E1 line interfaces requires a RJ48C to connect to the PSTN (not supplied).
- Your TMP6400-DS3 features BNC connectors for connection to DS3 lines. You will require two coaxial cables for each DS3 interface.
- Your TMP6400-STM1 features electrical or optical STM-1 connectors. You will require two fibre optic cables for each STM-1 interface.

2.4.3.1 SCSI Interface (T1/E1) for the TMP6400-TE

A TMP6400-TE with 4 SCSI connectors enables the connection to T1/E1 lines. The termination impedance is set at 120 ohms. It is possible to connect an external balun in order to convert to 75 ohms.

Note All ports may not be active. T1/E1 ports are activated by software license; the number of active ports depends on the licenses purchased.

Patch panels use straight connections. In other words, they do not cross the RX and TX signals. Connections between the patch panels and the TMP6400 require straight cables. The supplied SCSI cables are straight cables. Cables used to connect the network to the patch panel must do the cross connection.

To connect the TMP6400-TE to the PSTN:

1. Start with SCSI ports 0-15 located at the bottom right as shown in figure 2.24 on page 33. Connect one SCSI cable between this port and SCSI patch panel number 1, ports 0-15. Connect SCSI ports 16-31 to patch panel number 1, ports 16-31.
2. Repeat step 1, using lines 32-63 and a second patch panel. Connect lines 32-47 to patch panel 2, ports 0-15. Connect lines 48-63 to patch panel 2, ports 16-31.

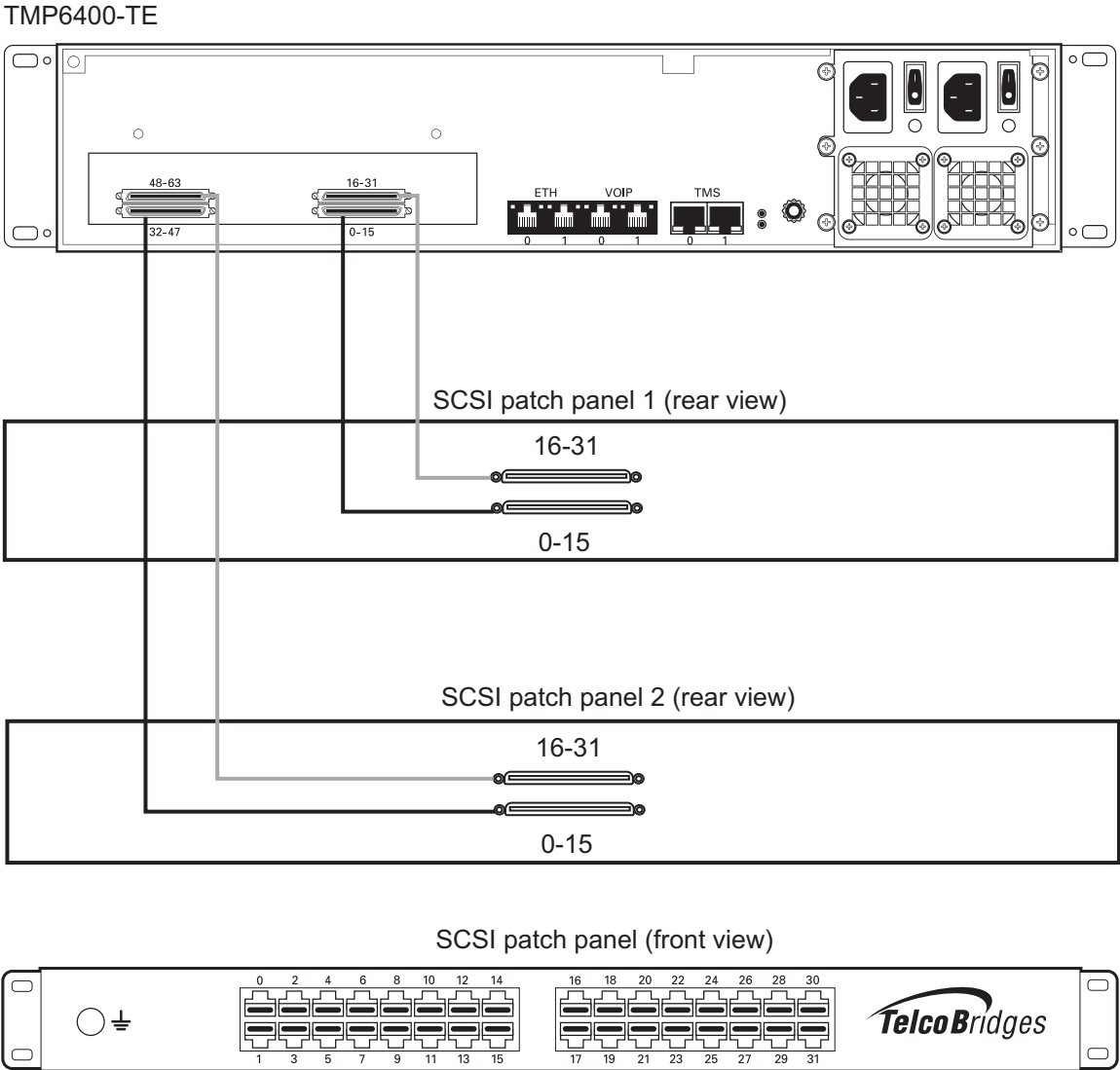

Figure 2.24 TMP6400 with SCSI connectors

2.4.3.2 Dual BNC Interface (DS3) for the TMP6400-DS3

A TMP6400-DS3 with 3 sets of BNC connectors enables the connection to DS3 lines. See figure 2.25 on page 34.

Note All ports may not be active. DS3 ports are activated by software license; the number of active ports depends on the licenses purchased.

To connect the TMP6400-DS3 to the PSTN:

1. Start with the Dual BNC port pair #0 (right-most) as shown in figure 2.25 on page 34. Connect one pair of BNC cables between this port and the DS3 line.
2. Repeat step 1, using the next available pair of BNC PSTN interface ports.

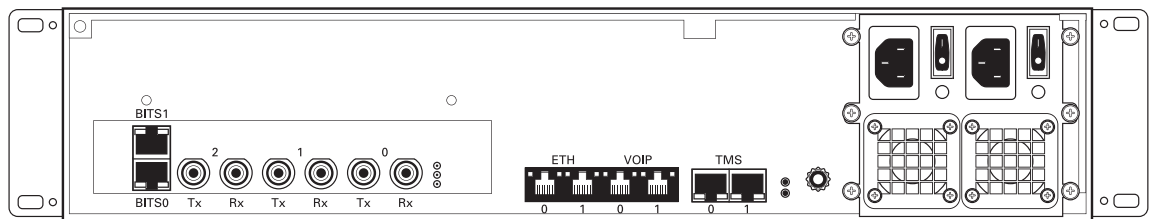

Figure 2.25 DS3 Interface to the PSTN

Note The (TMP6400-DS3 / TMP6400-STM1) features 2 Bits interfaces that can be used to synchronize the TDM network. It is recommended that you connect the Bits interface to the bits port of the TMP6400-TMS, if there is one installed in your system.

2.4.3.3 Optical Interface (OC3/STM-1) for the TMP6400-STM1

A TMP6400-STM-1, with one main and one backup OC3 or STM1 port enables connection to OC3/STM1 lines. See figure 2.26 on page 35. Refer to table 2.2 on page 35 for a listing of optical interfaces. The default SFP module for OC3/STM1 connection is SMF, intermediate reach, (SFP-OC3-IR1) 1310 nm with LC type connectors.

Note Please make certain that the correct SFP model is selected at the time of ordering. If your installation requires a different model from the one that has been provided, you must replace it.

Table 2.2 Optical Interfaces

Transceiver Model	Description	Spec	Mode	Type	Range (Km.)	Wavelength (NM)	Connection
SFP-OC3-IR1	OC3/STM1	Hot Pluggable	Single-mode	Intermediate reach	15	1310	LC
SFP-STM1E	STM1E (Electrical)	Hot Pluggable	75 ohms Cooper	Max 180m	1	NA	DIN (mini-coax)

Automatic Protection Switching

The APS port is used for OC3/STM1 redundancy. Switchover occurs automatically based on configurable parameters. It is recommended that APS be used if the installation provides this feature.

To connect the TMP6400-STM1 (Optical Interface) to the PSTN:

1. Connect a fiber optic cable between the Port 0 (Main) port and OC3/STM1 line, as shown in figure 2.26 on page 35.
2. Connect a fiber optic cable between the Port 1 (APS) port and OC3/STM1 line.

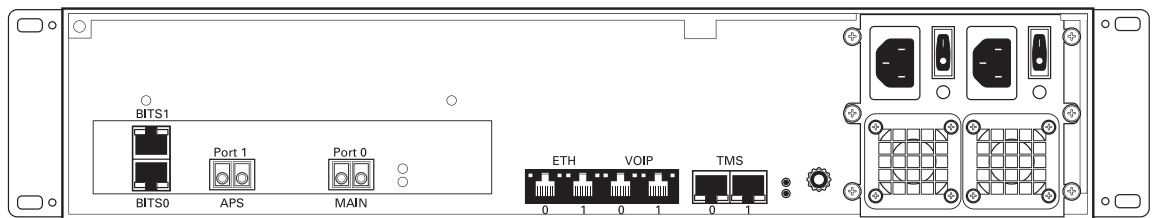

Figure 2.26 Optical Interface to the PSTN

Note The (TMP6400-DS3 / TMP6400-STM1) features 2 Bits interfaces that can be used to synchronize the TDM network. It is recommended that you connect the Bits interface to the bits port of the TMP6400-TMS, if there is one installed in your system.

2.4.4 Connecting to the TMS Network

Note Each connection from a TMP6400 Telecom Unit to the TMS network requires one CAT7 shielded ethernet crossover cable with RJ45 type male-male connectors.

2.4.4.1 Connecting to the TMP6400 Telecom Units

The TMP6400-TMS enables you to scale your system by interfacing as many as 16 TMP6400 Telecom Units with the TMP6400-TMS Switch network, building a non-blocking system of up to 32,768 channels. A second TMP6400-TMS provides your system with an active/standby high availability architecture.

Prerequisites

To interconnect the TMP6400 Telecom Units with the TMP6400-TMS, you will need:

- One CAT7 shielded Ethernet crossover cable with RJ45 type male-male terminations for each TMP6400 Telecom Unit connected to the TMG700-TMS.
- If your system features a second TMP6400-TMS, you will require an additional CAT7 shielded Ethernet cable with RJ45 male-male terminations for each TMP6400 Telecom Unit.

Interconnections

See figure 2.29 on page 38 for an Ethernet crossover wiring diagram.

To interconnect the TMP6400-TMS:

1. Start with the TMP6400 Telecom Unit at the topmost position of the equipment rack and connect a CAT7 shielded Ethernet crossover cable to the TMS0 connector at the rear of the TMP6400 Telecom Unit, figure 2.27 on page 37. Connect the other end of the same CAT7 cable to the first port of the first TMP6400-TMS.

Note Ensure that the TMS0 port of each Telecom Unit connects to the same TMP6400-TMS switch.

2. If your system employs a second TMP6400-TMS, connect a second CAT7 shielded Ethernet crossover cable to TMS1 at the rear of the TMP6400 Telecom Unit, figure 2.27 on page 37. Connect the other end of the same CAT7 cable to the first port of a second TMP6400-TMS.

Note Ensure that the TMS1 port of each Telecom Unit connects to the same TMP6400-TMS switch.

3. Repeat steps 1-2 for each TMP6400 Telecom Unit until they have all been connected to the TMP6400-TMS.

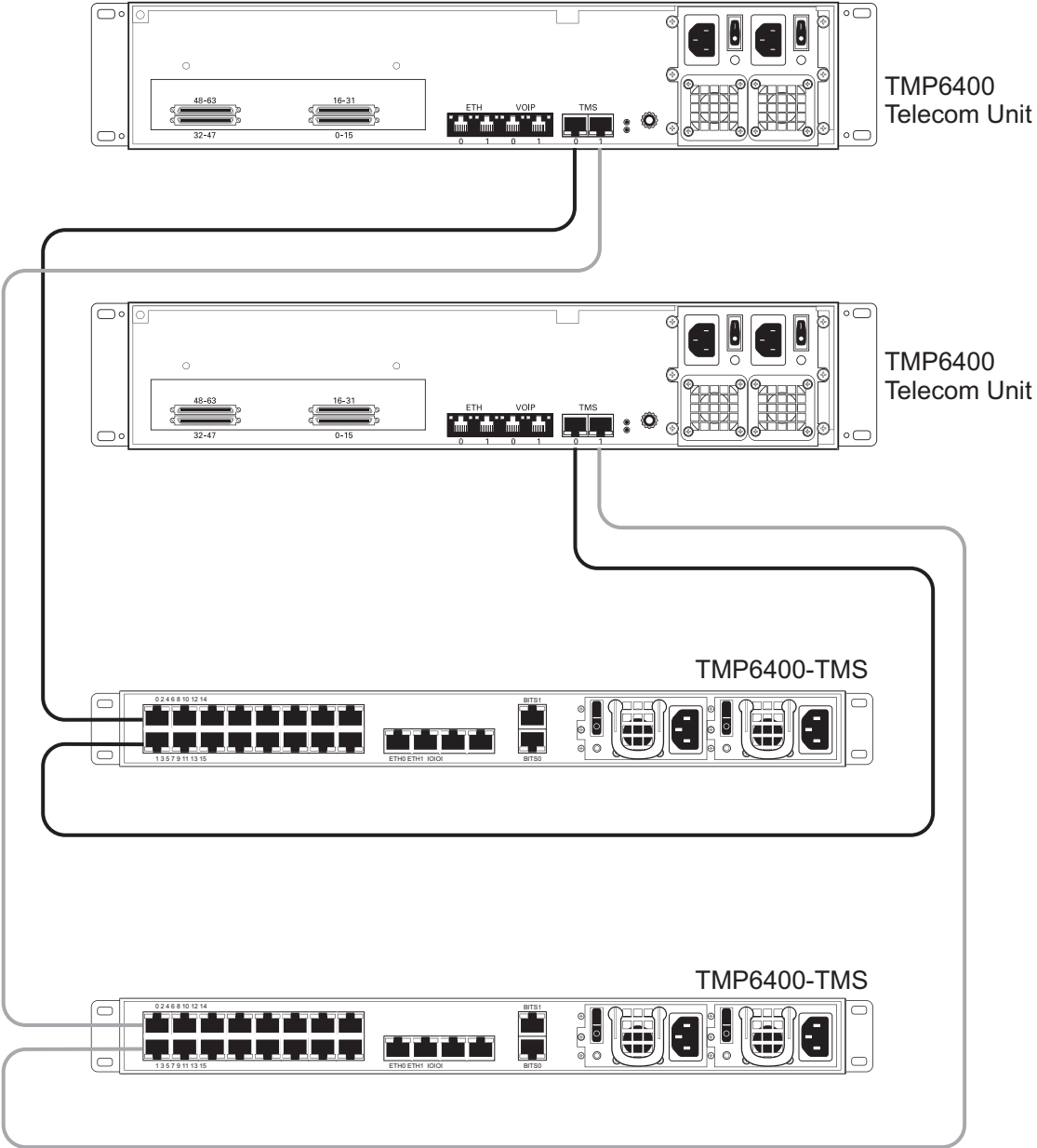

Figure 2.27 Example of Interconnecting 2 TMP6400 Telecom Units to an active and standby TMP6400-TMS

2.4.4.2 Interconnecting Two TMP6400 Telecom Units

If your TMP6400 Development Platform has no more that two TMP6400 Telecom Units, they can be connected to each other without the use of a TMP6400-TMS switch.

Simply connect the TMS0 ports of each unit together using a CAT7 shielded cross-over cable with RJ45 male-male terminations. Do the same for the TMS1 ports of each unit. See figure 2.28 on page 38.

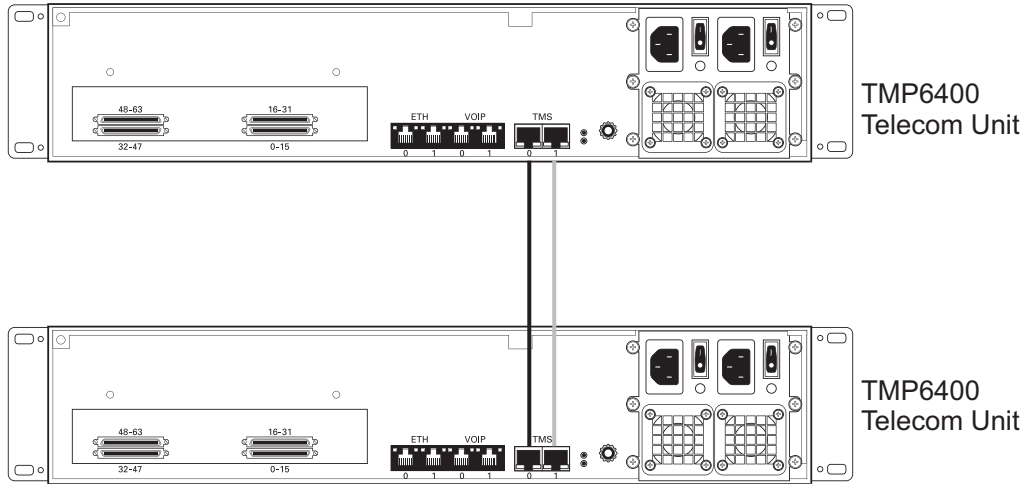

Figure 2.28 Interconnecting two TMP6400 Telecom Units.

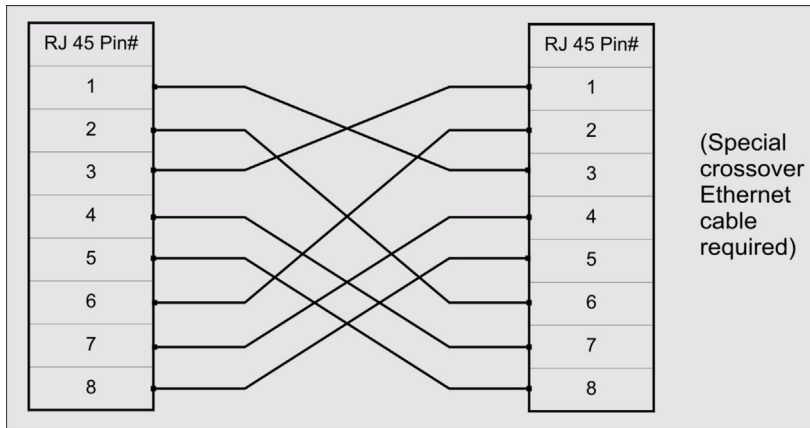

Figure 2.29 Ethernet Crossover Cable

2.4.5 Powering Up

The TMP6400 Telecom Units are furnished with two AC or DC power connections. Only once all other equipment installation work has been completed should the TMP6400 Telecom Unit be powered up.

2.4.5.1 Connecting to AC Power

Prerequisites

To power the TMP6400 Telecom Unit, you will need:

- One to two power sources.
- Two power cables.

The TMP6400 Telecom Unit AC model is furnished with two AC power connectors.

To connect the TMP6400 Telecom Unit to AC Power:

1. Connect an AC power cable between the AC connector of the TMP6400 Telecom Unit and an AC supply. See figure 2.30 on page 39.

Note If the TMP6400 Telecom Unit features a second power supply and it is not connected to an AC power source, press the green button located at the rear of the unit to disable the audible alarm. See figure 2.30 on page 39.

2. Power up the TMP6400 Telecom Unit by turning on its power switch(es).

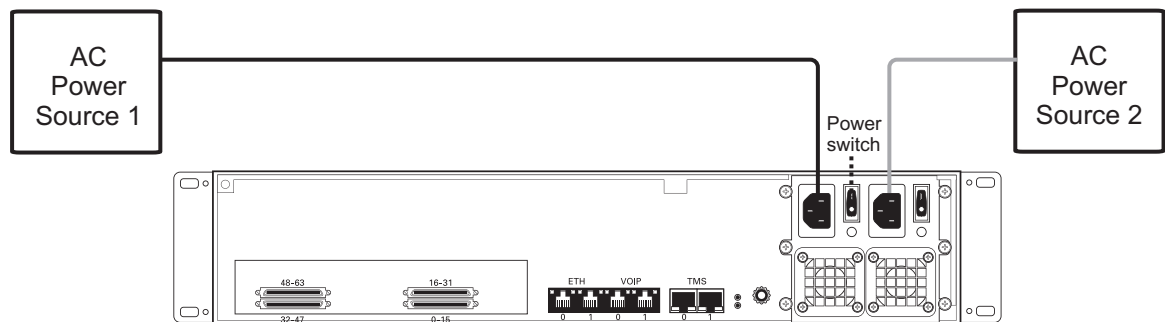

Figure 2.30 AC Power Connection

2.4.5.2 Connecting to DC Power

The TMP6400 Telecom Unit DC model is furnished with two DC power connection ports. In addition, each DC powered TMP6400 Telecom Unit is supplied with two DC power cables.

To connect the TMP6400 Telecom Unit to DC power:

1. Connect one DC cable, supplied with the TMP6400 Telecom Unit, as shown in figure 2.31 on page 40, to the DC outlet at the rear of the TMP6400 Telecom Unit.

Note Two types of cable with different coloring are available. Refer to figure 2.31 on page 40 for the appropriate wiring information.

2. Connect one lead of the DC power cable to the positive terminal of the DC power source.
3. Connect the other lead of the DC power cable to the negative side of the DC power source.
4. Repeat steps 1-3 for the second power DC power source.

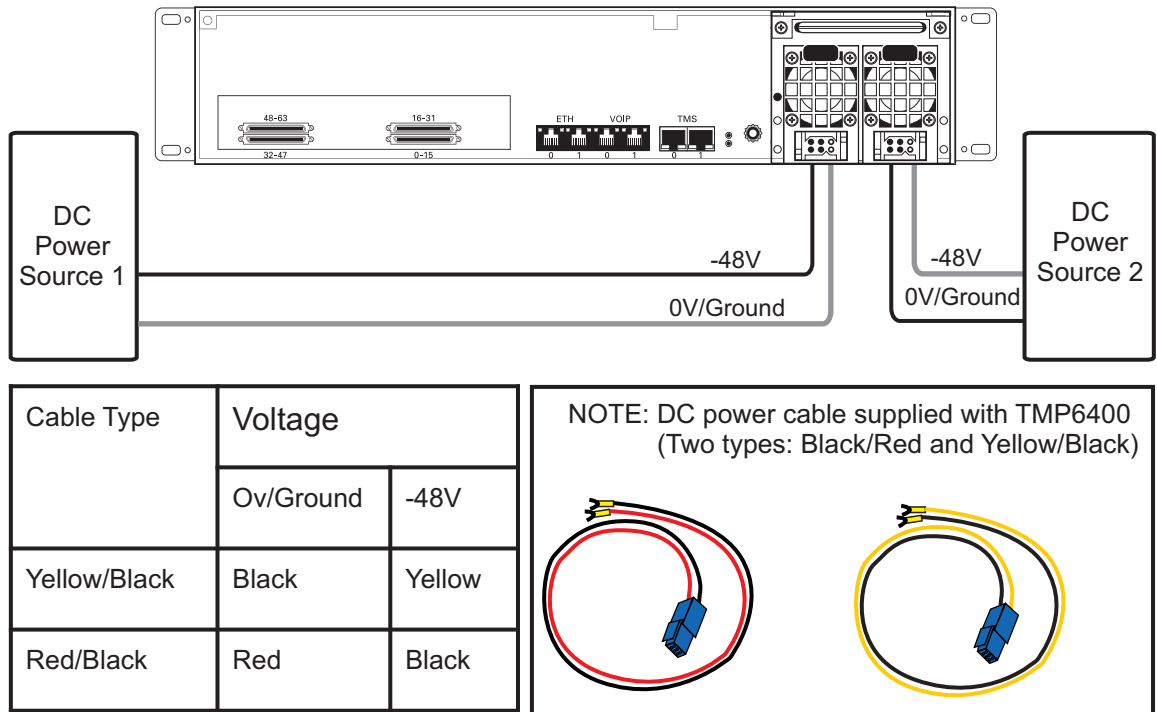

Figure 2.31 DC Power Connection

2.5 TMP6400-TMS

This section covers the following procedures:

- Section 2.5.1 “Connecting to the Tmedia Control Network” on page 41.
- Section 2.5.2 “Powering Up” on page 42.

2.5.1 Connecting to the Tmedia Control Network

The Tmedia Control network enables the communication between the TMP6400-CTRL, the TMP6400 Telecom Unit(s), and the TMP6400-TMS.

Prerequisites

To connect the TMP6400-TMS, you will need:

- Two CAT5 Ethernet cables with RJ45 male-male terminations.

Connections

The TMP6400-TMS is connected to the Tmedia control network using two CAT5 Ethernet cables, as shown in figure 2.22 on page 29.

To connect to the Tmedia control network:

1. Connect the ETH0 connector on the TMP6400-TMS to Tmedia Control network switch one.
2. Connect the ETH1 connector on the TMP6400-TMS to Tmedia Control network switch one.
3. Repeat step 1 and 2 for a second TMP6400-TMS.

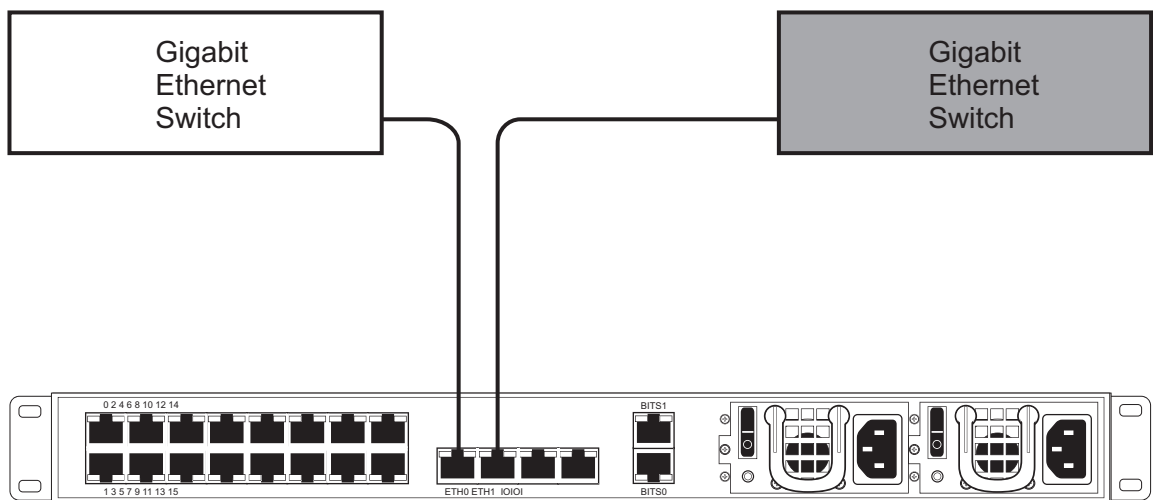

(Left=1, Right=2)

Figure 2.32 Connecting to the Tmedia Control Network

2.5.2 Powering Up

The TMP6400-TMS is with two (2) AC or two (2) DC power connections. Only once all other equipment installation work has been completed should the TMP6400-TMS be powered up.

Prerequisites

To power the TMP6400-TMS, you will need:

- Two independent AC power sources.
- Two power cables for each TMP6400-TMS.

2.5.2.1 Connecting to AC Power

The TMP6400-TMS AC models are furnished with two AC power connectors.

To connect the TMP6400-TMS to AC Power:

1. Connect the first power connector of each unit to the first power source. See Figure 2.33.
2. Connect the second power connector of each unit to the second power source.

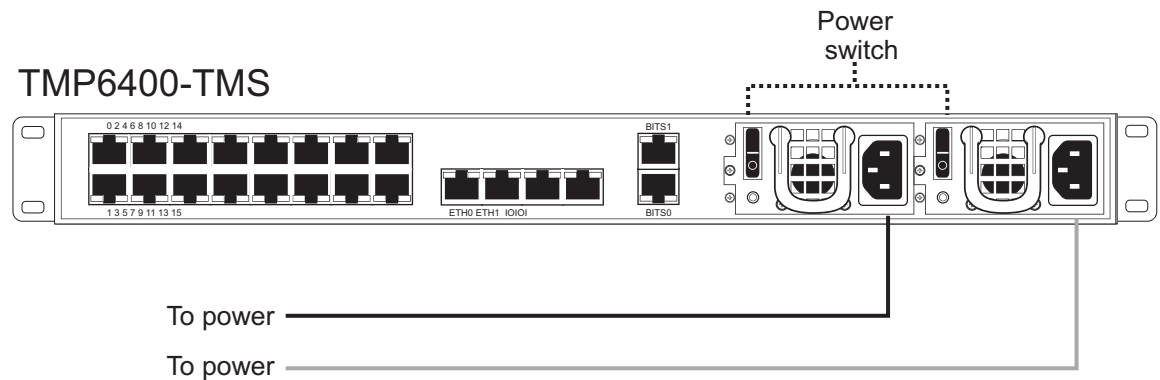

Figure 2.33 AC Power Connections

2.5.2.2 Connecting to DC Power

The TMP6400-TMS DC models are furnished with two DC power connection ports.

To connect the TMP6400-TMS to DC power:

1. Connect a ground wire to the ground lug located at the rear of the TMP6400-TMS, as shown in figure 2.34 on page 43.
2. Connect a 14 AWG wire between the positive terminal of a DC power source and the terminal on the TMP6400-TMS labelled \oplus .
3. Connect a 14 AWG wire between the negative terminal of a DC power source and the terminal on the TMP6400-TMS labelled 48V.
4. Repeat steps 1-3 for the second DC power source.
5. Turn on the DC power source.

TMP6400-TMS

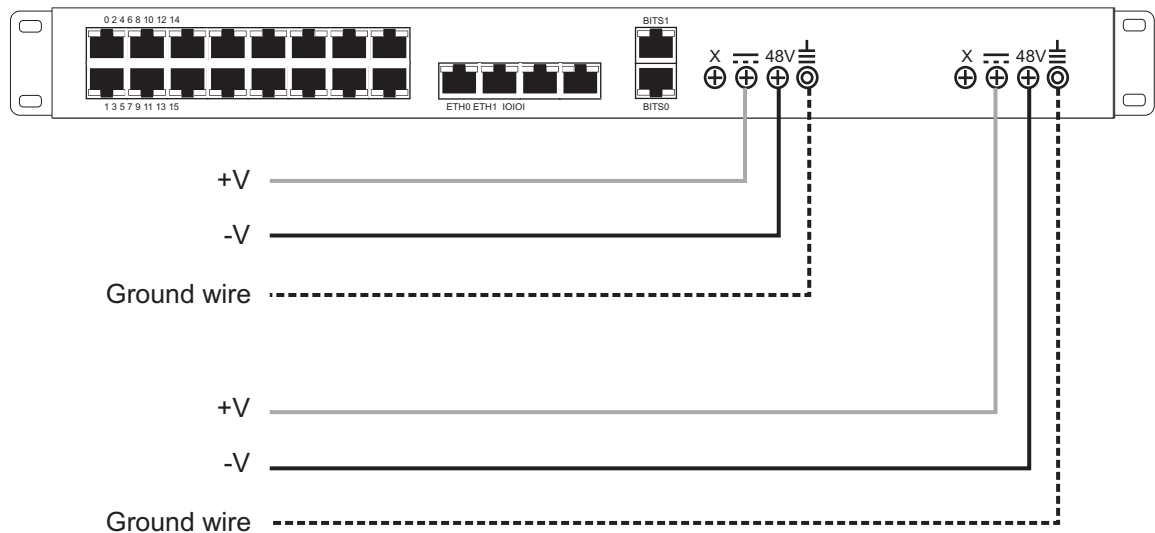

Figure 2.34 DC wiring diagram

2.5.3 TDM System Clock

The TMP6400 system must be synchronized with the TDM network. This can be done in several ways:

- Synchronized with an incoming trunk
- Synchronized with a SONET SDH
- Synchronized with a BITS port

If your system features a TMP6400-TMS and a BITS interface is available, it is recommended that the BITS interface be connected to the BITS port of the TMP6400-TMS.

2.6 Start Up

After powering up the TMP6400-CTRL, you must select one of the servers to be the primary server. If you have a second server, configure it as a secondary.

Once these configuration settings have been applied, your Tdev TMP6400 Development Platform will start up and display the web portal configuration management tool.

2.6.1 Primary

1. Connect to the web portal. The Welcome page appears.

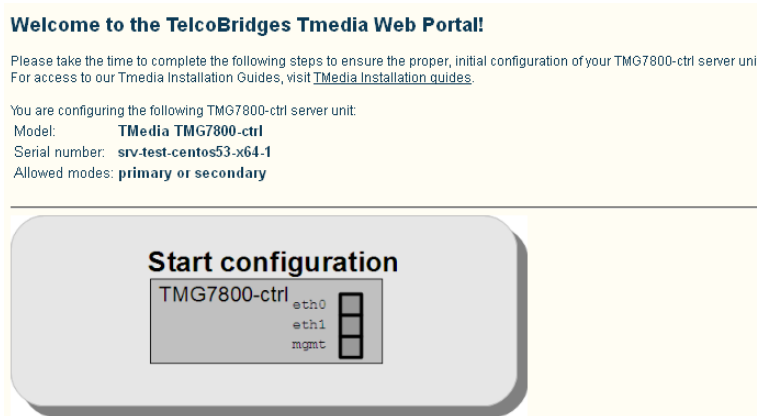

Note: The Welcome page indicates whether the TMP6400-CTRL is a primary or secondary unit.

2. Select the top portion of the image to configure the TMP6400-CTRL as a primary unit.

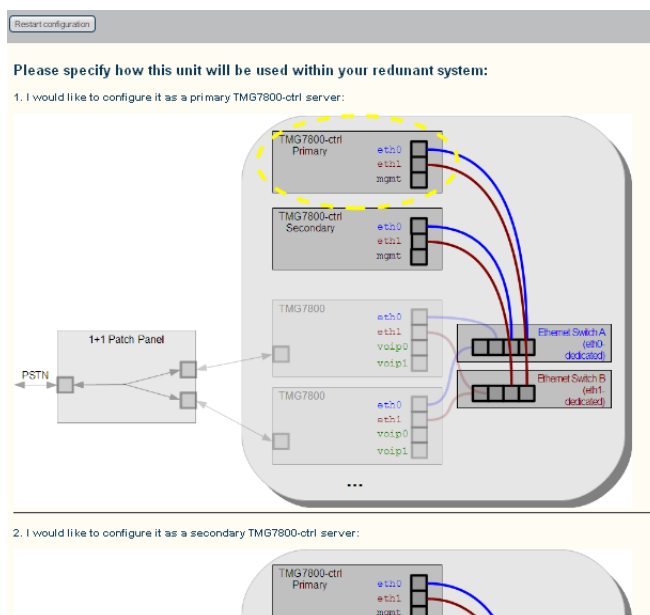

3. Select New Redundant.

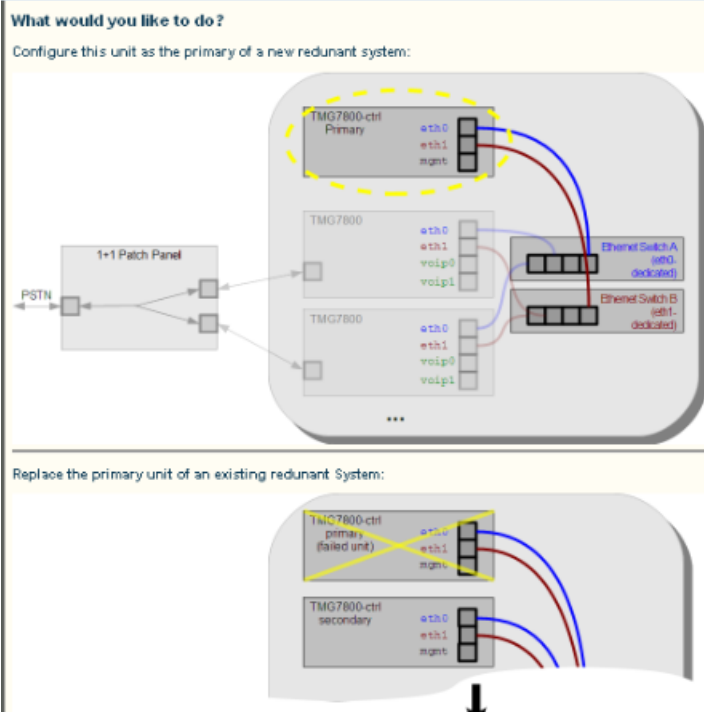

4. Before clicking the **Yes, it's connected like that already**, verify that the physical connections have been properly done.

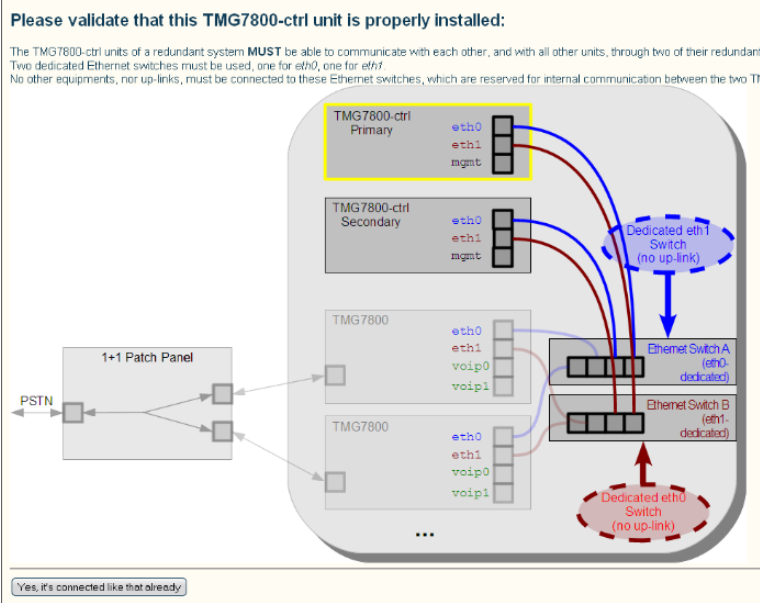

2.6.2 Secondary

1. Connect to the web portal. The Welcome page appears.

Welcome to the TelcoBridges Tmedia Web Portal!

Please take the time to complete the following steps to ensure the proper, initial configuration of your TMG7800-ctrl server unit. For access to our Tmedia Installation Guides, visit [Tmedia Installation guides](#).

You are configuring the following TMG7800-ctrl server unit:

Model: **TMedia TMG7800-ctrl**

Serial number: **svr.test.centos53-x64-1**

Allowed modes: **primary or secondary**

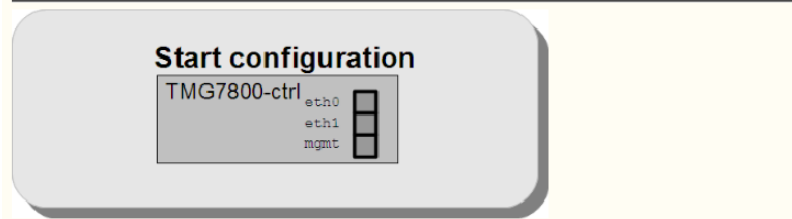

Note: The Welcome page indicates whether the TMP6400-CTRL is a primary or secondary unit.

- 2. Select the bottom portion of the image to configure the TMP6400-CTRL as a secondary unit.

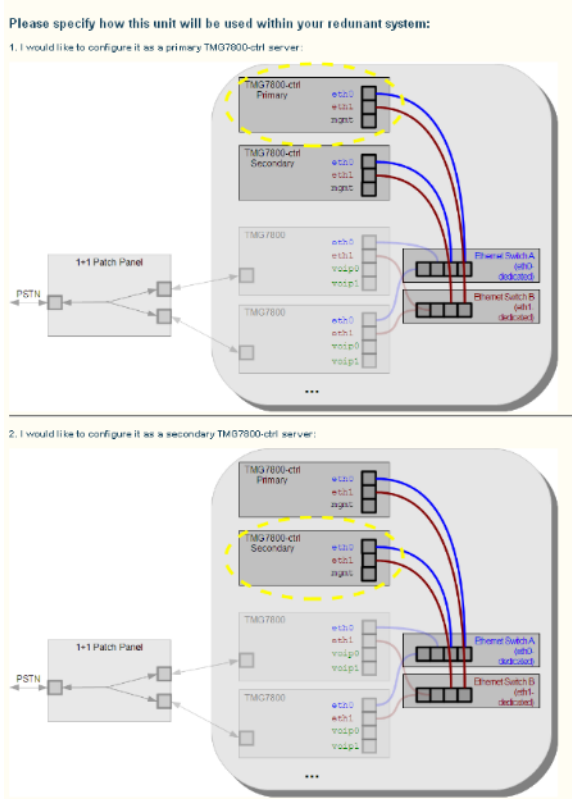

- 3. Before clicking the **Yes, it's connected like that already**, verify that the physical connections have been properly done.

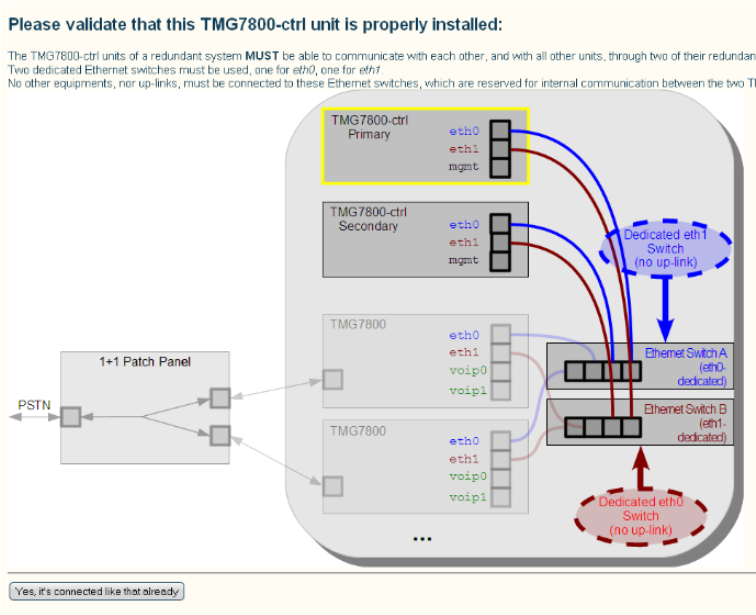

Yes, it's connected like that already.

2.7 Verifying the LED Status Indications

When the Tdev Development Platform has been powered up, verify the front panel of each unit to determine that all indications are normal.

2.7.1 TMP6400-CTRL

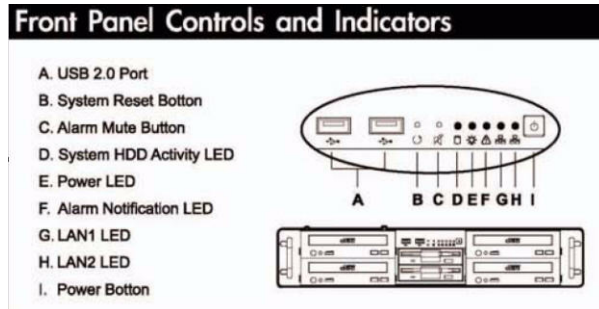

Table 2.3 TMP6400-CTRL Indicators

Display Order	Display
System HDD Activity LED (yellow)	Indicates the operation of the hard drive: <ul style="list-style-type: none"> • Blinking = active • No light = inactive
Power LED (blue)	<ul style="list-style-type: none"> • On = powered • Off = unpowered
Alarm Notification LED (red)	<ul style="list-style-type: none"> • On = stem error • Off = no alarm
LAN 1 LED (green)	<ul style="list-style-type: none"> • On = LAN is busy • Off = no connection
LAN 2 LED (green)	<ul style="list-style-type: none"> • On = LAN is busy • Off = no connection

2.7.2 TMP6400 Telecom Unit

Once the TMP6400 Telecom Unit has run successfully through its system boot procedures, the following will be displayed in an alternating fashion as described in table 2.4 on page 48:

Table 2.4 TMP6400 Telecom Unit Displays

Display Order	Display
First Screen	IP 0: <ip address of eth0. E.g. 192.168.0.2> IP 1: <ip address of eth1 E.g. 192.168.0.3>

Display Order	Display
Second Screen	<board type. eg. TMP-STM1, TMS-16, TMP-DS3, TMP-16, TMP-32, TMP-64> <adapter name e.g. TB002821> <serial number e.g. TB002821> <release used e.g V2.2.0 RC1>

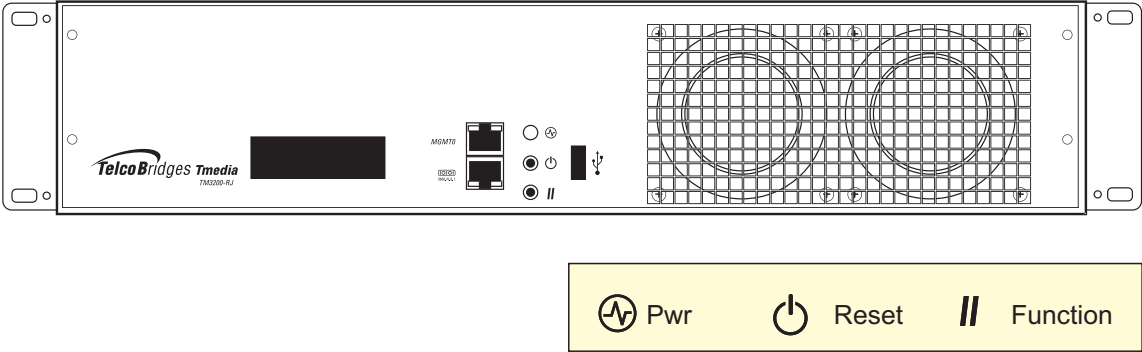

Figure 2.35 Front display and LEDs

If the reset button is pressed a software menu will appear on the display at the front of the unit. Press the function button to select one of the two actions listed in table 2.5 on page 49. Once your selection is made, press the reset button to acknowledge your choice.

Table 2.5 Reset Menu Options

Menu Choices	Description
M Options:	
e >Shutdown	Graceful shutdown of the Tdev Development Platform. This takes a few minutes. Press the reset button to restart the Tdev Development Platform.
n Rst telecom	Reboots the telecom platform of the Tdev Development Platform.

2.7.3 TMP6400-TMS

Once the TMP6400-TMS has run successfully through its system boot procedures, the following will be displayed in an alternating fashion as described in table 2.4 on page 48:

Table 2.6 TMP6400-TMS Displays

Display Order	Display
First Screen	Toolpack controlled from host <serial number>
Second Screen	Serial <Serial number> IP <eth0 ip>/<eth1 ip>

When pressing the reset button, the following will appear (it is only possible to restart, no shutdown option available):

```
Reset?
>Yes
  No
```

Select with the function button, the press the reset button again to apply the change.

2.8 Powering Down

2.8.1 TMP6400-CTRL

Powering down the Tdev Development Platform requires that the Linux embedded host be shut down. In order to do this, you must connect to the management interface using SSH, and enter:

```
shutdown -hP now
```

Attention DO NOT TURN OFF the power to the Tdev Development Platform system using the power switch located at the rear, unless the Linux host has been properly shut down beforehand, instead use the reset button display, or manually use the shutdown command.

Allow enough time for the Linux host to shut down before turning off the power to the Tdev Development Platform (ex. 1 minute). Be aware that the shutdown procedure of the unit is logged and traceable for support and warranty purposes.

Note As an alternate method to this procedure, refer to Section 2.7 “Verifying the LED Status Indications” on page 48, to power down the Tdev Development Platform with the reset button.

2.8.2 TMP6400 Telecom Unit

Unplug the power cord from the unit. The unit can be restarted using restart button on the front of the unit.

2.8.3 TMP6400-TMS

Unplug the power cord from the unit. The unit can be restarted using restart button on the front of the unit.

Chapter 3 Initial System Configuration

This chapter provides information about the following topics:

- Section 3.1.1 “Connecting to the Serial Port of the TMP6400-CTRL”
- Section 3.2 “Configuring the Terminal Emulator Application”
- Section 3.3 “Connecting to the Tdev Development Platform”
- Section 3.4 “Retrieving Tdev Development Platform Information”
- Section 3.5 “Changing the Tdev Development Platform Management Port IP Address”
- Section 3.5 “Changing the Tdev Development Platform Management Port IP Address”
- Section 3.7 “Setting the Time Zone”
- Section 3.8 “Configuring the Tdev Development Platform Using the Web Portal”
- Section 3.9 “Changing VoIP Interface Addresses”

3.1 Connecting to the Serial Port of the Tdev Development Platform

The connection to the serial port of the Tdev Development Platform is comprised of the following procedures:

- Connecting to the Serial Port of the TMP6400-CTRL
- Connecting to the Serial Port of the TMP6400 Telecom Unit

3.1.1 Connecting to the Serial Port of the TMP6400-CTRL

Note By default, the management port is set to DHCP.

Sections 3.1 and 3.2 provide instructions on how to convert the DHCP management port to a static IP address. If your network supports DHCP, skip sections 3.1 and 3.2.

The serial port interface enables administrators to perform management tasks on the Tdev Development Platform. You can connect to the serial port of a Tdev Development Platform, using one of the following two methods.

Method 1: Use a male-male DB9 cross-connect cable

1. Connect a male-male DB9 cross-connect cable between the DB9 serial port of your computer and the DB9 serial port of the TMP6400-CTRL. See figure 3.1 on page 54.

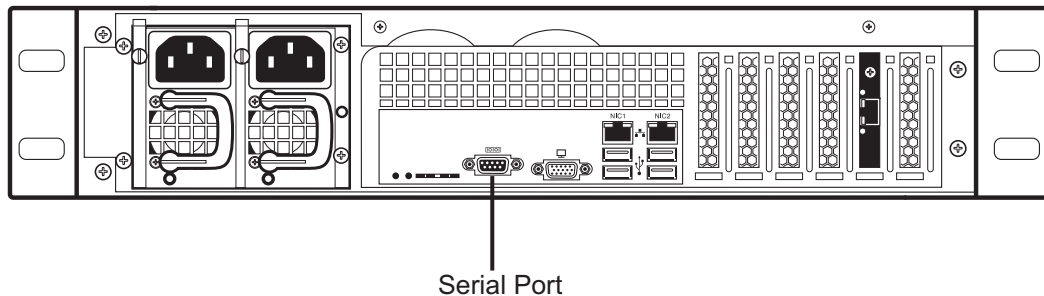

Figure 3.1 Tdev Development Platform Serial Port Connection

Method 2: Use a USB to DB9 adapter

1. Connect the USB connector of the cable to a USB port on your computer and the DB9 connector of the cable to the DB9 serial port of the TMP6400-CTRL. See figure 3.2 on page 55.



Figure 3.2 USB to DB9 Adapter

3.1.2 Connecting to the Serial Port of the TMP6400 Telecom Unit

The serial port interface enables administrators to perform management tasks on the TMP6400 Telecom Unit.

To connect to the serial port of a TMP6400 Telecom Unit:

1. Connect a CAT5 RJ-45 (male-male) cable (supplied with unit) between the com port of your computer and the serial port (labelled 10101) of the TMP6400 Telecom Unit as shown in figure 3.3 on page 55. See Section A.2 on page 63 for a RJ-45 console wiring diagram.
2. If your computer's serial port features a DB9 connector, use the DB9 to RJ-45 adapter supplied with your TMP6400 Telecom Unit. If your computer's serial port features a USB connector, you will need to provide a USB to DB9 adaptor. Refer to figure 3.2 on page 55.

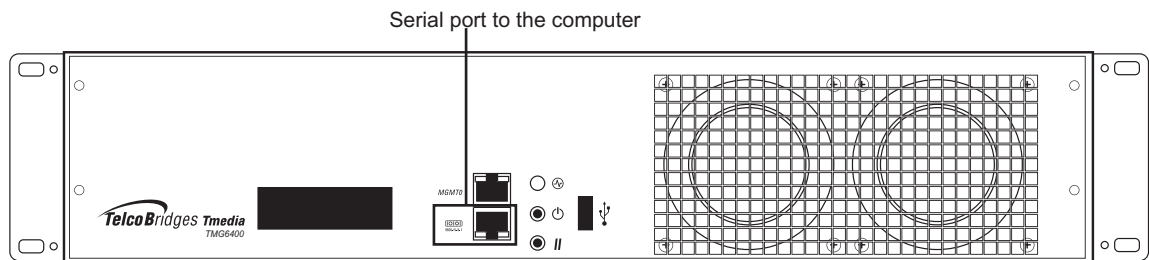

Figure 3.3 Computer to TMP6400 Telecom Unit Serial Port Connection

3.2 Configuring the Terminal Emulator Application

Before initiating communication with the Tmedia serial interface, you must first configure a terminal emulator or console application to communicate with the Tdev Development Platform in order to configure initial settings. Available terminal emulation software includes:

- HyperTerminal
- Putty
- Minicom

To configure the terminal emulator application:

1. Set the baud rate (bits per second) to **9600**
2. Set the data rate to **8 bits**
3. Set the parity to **None**
4. Set the stop bits to **1**
5. Set the flow control to **None**

Note See Section 3.5 on page 57 to learn how to change the IP address of the MGMT0 port.

3.3 Connecting to the Tdev Development Platform

The Tdev Development Platform is shipped with the TMG-CTRL preinstalled. In order to make changes to the system configuration, you must connect the port labelled MGMT0 at the front of the Tdev Development Platform to a terminal.

To access the Tdev Development Platform, you must use an SSH connection. The password is set at the factory and is indicated on the shipment sheet.

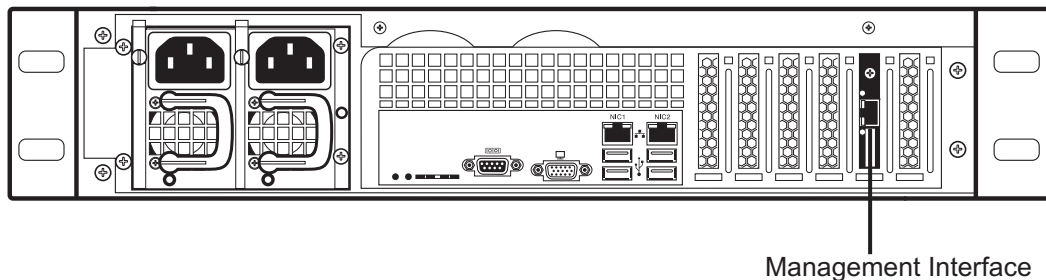

Figure 3.4 Tmedia Management Interface

3.4 Retrieving Tdev Development Platform Information

Note The Tdev Development Platform enables you to retrieve system information with the following shell commands:

- `tbproduct` (retrieve the Tmedia product type)
- `tbserial` (retrieve the Tmedia product type)

The Tdev Development Platform enables you to retrieve system information with the following shell commands:

- `tbproduct` (retrieve the Tmedia product type). See http://docs.telcobridges.com/mediawiki/index.php/TMG:Get_Product_Type, for further information.
- `tbserial` (retrieve the Tmedia serial number). See http://docs.telcobridges.com/mediawiki/index.php/TMG:Get_Serial_Number, for further information.

3.5 Changing the Tdev Development Platform Management Port IP Address

The management port of the Tdev Development Platform (labeled MGMT0) is configured using DHCP by default. It can be modified it using the following shell script:

- `tbchangeip`. See http://docs.telcobridges.com/mediawiki/index.php/TMG:Change_Management_IP_Address, for further information.

3.6 Changing Tdev Development Platform Management Port Passwords

Once logged you are logged on to the Tdev Development Platform, type “`passwd`”, to change the password being used. The following information will be displayed:

```
[root@TB003540 ~]# passwd

Changing password for user root.
New UNIX password:
Retype new UNIX password:
passwd: all authentication tokens updated successfully.
```

3.7 Setting the Time Zone

You can change the time zone of the Tdev Development Platform using the `tbtimezone` shell command.

3.8 Configuring the Tdev Development Platform Using the Web Portal

Note: The first time that you connect to the web portal, you will need to configure the role of the TMP6400-CTRL. See Section 2.6 “Start Up” on page 44

To change the default configuration of a Tdev Development Platform using the Web Portal, follow the steps described in the Web Portal System Configuration Tutorial Guide, found on the TBWiki:

<http://docs.telcobridges.com>

The Web Portal can be accessed with a Web browser. The default url is: `http://[Tmedia MGMT0 IP address]:12358`

Note If your system features two TMP6400-CTRL units, they can access the Web Portal from either one of their IP addresses.

The default login information to access the Web Portal application is:

- Username: root
- Password: root

3.9 Changing VoIP Interface Addresses

The default address of the VoIP interfaces of the Tdev Development Platform can be modified. To learn how this is done, refer to the Web Portal tutorial guide on the Telcobridges TB Wiki at docs.telcobridges.com.

Note With regard to sections 3.2, 3.3, 3.4 3.5, 3.6 or 3.7, please visit the TBWiki at: <http://docs.telcobridges.com>

Chapter 4 System Backups

This chapter provides information about the following topics:

- Section 4.1 “Creating a Database Backup”
- Section 4.2 “Downloading a Database Backup”
- Section 4.3 “Uploading a Database Backup”
- Section 4.4 “Restoring a Database Backup”

For more detailed information with regard to any of the points described in this section, please refer to the TBWiki: <http://docs.telcobridges.com>

4.1 Creating a Database Backup

It is important that backups be made of system configuration settings in the event of a system failure. It is recommended that a backup be made once the system has been configured. Backups are performed using the web portal.

4.2 Downloading a Database Backup

A backup of system data is stored on the hard drive of the Tdev Development Platform. It is important that system backups be downloaded to an external storage device.

4.3 Uploading a Database Backup

An external backup of your database can be uploaded to your Tdev Development Platform.

4.4 Restoring a Database Backup

In the event of a system failure requiring the replacement of a Tdev Development Platform, a previously saved backup of system settings can be restored to the new unit.

Appendix A Wiring Diagrams

A.1 RJ48C Wiring Diagram: Crossover and Straight Cables

RJ 48 (T1/E1/J1) Wiring Schematic: Crossover Cable

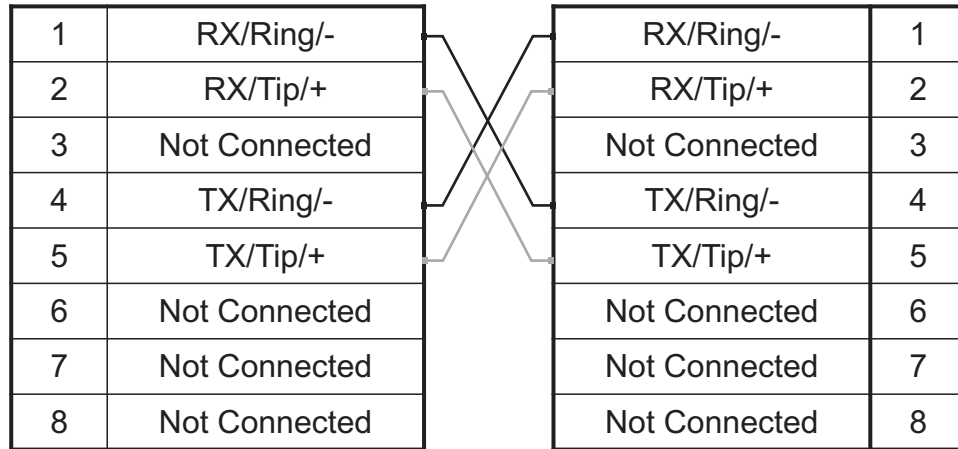

RJ 48 (T1/E1/J1) Wiring Schematic: Straight Cable

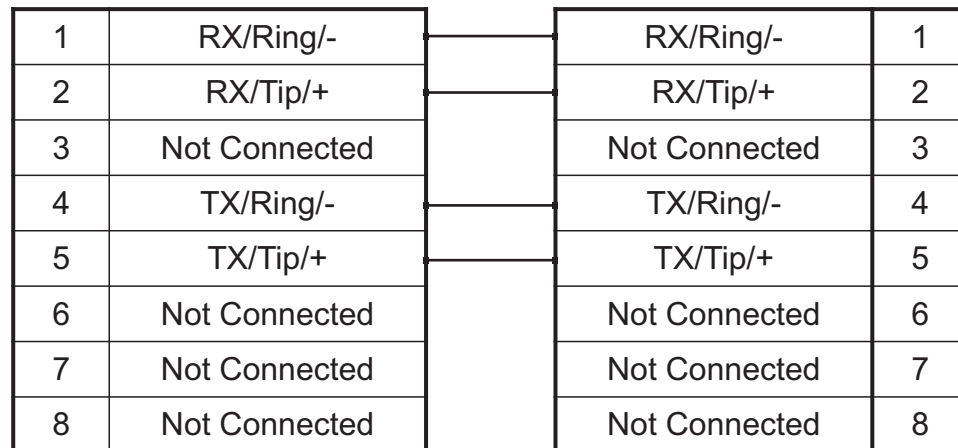

A.2 RJ48 Console Wiring Diagram

