

# **TMP800 Development Platform System Installation Guide**

Issue 2.0c

The information in this document as well as product specifications referred to throughout, are subject to change without notice. No part of this document may be reproduced or transmitted in any form or by any means, electronic or mechanical, for any purpose, without the express written permission of TelcoBridges. TelcoBridges may have patents or pending patent applications, trademarks, copyrights, or other intellectual property rights covering subject matter in this document. The furnishing of this document does not give you license to these patents, trademarks, copyrights, or other intellectual property except as expressly provided in any written license agreement from TelcoBridges Inc.

The information provided in this document is intended as a guide only. For the latest detailed engineering specifications, please contact TelcoBridges TB Support or visit the TBWiki: <http://docs.telcobridges.com>. TelcoBridges is committed to continually improving product designs; as a result, product specifications may be subject to change without notification.  
© 2003-2012 TelcoBridges. All rights reserved.

TelcoBridges, Tmedia, TMG800, TMG3200-RJ, TMG3200-TE, TMG3200-DS3, TMG3200-STM1, TMG7800-TE, TMG7800-DS3, TMG7800-STM1, TMG7800-CTRL, TMG-CONTROL, TMG7800-TMS, Tmedia 1+1, TMG800+1, TMG3200-RJ+1, TMG3200-TE+1, TMG3200-DS3+1, TMG3200-STM1+1, TMG7800-TE+1, TMG7800-DS3+1, TMG7800-STM1+1, Tdev, TMP800, TMP6400, TMP6400-CTRL, TMP6400-TMS, Tmonitor, TM1000, Toopack, Toolpack API, TB640, TB-8, TB-16, and TB-Video, are trademarks of TelcoBridges Inc. All other trademarks are the property of their owners. This information is subject to change without notice.

HEAD OFFICE  
TelcoBridges Inc.  
91 rue de la Barre, Suite 01  
Boucherville, QC, J4B 2X6  
CANADA  
[www.telcobridges.com](http://www.telcobridges.com)

T +1 450 655 8993  
F +1 450 655 9511  
[info@telcobridges.com](mailto:info@telcobridges.com)

TB Support -Technical Support  
Tel: +1 438 338 2100  
[support@telcobridges.com](mailto:support@telcobridges.com)  
[www.telcobridges.com/en/tbsupport.aspx](http://www.telcobridges.com/en/tbsupport.aspx)

# Preface

## About this Guide

This guide provides installation, and setup procedures for the Tdev TMP800 Development Platform.

## Conventions

| Terminology                      | Description   |
|----------------------------------|---|
| Tdev TMP800 Development Platform | This term is used when a description applies to the Tmedia system comprised of the TMP800-CTRL and TMP800 Telecom Unit. |
| TMP800-CTRL                      | This term is used when a description applies specifically to the TMP800-CTRL gateway controller.                        |
| TMP800 Telecom Unit              | This term is used when a description applies to the telecom unit of the TMP800 Development PlatformTMP800.              |

## Contact Us

If you have comments about this guide or any other TelcoBridges technical documentation, please send an email to [marketing@telcobridges.com](mailto:marketing@telcobridges.com).

# Table of Contents

|           |   |    |
|-----------|---|----|
| Chapter 1 | Introduction .....  | 1  |
| 1.1       | Identifying the Tdev TMP800 Development Platform Equipment.....           | 2  |
| 1.2       | Installation Prerequisites .....  | 3  |
| 1.2.1     | TMP800-CTRL .....   | 3  |
| 1.2.2     | TMP800 Telecom Unit .....   | 4  |
| 1.3       | Preventing Electrostatic Discharge Damage.....                            | 4  |
| 1.4       | Recommended Reading .....   | 5  |
| Chapter 2 | Installing the Equipment.....   | 7  |
| 2.1       | Package Contents.....   | 8  |
| 2.1.1     | TMP800-CTRL Gateway Controllers.....                                      | 8  |
| 2.1.2     | TMP800 Telecom Unit .....   | 9  |
| 2.2       | Rack Mounting the Tdev TMP800 Development Platform Equipment.....         | 10 |
| 2.2.1     | Prerequisites .....   | 10 |
| 2.2.2     | Vertical Placement of Tdev TMP800 Development Platform Equipment.....     | 10 |
| 2.2.3     | Installing the Tdev TMP800 Development Platform on an Equipment Rack..... | 11 |
| 2.2.3.1   | TMP800-CTRL .....   | 11 |
| 2.2.3.2   | TMP800 Telecom Units.....   | 21 |
| 2.3       | TMP800-CTRL .....   | 21 |
| 2.3.1     | Connecting to the System Management Interface .....                       | 22 |
| 2.3.2     | Connecting to the Tmedia Control Network .....                            | 23 |
| 2.3.3     | Powering Up.....  | 24 |
| 2.3.3.1   | Connecting to AC Power .....  | 24 |
| 2.3.3.2   | Connecting to DC Power.....   | 25 |
| 2.4       | TMP800 Telecom Unit .....   | 26 |
| 2.4.1     | Connecting to the Tmedia Control Network .....                            | 27 |
| 2.4.2     | Connecting to a VoIP Network .....  | 28 |
| 2.4.3     | Connecting to the PSTN .....  | 29 |
| 2.4.4     | Powering Up.....  | 30 |
| 2.4.4.1   | Connecting to AC Power .....  | 30 |
| 2.4.4.2   | Connecting to DC Power.....   | 31 |
| 2.5       | Start Up .....  | 33 |
| 2.5.1     | Primary.....  | 33 |
| 2.5.2     | Secondary .....   | 35 |
| 2.6       | Verifying the LED Status Indications .....                                | 37 |
| 2.6.1     | TMP800-CTRL .....   | 37 |
| 2.6.2     | TMP800 Telecom Unit .....   | 38 |
| 2.7       | Powering Down .....   | 39 |
| 2.7.1     | TMP800-CTRL .....   | 39 |
| 2.7.2     | TMP800 Telecom Unit .....   | 39 |
| Chapter 3 | Initial System Configuration .....  | 41 |
| 3.1       | Connecting to the Serial Port of the Tdev Development Platform.....       | 42 |
| 3.1.1     | Connecting to the Serial Port of the TMP800-CTRL .....                    | 42 |

|            |   |           |
|------------|---|-----------|
| 3.1.2      | Connecting to the Serial Port of the TMP800 Telecom Unit.....           | 43        |
| 3.2        | Configuring the Terminal Emulator Application .....                     | 44        |
| 3.3        | Connecting to the Tdev Development Platform.....                        | 44        |
| 3.4        | Retrieving Tdev Development Platform Information.....                   | 45        |
| 3.5        | Changing the Tdev Development Platform Management Port IP Address ..... | 45        |
| 3.6        | Changing Tdev Development Platform Management Port Passwords .....      | 45        |
| 3.7        | Setting the Time Zone.....  | 45        |
| 3.8        | Configuring the Tdev Development Platform Using the Web Portal .....    | 46        |
| 3.9        | Changing VoIP Interface Addresses .....                                 | 46        |
| Chapter 4  | <b>System Backups .....</b>   | <b>47</b> |
| 4.1        | Creating a Database Backup .....  | 48        |
| 4.2        | Downloading a Database Backup .....                                     | 48        |
| 4.3        | Uploading a Database Backup.....  | 48        |
| 4.4        | Restoring a Database Backup .....                                       | 48        |
| Appendix A | <b>Wiring Diagrams.....</b>   | <b>49</b> |
| A.1        | RJ48C Wiring Diagram: Crossover and Straight Cables.....                | 50        |
| A.2        | RJ48 Console Wiring Diagram .....                                       | 51        |

# Chapter 1 Introduction

This chapter provides an introduction to the installation and setup of a Tdev TMP800 Development Platform:

The following topics are covered:

- Section 1.1 “Identifying the Tdev TMP800 Development Platform Equipment”
- Section 1.2 “Installation Prerequisites”
- Section 1.3 “Preventing Electrostatic Discharge Damage”
- Section 1.4 “Recommended Reading”

## 1.1 Identifying the Tdev TMP800 Development Platform Equipment

The Tdev TMP800 Development Platform is comprised of the following equipment:

- One (1) or two (2) TMP800-CTRL gateway controller(s). See figure 1.1 on page 2.
- One TMP800 Telecom Unit. See figure 1.1 on page 2.

### TMP800-CTRL (outer view)

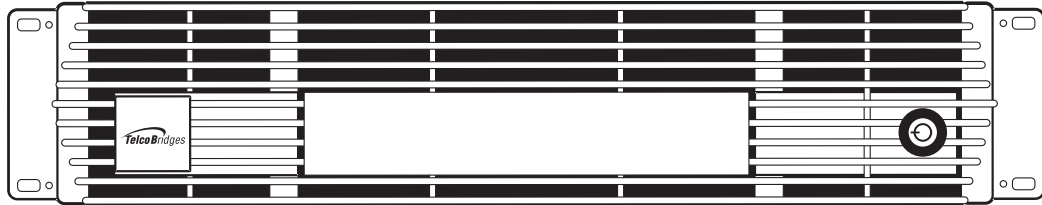

### TMP800-CTRL (inner view)

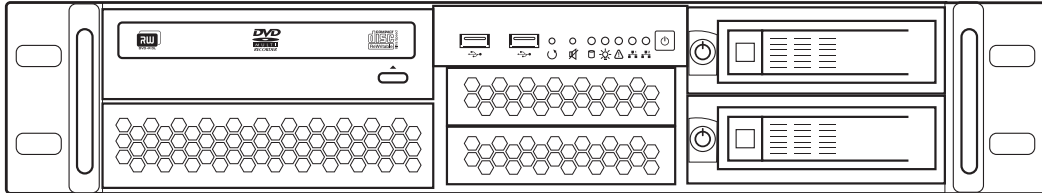

### TMP800-CTRL (rear view)

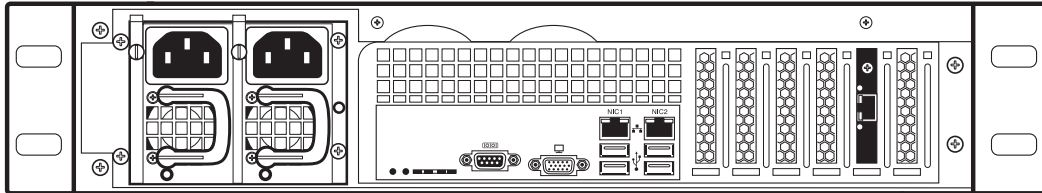

### TMP800 (front view)

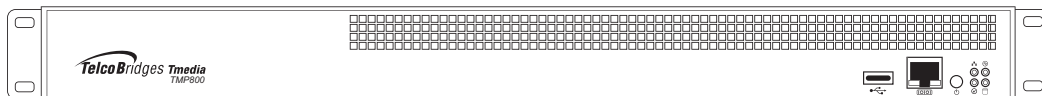

### TMP800 (rear view)



Figure 1.1 TMP800-CTRL and TMP800 Telecom Unit



## 1.2 Installation Prerequisites

For the installation to proceed without interruption, it is important that you verify that you have all necessary materials on hand.

### 1.2.1 TMP800-CTRL

#### Adequate space for the installation of the TMP800-CTRL

You will need to mount the TMP800-CTRL on a 19" equipment rack (customer provided). Your TMP800-CTRL is a 2U unit. Plan for an additional 2U space on the equipment rack for a redundant TMP800-CTRL.

**Note** The depth of the TMP800-CTRL is 26" (660mm) instead of 16" (406mm) depth of the TMP800 Telecom Units. It is important to plan for an equipment rack of an adequate size.

The dimension of the TMP800-CTRL are as follows:

- Depth x Width x Height (mm) 660 x 430 x 88
- Depth x Width x Height (inch) 26" x 16.9" x 3.5"

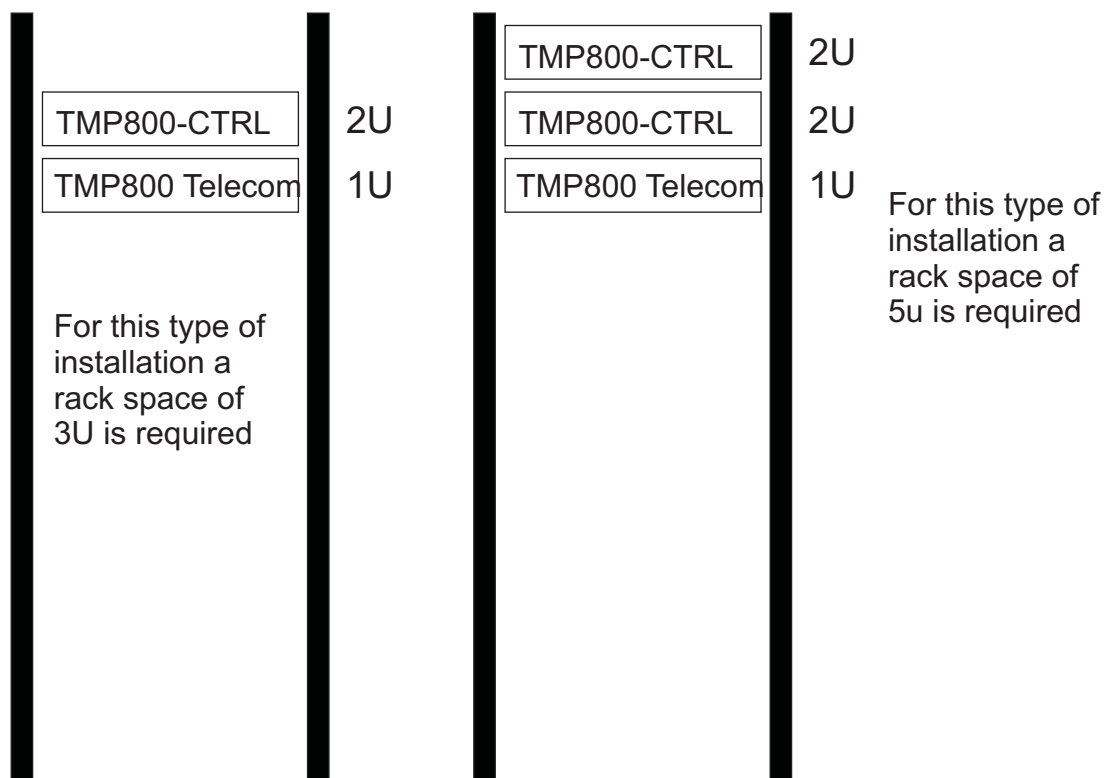

### **Adequate power supply and power connections**

Each TMP800-CTRL requires two power connections to provide for its redundant power supply. To guarantee an uninterrupted supply of electricity, each power connection must be fed by a dedicated power source.

### **An IP address for the management port**

Each TMP800-CTRL requires an IP address for the management port. To avoid delays, you should have the IP address, netmask and gateway addresses on hand. Take note that the management port supports DHCP, see Section 2.3.1 “Connecting to the System Management Interface” on page 22 for further information.

### **Cabling**

Three (3) customer supplied ethernet cables are required for each TMP800-CTRL to connect the TMP800-CTRL to the switches.

## **1.2.2 TMP800 Telecom Unit**

### **Adequate space for the installation of the TMP800 Telecom Unit**

You will need to mount the TMP800 Telecom Unit on a 19" equipment rack (customer provided). The TMP800 Telecom Unit is housed in a 1U chassis.

### **Adequate power supply and power connections**

The TMP800 Telecom Unit requires two power connections to provide for its redundant power supply.

To guarantee an uninterrupted supply of electricity, each power connection must be fed by a dedicated power source.

## **1.3 Preventing Electrostatic Discharge Damage**

Electrostatic discharge (ESD) can damage equipment and impair electrical circuitry. It may occur if electronic printed circuit cards are improperly handled and may cause complete or intermittent failure.



Warning

Always follow ESD prevention procedures when removing and replacing modules:

- Ensure that the Tdev Development Platforms are grounded.
  - Wear an ESD-preventive wrist strap and ensure that it makes good contact with your skin. Connect the wrist strap clip to an unpainted surface of the Tdev Development Platform or the grounded equipment rack in order to channel away all ESD voltage safely to ground. To guard against ESD damage and shocks, the wrist strap and cord must be in proper working condition.
  - If no wrist strap is available, and you must work with Tdev Development Platforms, ground yourself by touching a metal part of the chassis.
-

## 1.4 Recommended Reading

This document assumes that you have a clear understanding of the installation of the TelcoBridges Tdev Development Platforms and have been trained to work with the equipment. If you have any technical questions, TelcoBridges TB Support (technical support team) can be reached via telephone (+1 866 438 4703) or email: [support@telcobridges.com](mailto:support@telcobridges.com).

Documents exploring various aspects of the Tmedia system are available on the TB Wiki: <http://docs.telcobridges.com>



# Chapter 2     Installing the Equipment

This chapter provides information about the following topics:

- Section 2.1 “Package Contents”
- Section 2.2 “Rack Mounting the Tdev TMP800 Development Platform Equipment”
- Section 2.3 “TMP800-CTRL”
- Section 2.4 “TMP800 Telecom Unit”
- Section 2.6 “Verifying the LED Status Indications”
- Section 2.7 “Powering Down”

## 2.1 Package Contents

Depending on your system requirements, you may receive one or more of the following items:

- Section 2.1.1 “TMP800-CTRL Gateway Controllers” on page 8.
- Section 2.1.2 “TMP800 Telecom Unit” on page 9.

The contents of these devices are described in the following sections.

### 2.1.1 TMP800-CTRL Gateway Controllers

In the TMP800-CTRL box, you will find the following items:

- One (1) TMP800-CTRL. See figure 1.1 on page 2.
- Four (4) keys.
- One (1) front bezel.
- Two (2) hard drives.
- Two (2) power cords.
- One Product Warranty.
- One Important Notice (two-sided document containing pertinent product serial numbers and other important information).
- One (1) packing slip.
- One (1) set of sliding rails and associated screws.
- One (1) set of brackets and associated screws.

Not included

- Ethernet cables.

## 2.1.2 TMP800 Telecom Unit

In the TMP800 Telecom Unit box, you will find the following items:

- One (1) TMP800 unit. See figure 1.1 on page 2.
- One (1) set of mounting brackets and screws, used to mount the TMP800 on a 19" rack.
- One (1) DB-9 to RJ-45 adapter to interface the serial port of your computer with the RJ-45 port of the TMP800.
- Three (3) CAT5 Ethernet (blue) straight cables (male-male), 3 meters in length.
- One (1) Important Notice (two-sided document containing pertinent product serial numbers, and other important information).
- One (1) Product Warranty.
- One (1) packing slip.
- One (1) Quick Installation Guide (two-sided document that provides a pictorial view of the equipment setup).
- Two (2) AC or DC power cables

Not included

- A 19" equipment rack. The Tdev TMP800 Development Platform must be installed on a 19" wide equipment rack.

## 2.2 Rack Mounting the Tdev TMP800 Development Platform Equipment

The Tdev TMP800 Development Platform equipment is mounted on a customer provided equipment rack using the mounting hardware packaged in each box.

### 2.2.1 Prerequisites

To mount the equipment, you will need:

- One customer-provided equipment rack, measuring 19" in width and 31.5" in depth. The rack must be solidly anchored to the floor with appropriate support at the top of the racks.
- Climate controlled room: 0 to +50 Celsius, 0 to 95% non-condensing humidity.

### 2.2.2 Vertical Placement of Tdev TMP800 Development Platform Equipment

The TMP800-CTRL is housed in a 2U chassis while the TMP800 Telecom Unit is each housed in a 1U chassis, as tabulated in table 2.1 on page 10. It is important that you provide for enough room on the equipment rack to allow for the installation of the equipment.

Consider the available space on your equipment rack and the height of one (1) or two (2) TMP800-CTRL unit(s) and one (1) TMP800 Telecom Unit. Due to the rear-exhaust heat vents and the efficient heat dissipation design, there is no need to leave any physical vertical space above or below the TMP800-CTRL unit(s) and the TMP800 Telecom Unit on the equipment rack.

Table 2.1 Tdev Development Platform Physical Height

| Tmedia Model Number | Vertical Height              |
|---------------------|------------------------------|
| TMP800-CTRL         | 2U (3.5 inches or 89.10 mm)  |
| TMP800 Telecom Unit | 1U (1.75 inches or 44.45 mm) |



## 2.2.3 Installing the Tdev TMP800 Development Platform on an Equipment Rack

The TMP800-CTRL, and TMP800 Telecom Unit are mounted on a 19" equipment rack using the angle brackets and screws provided in the box.

### 2.2.3.1 TMP800-CTRL

#### **Mounting the TMP800-CTRL Unit(s):**

The TMP800-CTRL is installed in a 19" equipment rack using one of the following two methods:

#### **Method One: Slider Rails**

1. Install the left sliding rail on the left-hand side of the equipment rack.
  - 1a. Attach the front end of the slider rail to the front edge of the equipment rack. See figure 2.1 on page 12.
  - 1b. Attach the rear end of the slider rail to the rear edge of the equipment rack. See figure 2.2 on page 12 and figure 2.3 on page 13.
2. Repeat Step 1 to install the right sliding rail on the right-hand side of the equipment rack.
3. Extend both sliding rails. See figure 2.4 on page 13.
4. Attach the TMP800-CTRL to the rails. See figure 2.5 on page 14 and figure 2.6 on page 14.
5. Push the TMP800-CTRL back into the equipment rack until it locks into place.

---

**Note** To unlock the rails and slide the TMP800-CTRL outwards from the equipment rack, depress the purple colored buttons on each side of the sliding rails.

---

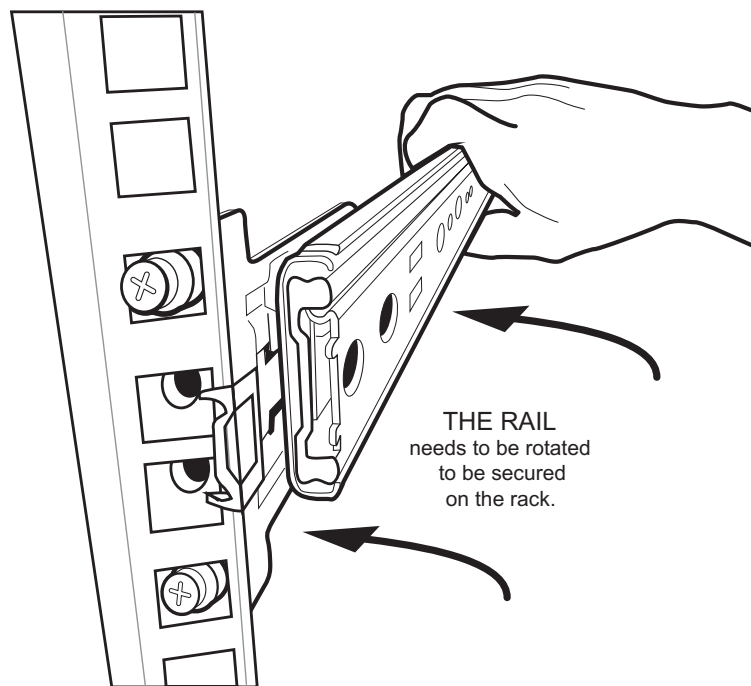

Figure 2.1 Securing the Slider Rail to the Front of the Equipment Rack

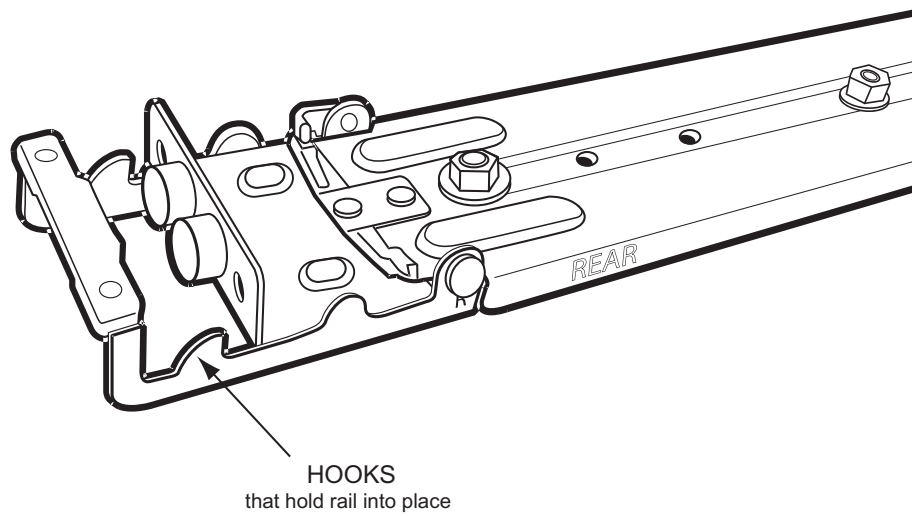

Figure 2.2 Detail View of Slider Rail Rear Retaining Hooks

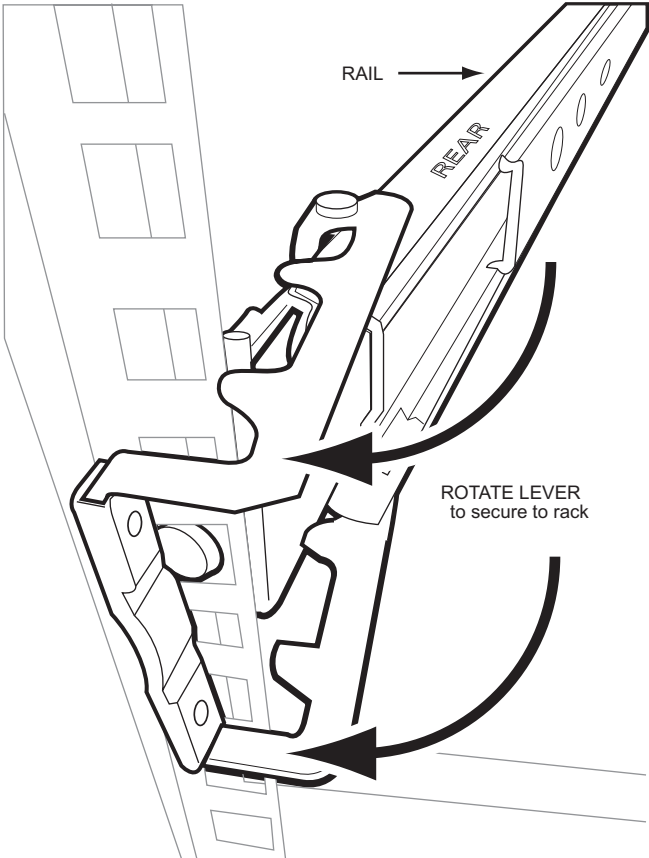

Figure 2.3 Detailed View of Slider Rail Rear Retaining Hooks being Locked onto the Rear of the Equipment Rack

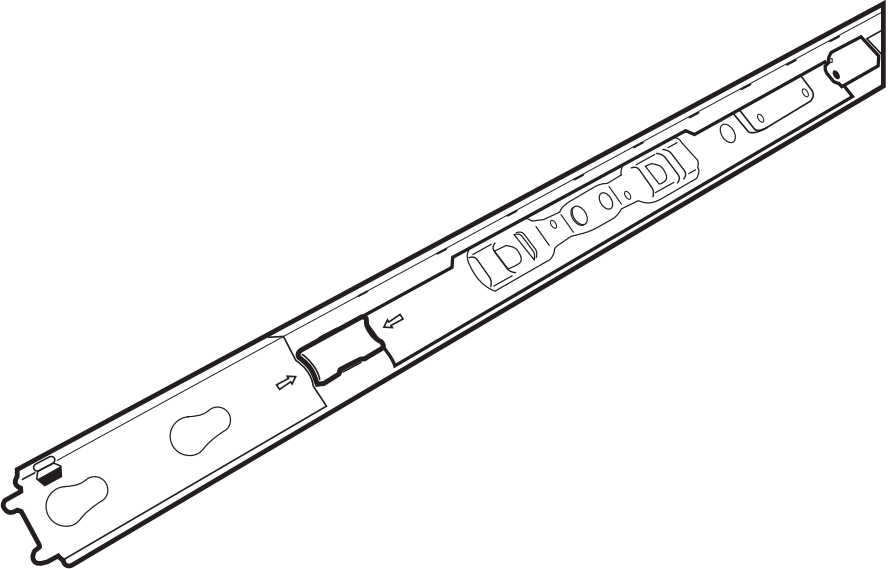

Figure 2.4 Detailed View of the Slider Rail Release Mechanism

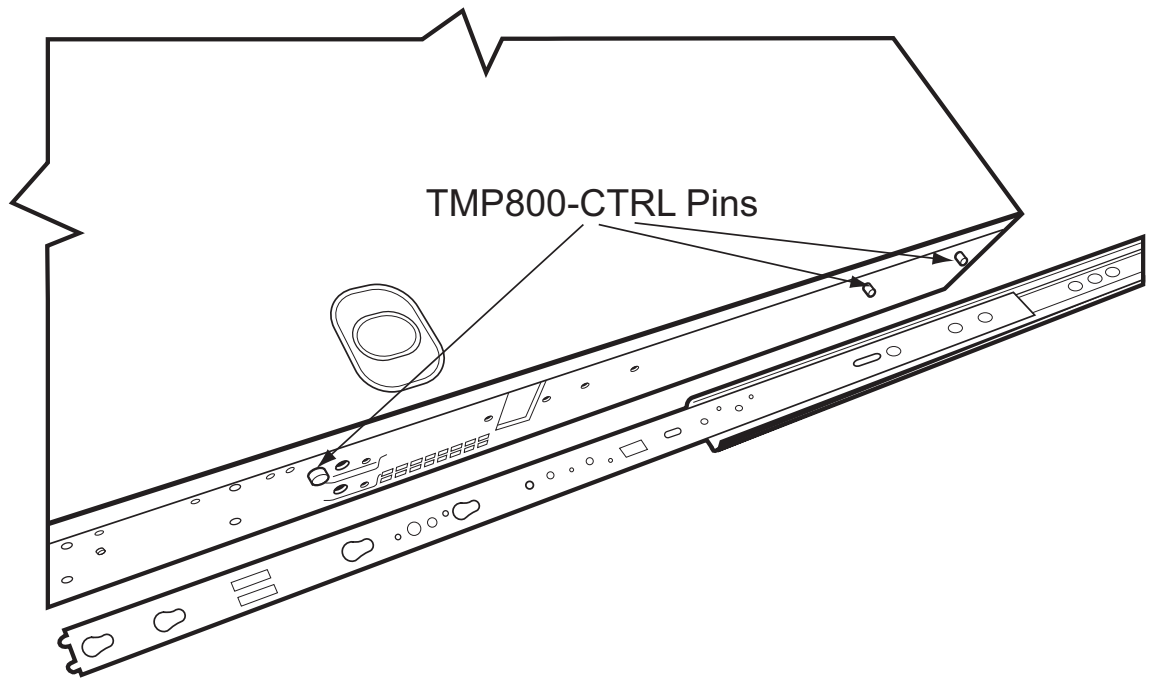

Figure 2.5 Attaching Sliding Rails to the TMP800-CTRL Mounting Pins

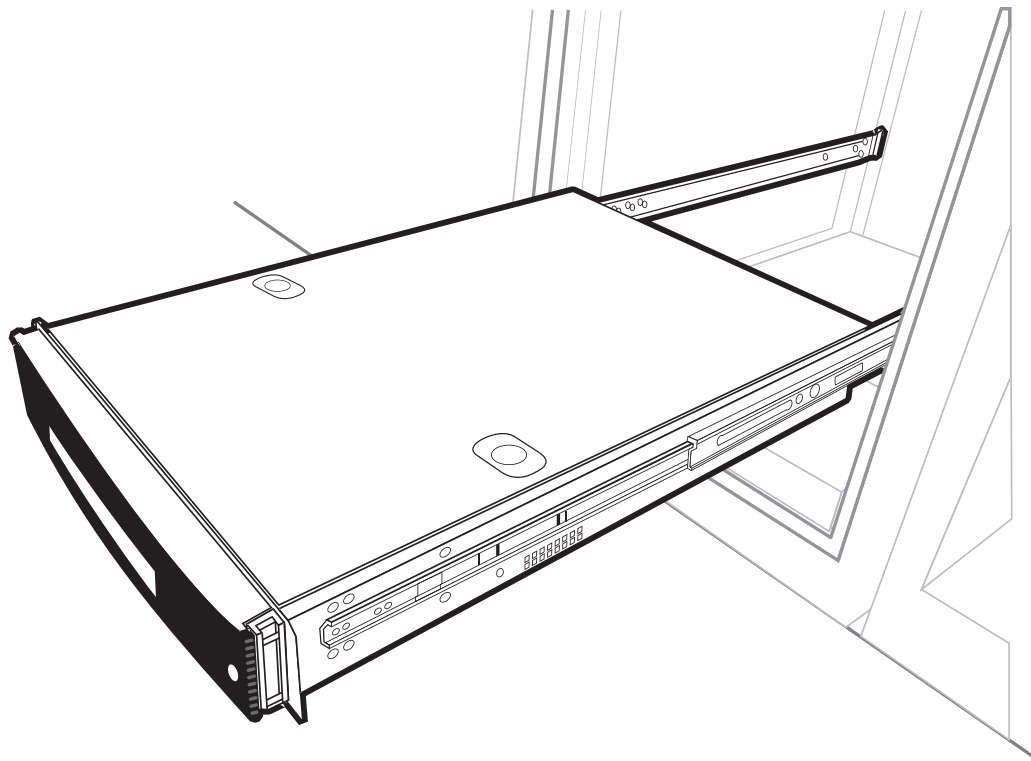

Figure 2.6 TMP800-CTRL Installed on Slider Rails in the Fully Extended Position

**Method Two: Fixed Brackets**

1. Install the fixed brackets on the TMP800-CTRL, adjusting their position in accordance with the equipment rack depth. See figure 2.7 on page 15.
2. Mount the TMP800-CTRL on the equipment rack.
3. Secure it in place using the screws provided with the bracket. See figure 2.8 on page 15 and figure 2.9 on page 16.

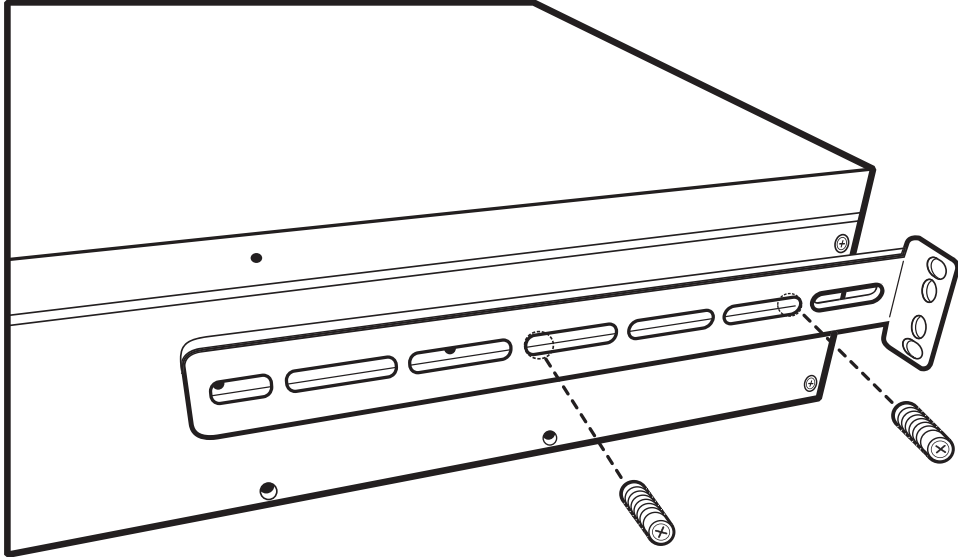

Figure 2.7 Attaching the Rear Brackets to the TMP800-CTRL

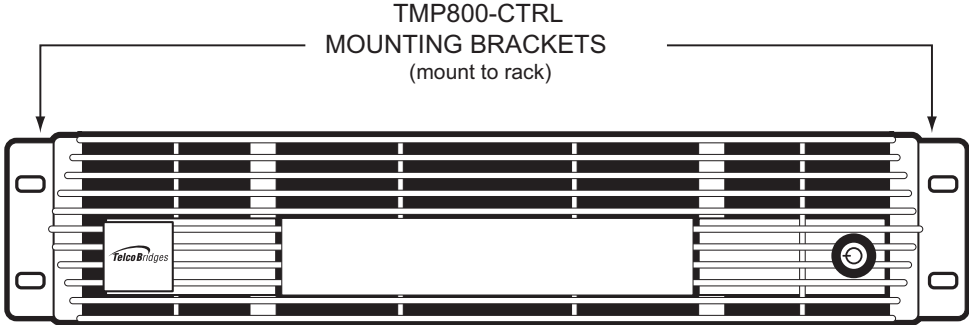

Figure 2.8 Front View of TMP800-CTRL with Front Mounting Brackets

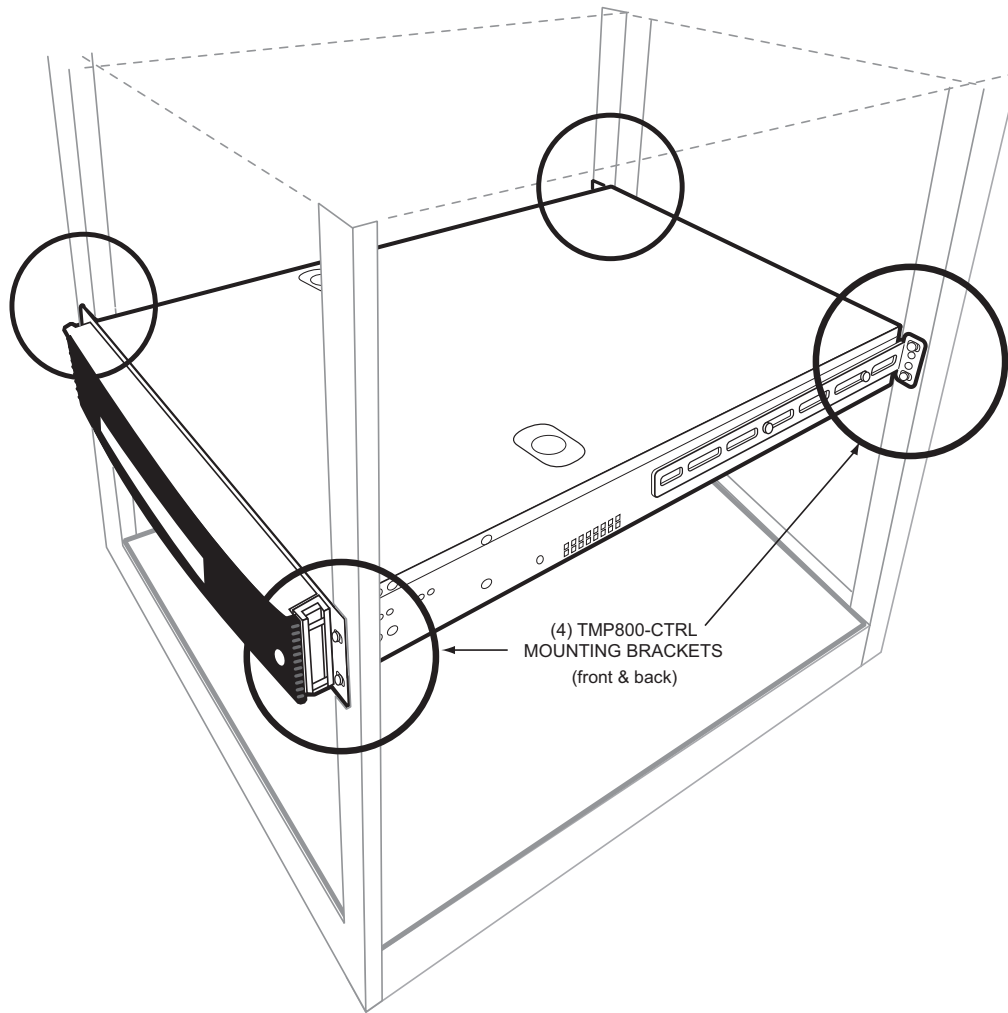

Figure 2.9 TMP800-CTRL Installed in the Equipment Rack

## Installing the Hard Drives

To install the hard drives, do the following:

1. Using the bezel key, unlock and remove the TMP800-CTRL front bezel. See figure 2.10 on page 17, figure 2.12 on page 18, and figure 2.13 on page 18.
2. Using the hard disk key, open the top hard disk tray. See figure 2.14 on page 19, and figure 2.15 on page 19.
3. Insert the top disk drive. See figure 2.11 on page 17 and figure 2.16 on page 20.
4. Close the top hard disk tray. See figure 2.17 on page 20.
5. Repeats steps 2-4 to install the bottom disk drive.
6. Reinstall the front bezel.

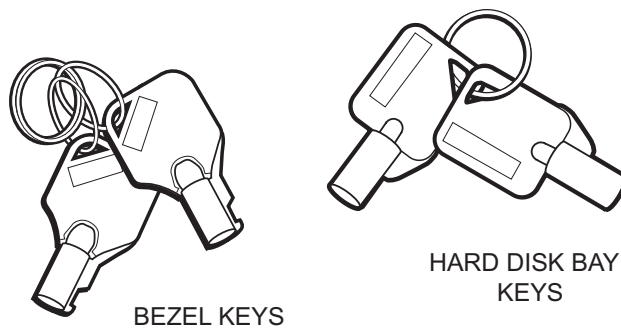

Figure 2.10 Bezel and Hard Disk Keys

Figure 2.11 Top View of Hard Disks 1 and 2.

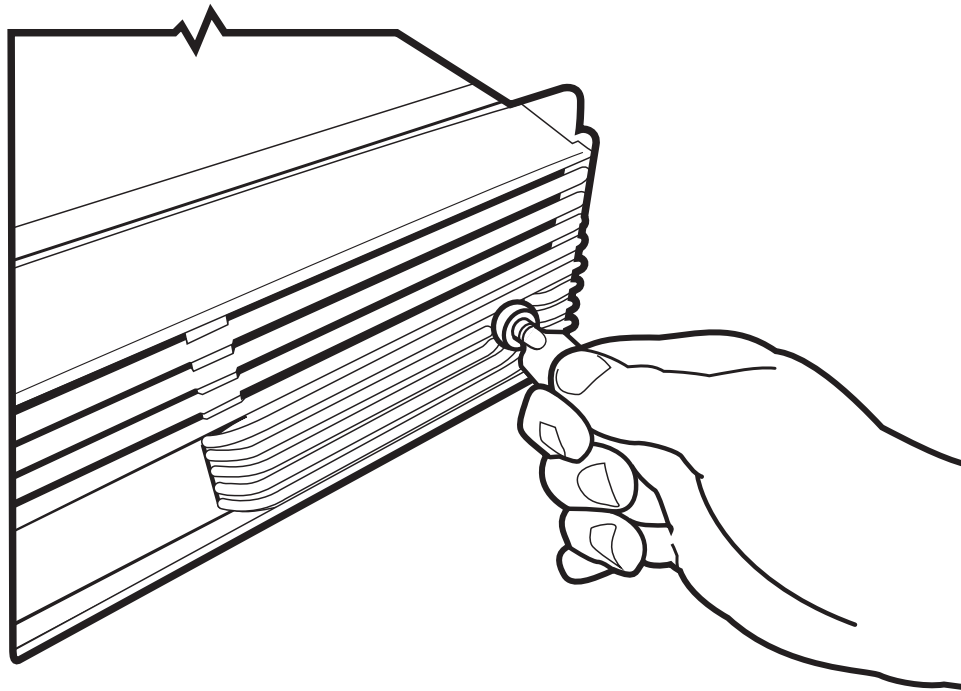

Figure 2.12 Unlocking the Front Bezel of the TMP800-CTRL

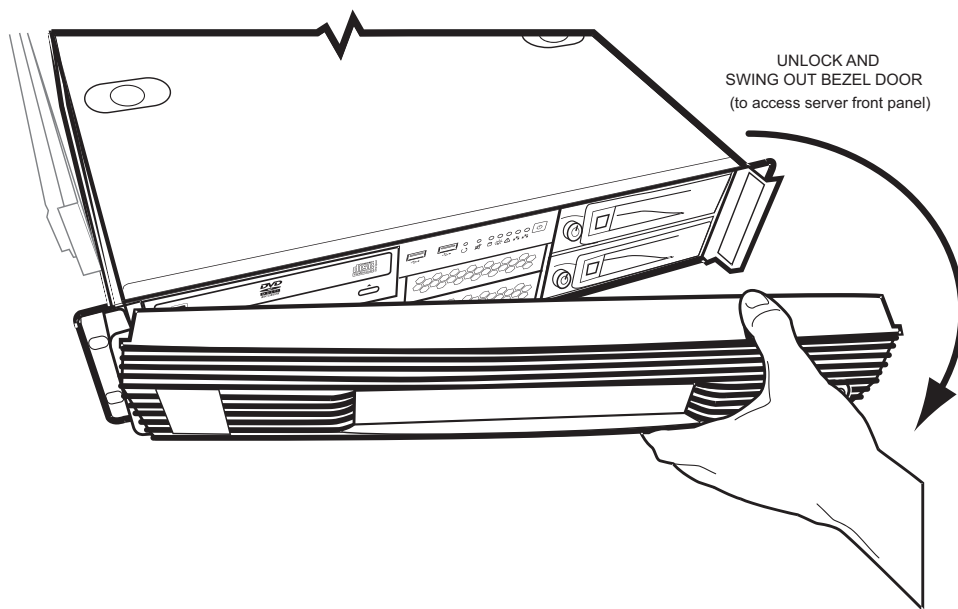

Figure 2.13 Opening the Front Bezel to Access the Hard Disks of the TMP800-CTRL



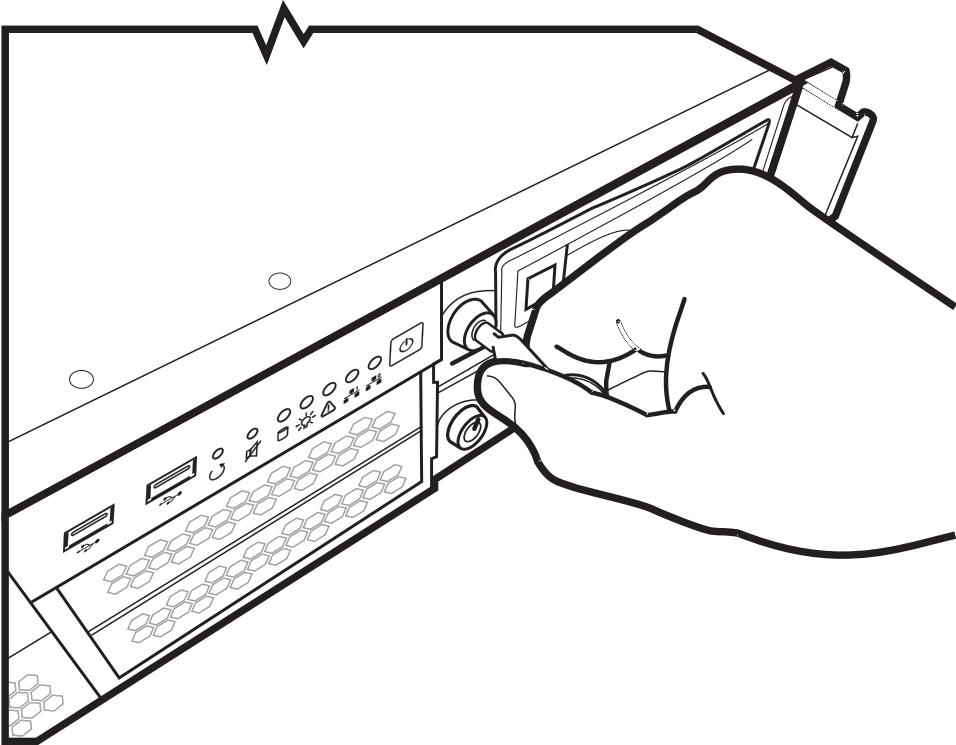

Figure 2.14 Unlocking the Hard Disk Door

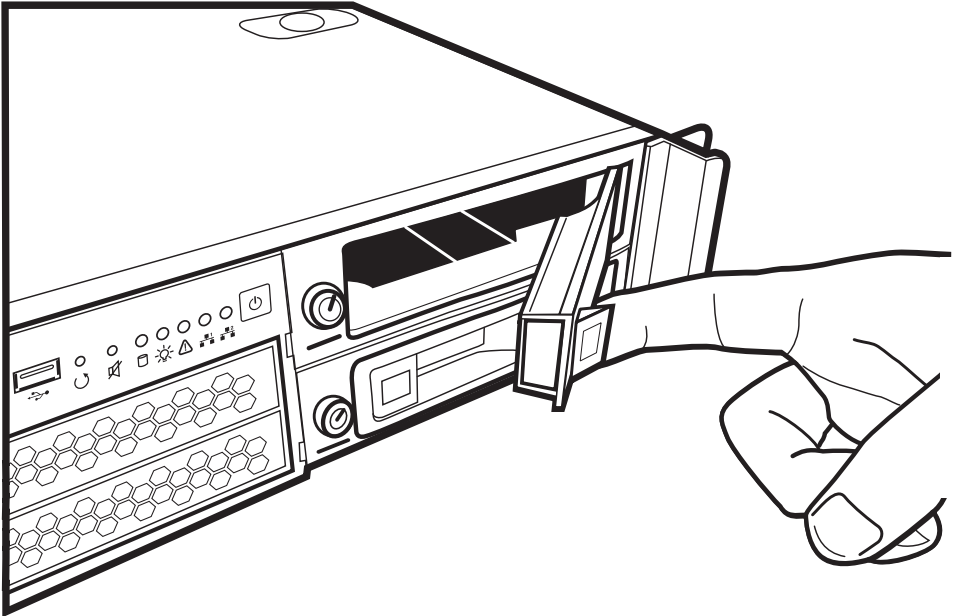

Figure 2.15 Opening the Hard Disk

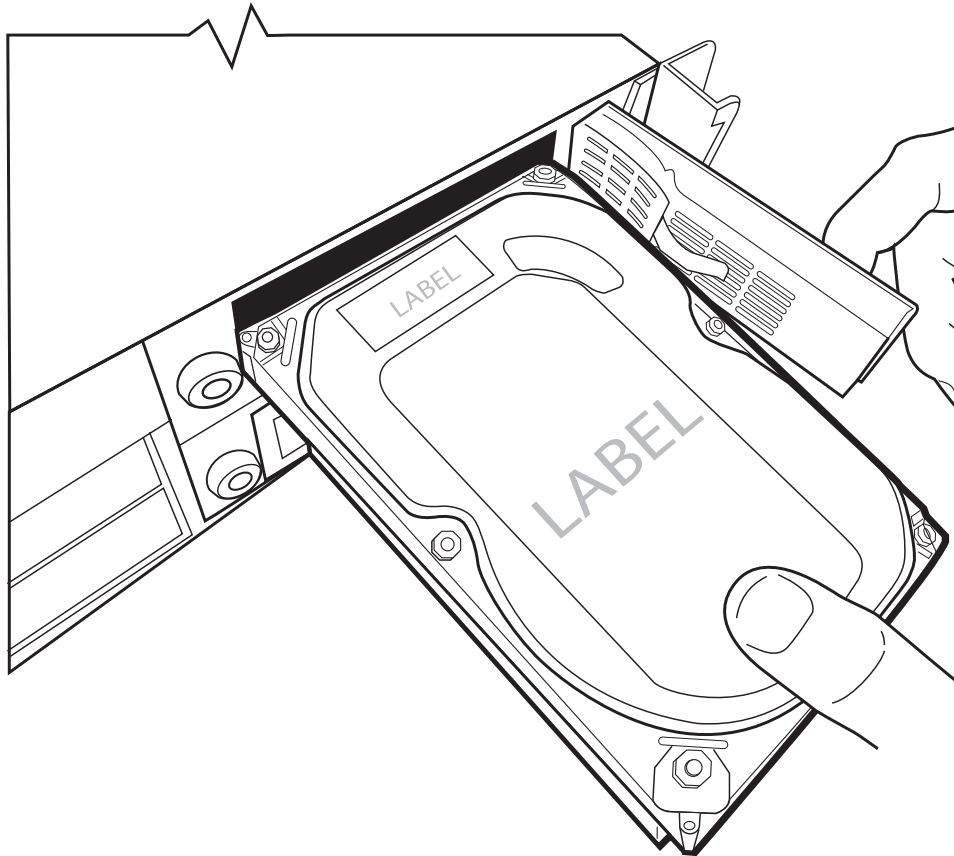

Figure 2.16 Inserting the Hard Disk

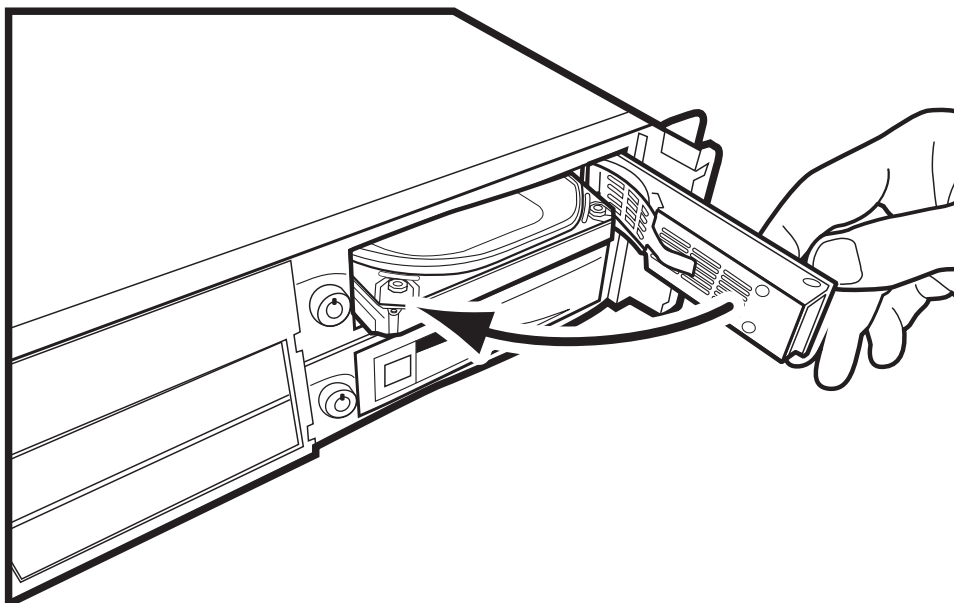

Figure 2.17 Closing the Hard Disk Door

### 2.2.3.2 TMP800 Telecom Units

#### **Mounting the TMP800 Telecom Unit(s):**

1. Using four metal screws, attach one angle bracket to the front, left-hand side of the TMP800 Telecom Unit, when viewed from the front. Do the same for the angle bracket on the right-hand side.
2. Start mounting equipment beneath the TMP800-CTRL, keeping in mind the space required on the equipment rack as described in Section 2.2.2 “Vertical Placement of Tdev TMP800 Development Platform Equipment” on page 10.

## 2.3 TMP800-CTRL

This section covers the following procedures:

- Section 2.3.1 “Connecting to the System Management Interface” on page 22.
- Section 2.3.2 “Connecting to the Tmedia Control Network” on page 23.
- Section 2.3.3 “Powering Up” on page 24.
- Section 2.5 “Start Up” on page 33.

## 2.3.1 Connecting to the System Management Interface

The Tmedia Management Interface enables administrators to perform management tasks on a TMP800-CTRL.

### Prerequisites

To communicate with the Tmedia Management Interface, the following is needed:

- One CAT5 Ethernet cable with RJ45 male-male terminations.

---

**Note** Ethernet cables are not supplied with the TMP800-CTRL.

---

### To communicate with the Tmedia Management Interface:

1. Connect an RJ45 cable from the TMP800-CTRL to a Gigabit Ethernet switch.

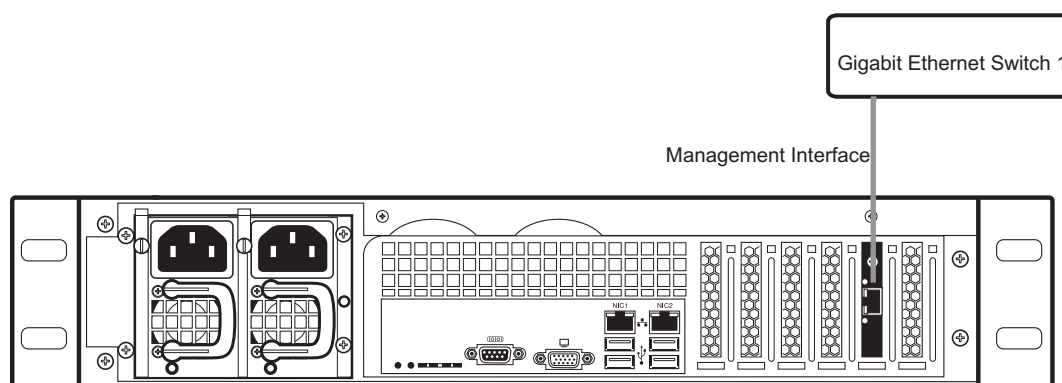

Figure 2.18 TMP800-CTRL System Management Interface

## 2.3.2 Connecting to the Tmedia Control Network

The Tmedia Control network enables communication between the TMP800-CTRL and the TMP800 Telecom Unit.

### Prerequisites

To connect the TMP800 to the Tmedia control network, you will need:

- One CAT5 Ethernet cable with RJ45 male-male terminations.

### Connections

The TMP800-CTRL is connected to the Tmedia control network using one CAT5 Ethernet cable, as shown in figure 2.19 on page 23.

#### To connect to the Tmedia control network:

1. Connect the NIC1 connector on the TMP800-CTRL to the Tmedia Control network switch one.

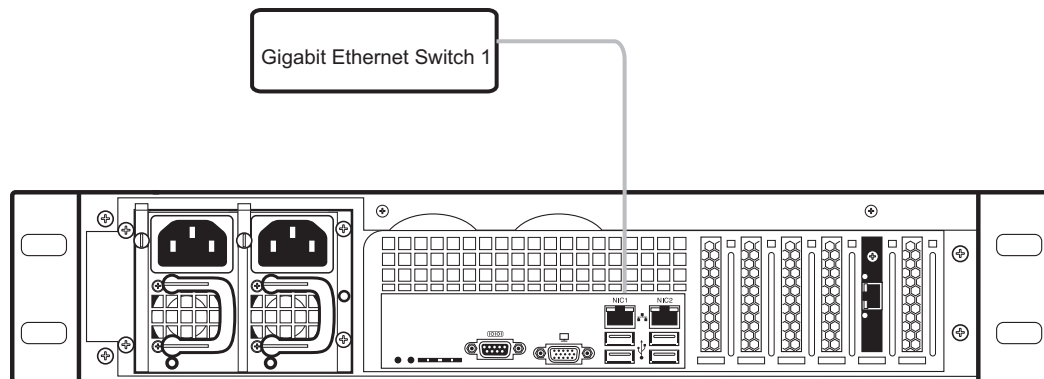

Figure 2.19 Connecting to the Tmedia Control Network

## 2.3.3 Powering Up

The TMP800-CTRL is furnished with two (2) AC or two (2) DC power connections. Only once all other equipment installation work has been completed should the Tdev Development Platform be powered up.

### Prerequisites

To power the TMP800-CTRL, you will need:

- Two independent AC or DC power sources.
- Two power cables.

### 2.3.3.1 Connecting to AC Power

The TMP800-CTRL is furnished with two AC power connectors.

#### To connect the TMP800-CTRL to AC Power:

1. Connect the first power connector of the TMP800-CTRL to the first power source. See Figure 2.20.
2. Connect the second power connector of the TMP800-CTRL to the second power source.

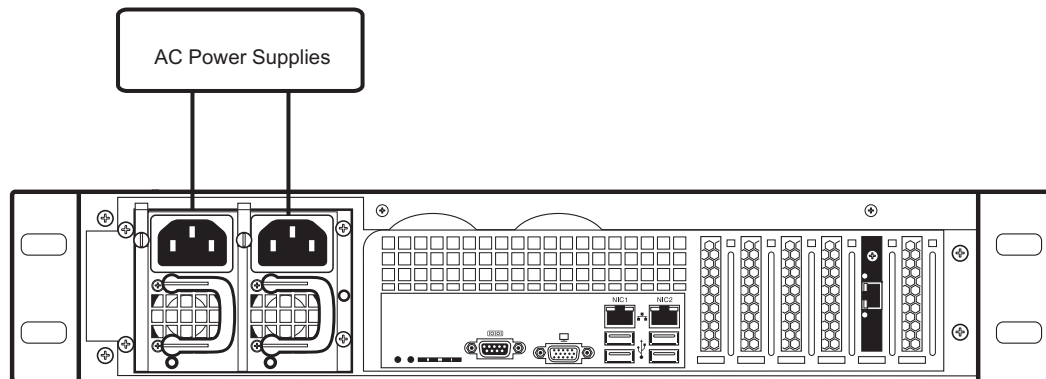

Figure 2.20 TMP800-CTRL AC Power Connections

### 2.3.3.2 Connecting to DC Power

The TMP800-CTRL is furnished with two DC power connection ports. In addition, each DC powered TMP800-CTRL is supplied with two DC power cables.

#### To connect the TMP800-CTRL to DC Power

1. Connect the first DC power connector of the TMP800-CTRL to DC power source one. See figure 2.21 on page 25.
  - 1a. Connect one lead of each DC power cable to the positive terminal of the DC power source.
  - 1b. Connect the other lead of each DC power cable to the negative side of the DC power source.
2. Repeat the previous steps for DC power source two.

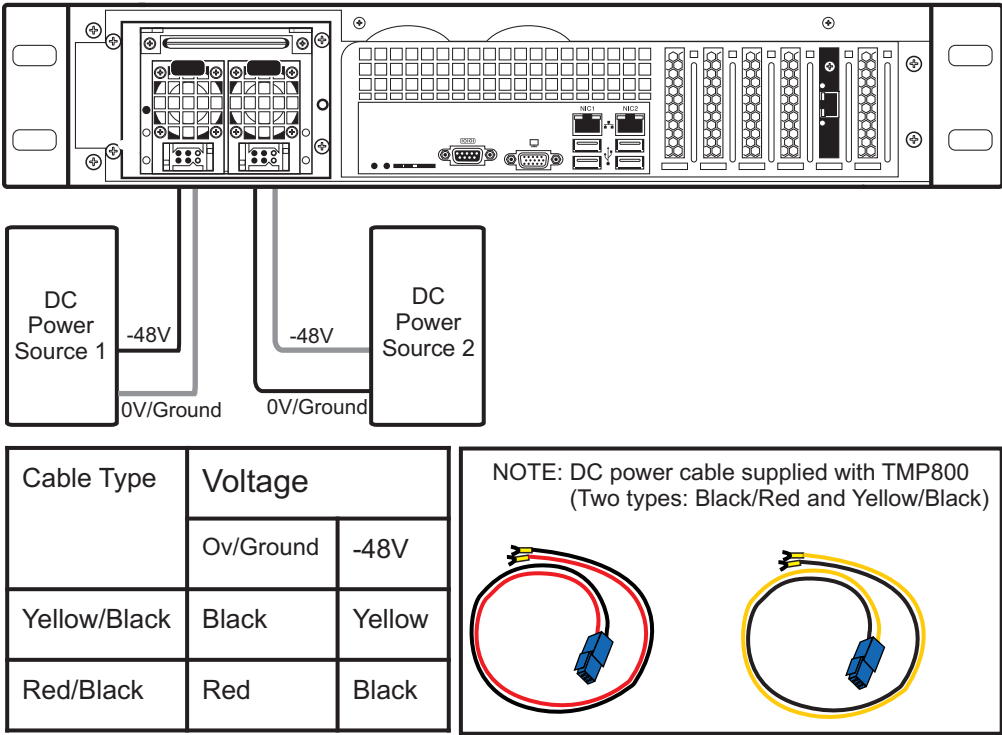

Figure 2.21 TMP800-CTRL DC Power Connections

## 2.4 TMP800 Telecom Unit

This section covers the following procedures:

- Section 2.4.1 “Connecting to the Tmedia Control Network” on page 27.
- Section 2.4.2 “Connecting to a VoIP Network” on page 28.
- Section 2.4.3 “Connecting to the PSTN” on page 29.
- Section 2.4.4 “Powering Up” on page 30.



## 2.4.1 Connecting to the Tmedia Control Network

The Tmedia Control Network enables administrators to perform management tasks on the TMP800.

### Prerequisites

To communicate with the Tmedia Control Network, the following is needed:

- One CAT5 Ethernet cable with RJ45 male-male terminations.

### Interconnections

The TMP800 provides a Tmedia Control Network Interface, using one Gigabit Ethernet network link, as shown in figure 2.22 on page 27.

#### To communicate with the Tmedia Control Network:

1. Connect the supplied CAT5 Ethernet cable to the port labelled “ETH0” at the rear of the TMP800.

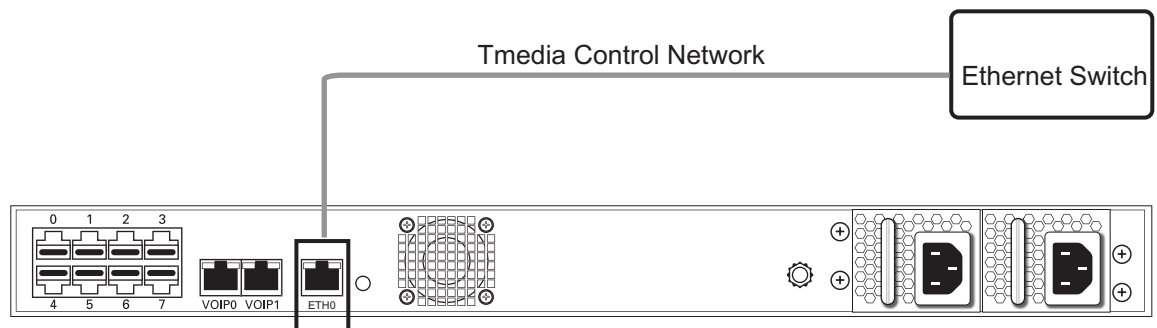

Figure 2.22 Tmedia Control Network

## 2.4.2 Connecting to a VoIP Network

The TMP800 features dual GigE ports for connection to different VoIP networks. This provides an access point to manage VoIP traffic. Should one of the IP networks fail, the TMP800 will continue to manage VoIP traffic using the alternate network.

The IP address of the VoIP ports can be modified using the web portal.

---

**Note:** Certain configurations of the TMP800 will exceed 100 Mbps, therefore 1000 Mbps is recommended.

---

### Prerequisites

To connect the TMP800 to the VoIP network, you will need:

- Gigabit layer 2 Ethernet switch. A second one is required to support redundancy of the VoIP interface.
- One or two CAT5 Ethernet cables with RJ45 male-male terminations.
- If your system has access to a second VoIP network, you can connect it to a second VoIP interface of the TMP800 with an RJ45 (male-male) CAT5 Ethernet cable.

### Connections

The TMP800 is connected to the VoIP network by one or optionally two Ethernet GigE network links, as shown in figure 2.23 on page 28.

#### To connect the TMP800 to the VoIP network:

1. Connect a CAT5 Ethernet cable to VoIP0 at the rear of the TMP800. Connect the other end of the same CAT5 cable to the Gigabit Ethernet switch.
2. If your system employs a second Gigabit Ethernet switch for redundancy, connect a second CAT5 Ethernet cable to VoIP1 at the rear of the TMP800. Connect the other end of the same CAT5 cable to the second Gigabit Ethernet switch.

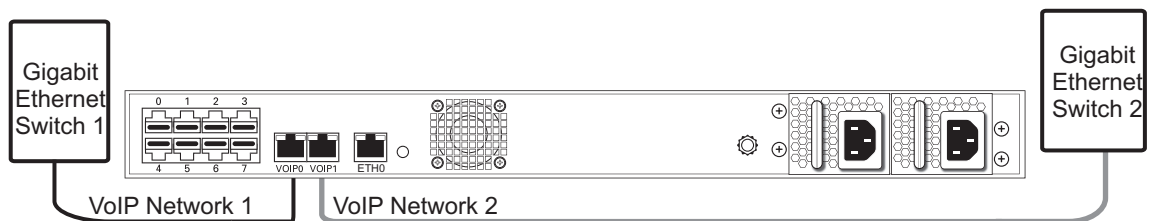

Figure 2.23 Connecting to the VoIP Network

## 2.4.3 Connecting to the PSTN

A TMP800 with 8 RJ48C type ports enables the connection to T1/E1 lines. The termination impedance is set at 100 ohms for T1 lines and 120 ohms for E1 lines. It is possible to connect an external balun in order to convert the line impedance to 75 ohms.

If you are making your own cables, refer to page 50 in Appendix A for crossover or straight cable wiring connections.

---

**Note** All ports may not be active. T1/E1 ports are activated by software license; the number of active ports depends on the licenses purchased.

---

### To connect the TMP800 (RJ48C type) to the PSTN:

1. Start with port 0 located at the top and leftmost position. Connect one cable between this port and the T1/E1 line. See figure 2.24 on page 29.
2. Repeat step 1, using the next available port.



Figure 2.24 8-Port Interface to the PSTN

## 2.4.4 Powering Up

The TMP800 is furnished with one (1) or two (2) AC or DC power connections. Only once all other equipment installation work has been completed should the TMP800 be powered up.

### 2.4.4.1 Connecting to AC Power

#### Prerequisites

To power the TMP800, you will need:

- One to two power sources.
- Two power cables for the TMP800.

#### To connect the TMP800 to AC Power:

1. Connect an AC power cable to each AC connector of the TMP800 and an AC supply. See figure 2.25 on page 30.

---

**Note** If the TMP800 features redundant power supplies, it is important to connect both power supplies in order to avoid setting off its audible alarm.

---

2. Power up the TMP800 by turning on its power switch(es).

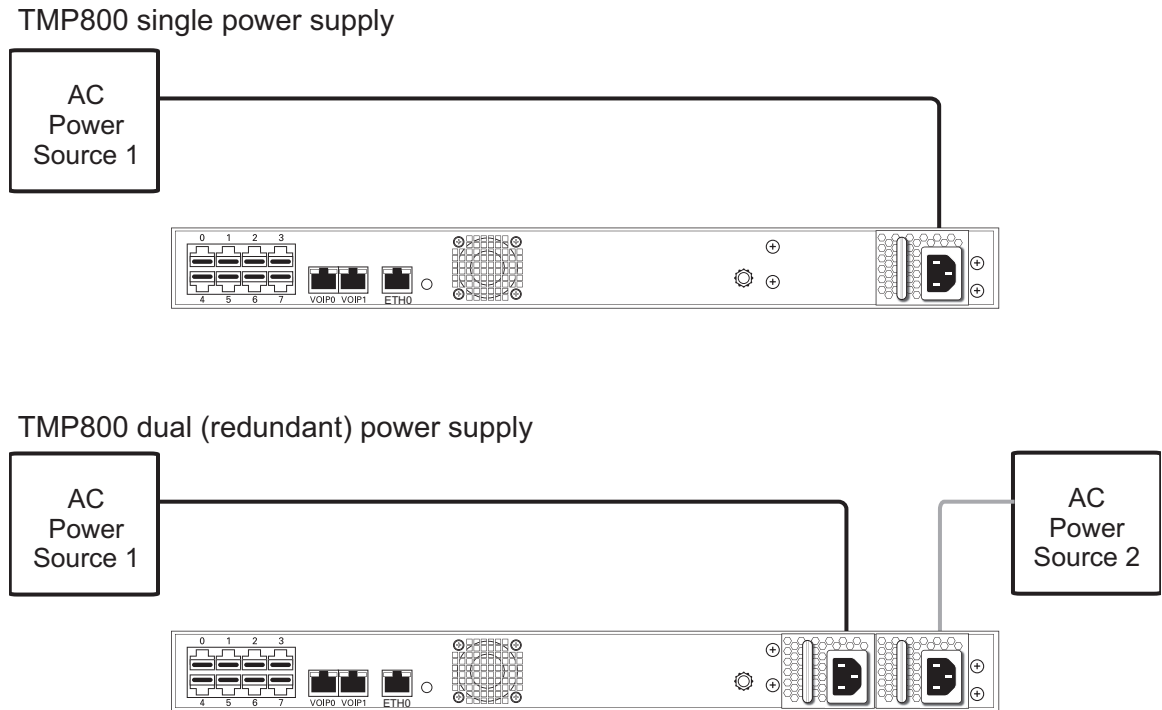

Figure 2.25 AC Power Connection

### 2.4.4.2 Connecting to DC Power

The TMP800 DC model is furnished with one or two power connection ports. In addition, each DC powered TMP800 is supplied with either one or two DC power cables.

**To connect the TMP800 to DC power:**

**Note** Two types of cable with different coloring are available. Refer to figure 2.26 on page 31 for the appropriate wiring information.

The connection of DC power is described for:

- Single DC power connection port
- Dual DC power connection port

**To connect a TMP800 with a single DC power supply:**

1. Connect a ground wire to the ground plug located at the rear of the TMP800, as shown in figure 2.26 on page 31.
2. Connect a 14 AWG wire between the positive terminal of a DC power source and the terminal on the TMP800 labelled as .
3. Connect a 14 AWG wire between the negative terminal of a DC power source and the terminal on the TMP800 labelled as 48V.

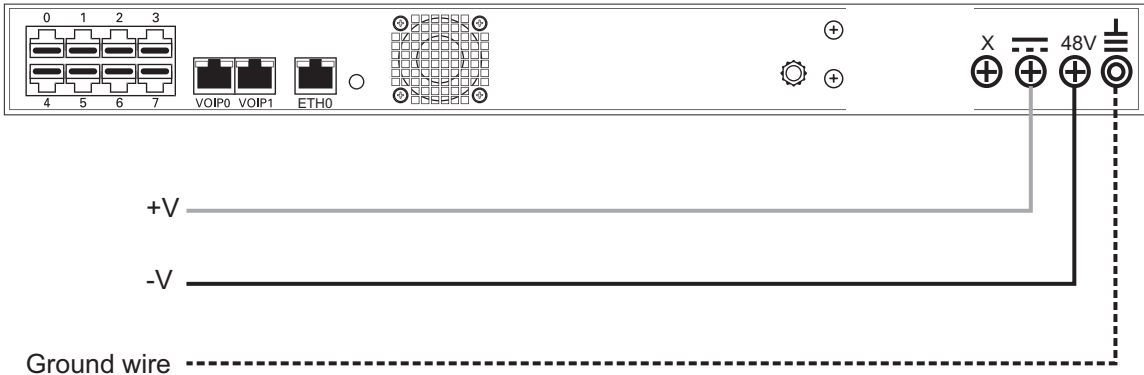

Figure 2.26 TMP800 DC Wiring Diagram

**To connect a TMP800 with dual DC (redundant) DC power:**

1. Connect one DC cable supplied with the TMP800, as shown in figure 2.27 on page 32, to the DC outlet at the rear of the TMP800.

**Note** Two types of cable with different coloring are available. Refer to figure 2.27 on page 32 for the appropriate wiring information.

2. Connect one lead of the DC power cable to the positive terminal of the DC power source, as shown in figure 2.27 on page 32.
3. Connect the other lead of the DC power cable to the negative side of the DC power source.
4. Repeat steps 1-3 for the second power DC power source.

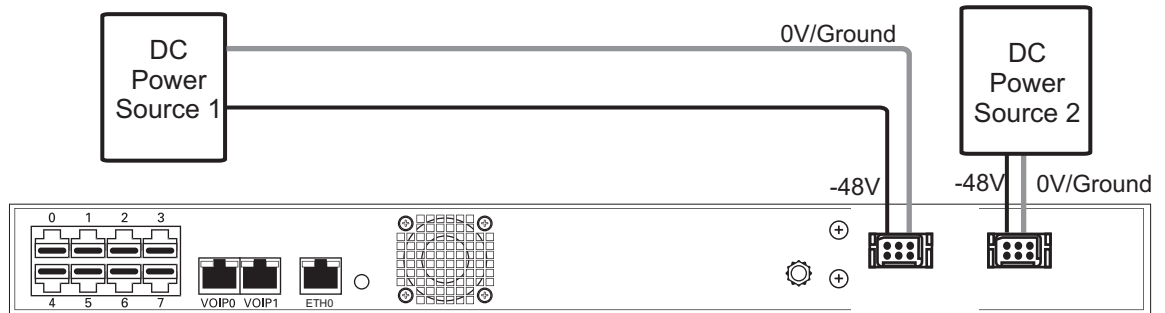

| Cable Type   | Voltage   |        |
|--------------|-----------|--------|
|              | 0v/Ground | -48V   |
| Yellow/Black | Black     | Yellow |
| Red/Black    | Red       | Black  |

NOTE: DC power cable supplied with TMP800 (Two types: Black/Red and Yellow/Black)

Figure 2.27 TMP800 Redundant DC Supply Wiring Diagram

## 2.5 Start Up

After powering up the TMP800-CTRL, you must select one of the servers to be the primary server. If you have a second server, configure it as a secondary.

Once these configuration settings have been applied, your Tdev TMP800 Development Platform will start up and display the web portal configuration management tool.

### 2.5.1 Primary

1. Connect to the web portal. The Welcome page appears.

#### Welcome to the TelcoBridges Tmedia Web Portal!

Please take the time to complete the following steps to ensure the proper, initial configuration of your TMG7800-ctrl server unit. For access to our Tmedia Installation Guides, visit [TMedia Installation guides](#).

You are configuring the following TMG7800-ctrl server unit:

Model: **TMedia TMG7800-ctrl**  
 Serial number: **srv-test-centos53-x64-1**  
 Allowed modes: **primary or secondary**

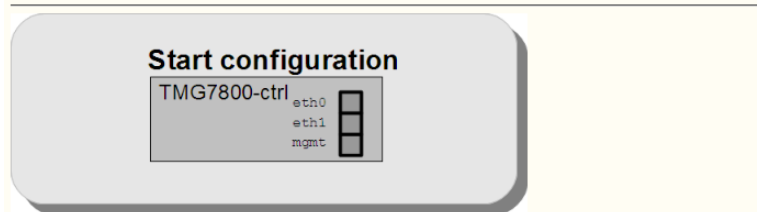

**Note:** The Welcome page indicates whether the TMP800-CTRL is a primary or secondary unit.

2. Select the top portion of the image to configure the TMP800-CTRL as a primary unit.

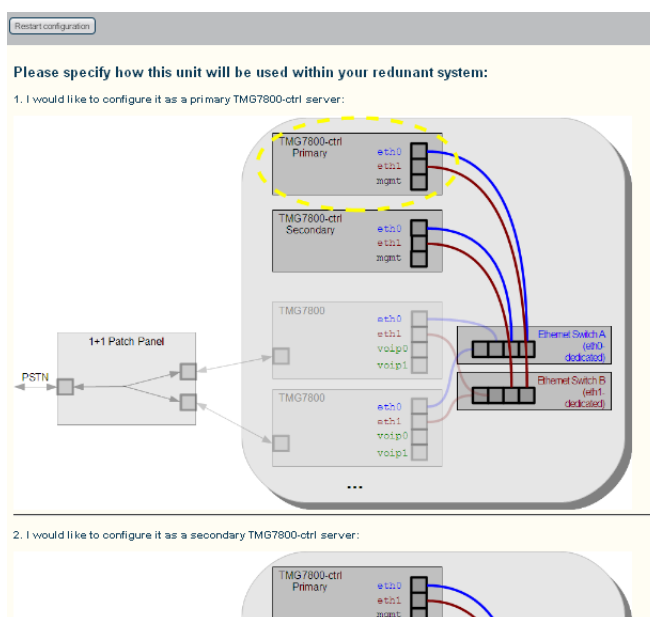

3. Select New Redundant.

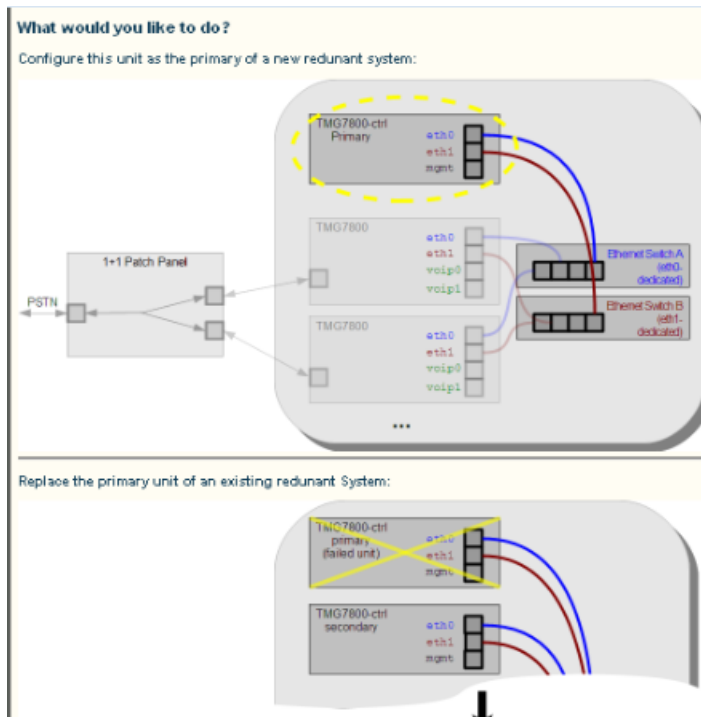

4. Before clicking the **Yes, it's connected like that already**, verify that the physical connections have been properly done.

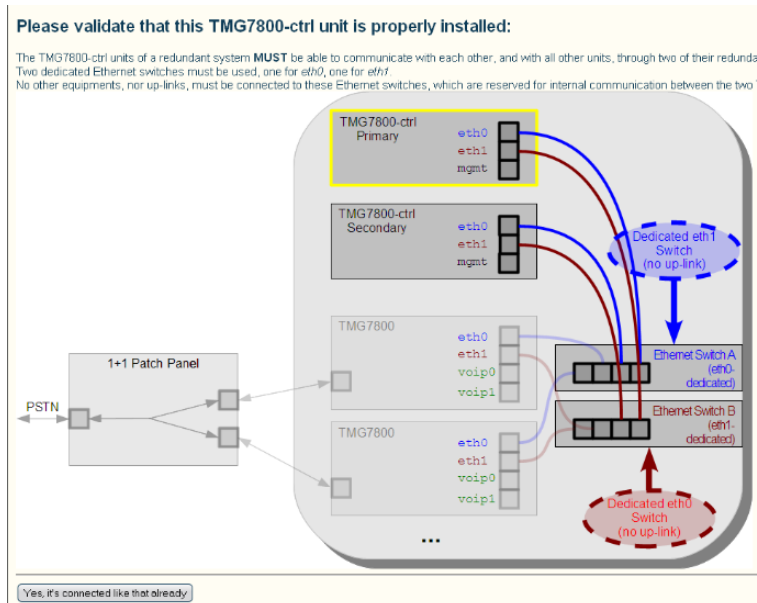



## 2.5.2 Secondary

1. Connect to the web portal. The Welcome page appears.

### Welcome to the TelcoBridges Tmedia Web Portal!

Please take the time to complete the following steps to ensure the proper, initial configuration of your TMG7800-ctrl server unit. For access to our Tmedia Installation Guides, visit [Tmedia Installation guides](#).

You are configuring the following TMG7800-ctrl server unit:

Model: **TMedia TMG7800-ctrl**

Serial number: **svr.test.centos53-x64-1**

Allowed modes: **primary or secondary**

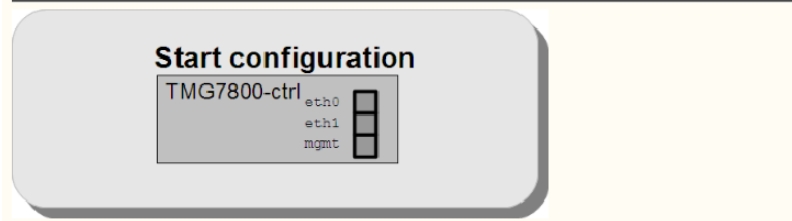

---

**Note:** The Welcome page indicates whether the TMP800-CTRL is a primary or secondary unit.

---

- Select the bottom portion of the image to configure the TMP800-CTRL as a secondary unit.

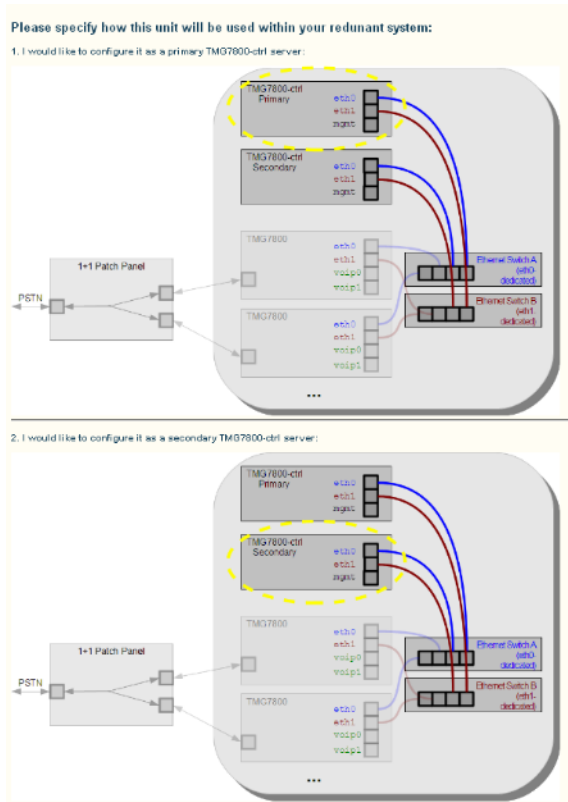

- Before clicking the **Yes, it's connected like that already**, verify that the physical connections have been properly done.

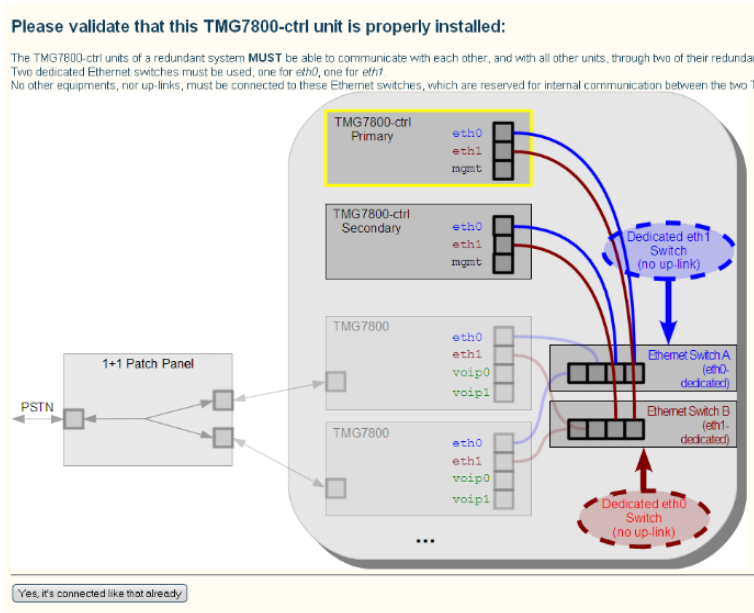

## 2.6 Verifying the LED Status Indications

When the Tdev Development Platform has been powered up, verify the front panel of each unit to determine that all indications are normal.

### 2.6.1 TMP800-CTRL

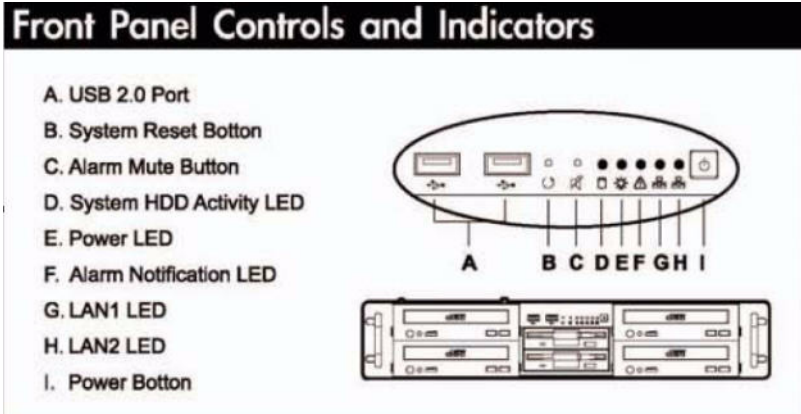

Table 2.2 TMP800-CTRL Indicators





| Display Order                    | Display   |
|----------------------------------|---|
| System HDD Activity LED (yellow) | Indicates the operation of the hard drive: <ul style="list-style-type: none"> <li>• Blinking = active</li> <li>• No light = inactive</li> </ul> |
| Power LED (blue)                 | <ul style="list-style-type: none"> <li>• On = powered</li> <li>• Off = unpowered</li> </ul>   |
| Alarm Notification LED (red)     | <ul style="list-style-type: none"> <li>• On = stem error</li> <li>• Off = no alarm</li> </ul>   |
| LAN 1 LED (green)                | <ul style="list-style-type: none"> <li>• On = LAN is busy</li> <li>• Off = no connection</li> </ul>   |
| LAN 2 LED (green)                | <ul style="list-style-type: none"> <li>• On = LAN is busy</li> <li>• Off = no connection</li> </ul>   |

## 2.6.2 TMP800 Telecom Unit

### Front of Unit

When the TMP800 Telecom Unit has been powered, verify the front panel to determine that all indications are normal. See Table 2.3 on page 38.

Table 2.3 Tmedia Unit Displays

| LED   | Description  |
|---|--|
|    | <ul style="list-style-type: none"> <li>Unused</li> </ul>   |
|    | <ul style="list-style-type: none"> <li>Off: Not Ready</li> <li>Flashing Red: Unit has failed during the boot up process.</li> <li>Flashing Orange: The unit will shut down in a few minutes.</li> <li>Flashing Green: The unit is performing a boot up.</li> <li>Steady Green: The unit has successfully performed a boot up.</li> </ul> |
|    | <ul style="list-style-type: none"> <li>Off: Unpowered</li> <li>Steady Red: Initial Startup sequence</li> <li>Steady Green: Powered</li> </ul>  |
|  | <ul style="list-style-type: none"> <li>Off: No hard drive activity</li> <li>Steady Green: Read/Write activity on the hard drive.</li> </ul>  |

**Note**

An alarm will sound if one of the power supplies is faulty. There is no alarm button to disable the alarm. To stop the alarm, you must remove the faulty power supply.

Pressing the Reset button for 1 second will force the unit into a graceful shutdown. This will take a few minutes. Pressing the reset button for 10 seconds will force the Tmedia VoIP Gateway into an abrupt shutdown. This method should only be used in extreme cases.



Figure 2.28 Front display and LEDs

---

## 2.7 Powering Down

### 2.7.1 TMP800-CTRL

Powering down the Tdev Development Platform requires that the Linux embedded host be shut down. In order to do this, you must connect to the management interface using SSH, and enter:

```
shutdown -hP now
```

---

**Attention** DO NOT TURN OFF the power to the Tdev Development Platform system using the power switch located at the rear, unless the Linux host has been properly shut down beforehand, instead use the reset button display, or manually use the shutdown command.

Allow enough time for the Linux host to shut down before turning off the power to the Tdev Development Platform (ex. 1 minute). Be aware that the shutdown procedure of the unit is logged and traceable for support and warranty purposes.

---

---

**Note** As an alternate method to this procedure, refer to Section 2.6 “Verifying the LED Status Indications” on page 37, to power down the Tdev Development Platform with the reset button.

---

### 2.7.2 TMP800 Telecom Unit

Unplug the power cord from the unit. The unit can be restarted using restart button on the front of the unit.



# Chapter 3 Initial System Configuration

This chapter provides information about the following topics:

- Section 3.1.1 “Connecting to the Serial Port of the TMP800-CTRL”
- Section 3.2 “Configuring the Terminal Emulator Application”
- Section 3.3 “Connecting to the Tdev Development Platform”
- Section 3.4 “Retrieving Tdev Development Platform Information”
- Section 3.5 “Changing the Tdev Development Platform Management Port IP Address”
- Section 3.5 “Changing the Tdev Development Platform Management Port IP Address”
- Section 3.7 “Setting the Time Zone”
- Section 3.8 “Configuring the Tdev Development Platform Using the Web Portal”
- Section 3.9 “Changing VoIP Interface Addresses”

## 3.1 Connecting to the Serial Port of the Tdev Development Platform

The connection to the serial port of the Tdev Development Platform is comprised of the following procedures:

- Connecting to the Serial Port of the TMP800-CTRL
- Connecting to the Serial Port of the TMP800 Telecom Unit

### 3.1.1 Connecting to the Serial Port of the TMP800-CTRL

**Note** By default, the management port is set to DHCP.

Sections 3.1 and 3.2 provide instructions on how to convert the DHCP management port to a static IP address. If your network supports DHCP, skip sections 3.1 and 3.2.

The serial port interface enables administrators to perform management tasks on the Tdev Development Platform. You can connect to the serial port of a Tdev Development Platform, using one of the following two methods.

**Method 1: Use a male-male DB9 cross-connect cable**

1. Connect a male-male DB9 cross-connect cable between the DB9 serial port of your computer and the DB9 serial port of the TMP800-CTRL. See figure 3.1 on page 42.

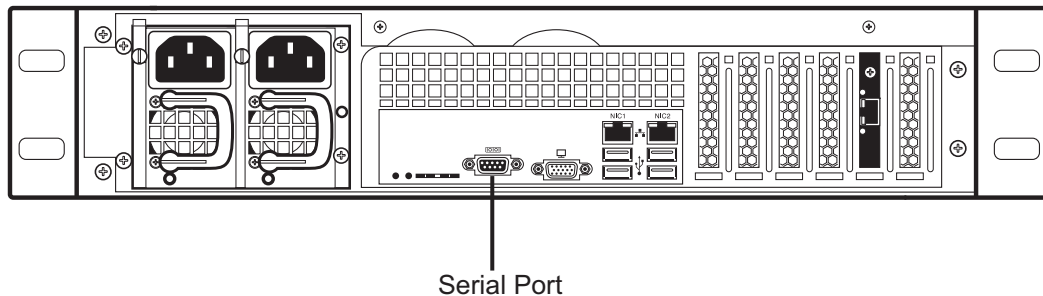

Figure 3.1 Tdev Development Platform Serial Port Connection

**Method 2: Use a USB to DB9 adapter**

1. Connect the USB connector of the cable to a USB port on your computer and the DB9 connector of the cable to the DB9 serial port of the TMP800-CTRL. See figure 3.2 on page 43.





Figure 3.2 USB to DB9 Adapter

### 3.1.2 Connecting to the Serial Port of the TMP800 Telecom Unit

The serial port interface enables administrators to perform management tasks on the TMP800 Telecom Unit.

**To connect to the serial port of a TMP800 Telecom Unit:**

1. Connect a CAT5 RJ-45 (male-male) cable (supplied with unit) between the com port of your computer and the serial port (labelled 10101) of the TMP800 Telecom Unit as shown in figure 3.3 on page 43. See Section A.2 on page 51 for a RJ-45 console wiring diagram.
2. If your computer's serial port features a DB9 connector, use the DB9 to RJ-45 adapter supplied with your TMP800 Telecom Unit. If your computer's serial port features a USB connector, you will need to provide a USB to DB9 adaptor. Refer to figure 3.2 on page 43.

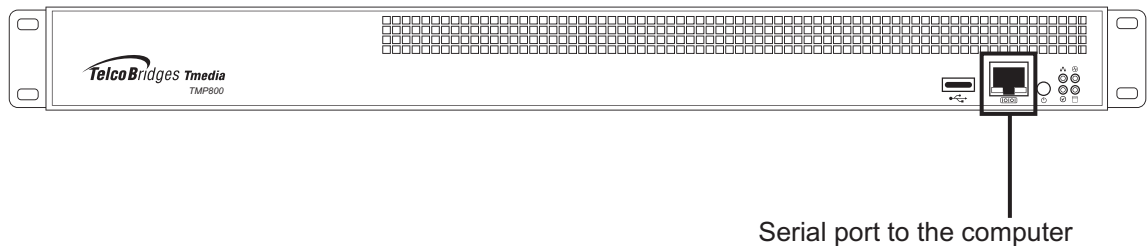

Figure 3.3 Tmedia Management Interface

## 3.2 Configuring the Terminal Emulator Application

Before initiating communication with the Tmedia serial interface, you must first configure a terminal emulator or console application to communicate with the Tdev Development Platform in order to configure initial settings. Available terminal emulation software includes:

- HyperTerminal
- Putty
- Minicom

**To configure the terminal emulator application:**

1. Set the baud rate (bits per second) to **9600**
2. Set the data rate to **8 bits**
3. Set the parity to **None**
4. Set the stop bits to **1**
5. Set the flow control to **None**

---

**Note** See Section 3.5 on page 45 to learn how to change the IP address of the MGMT0 port.

---

## 3.3 Connecting to the Tdev Development Platform

The Tdev Development Platform is shipped with the TMG-CTRL preinstalled. In order to make changes to the system configuration, you must connect the port labelled MGMT0 at the front of the Tdev Development Platform to a terminal.

To access the Tdev Development Platform, you must use an SSH connection. The password is set at the factory and is indicated on the shipment sheet.

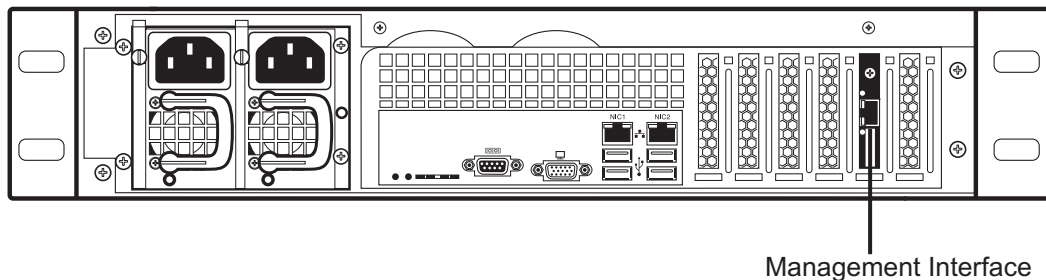

Figure 3.4 Tmedia Management Interface

## 3.4 Retrieving Tdev Development Platform Information

**Note** The Tdev Development Platform enables you to retrieve system information with the following shell commands:

- `tbproduct` (retrieve the Tmedia product type)
- `tbserial` (retrieve the Tmedia product type)

The Tdev Development Platform enables you to retrieve system information with the following shell commands:

- `tbproduct` (retrieve the Tmedia product type). See [http://docs.telcobridges.com/mediawiki/index.php/TMG:Get\\_Product\\_Type](http://docs.telcobridges.com/mediawiki/index.php/TMG:Get_Product_Type), for further information.
- `tbserial` (retrieve the Tmedia serial number). See [http://docs.telcobridges.com/mediawiki/index.php/TMG:Get\\_Serial\\_Number](http://docs.telcobridges.com/mediawiki/index.php/TMG:Get_Serial_Number), for further information.

## 3.5 Changing the Tdev Development Platform Management Port IP Address

The management port of the Tdev Development Platform (labeled MGMT0) is configured using DHCP by default. It can be modified it using the following shell script:

- `tbchangeip`. See [http://docs.telcobridges.com/mediawiki/index.php/TMG:Change\\_Management\\_IP\\_Address](http://docs.telcobridges.com/mediawiki/index.php/TMG:Change_Management_IP_Address), for further information.

## 3.6 Changing Tdev Development Platform Management Port Passwords

Once logged you are logged on to the Tdev Development Platform, type “`passwd`”, to change the password being used. The following information will be displayed:

```
[root@TB003540 ~]# passwd

Changing password for user root.
New UNIX password:
Retype new UNIX password:
passwd: all authentication tokens updated successfully.
```

## 3.7 Setting the Time Zone

You can change the time zone of the Tdev Development Platform using the `tbtimezone` shell command.

## 3.8 Configuring the Tdev Development Platform Using the Web Portal

---

**Note:** The first time that you connect to the web portal, you will need to configure the role of the TMP800-CTRL. See Section 2.5 “Start Up” on page 33

---

To change the default configuration of a Tdev Development Platform using the Web Portal, follow the steps described in the Web Portal System Configuration Tutorial Guide, found on the TBWiki:

<http://docs.telcobridges.com>

The Web Portal can be accessed with a Web browser. The default url is: `http://[Tmedia MGMT0 IP address]:12358`

---

**Note** If your system features two TMP800-CTRL units, they can access the Web Portal from either one of their IP addresses.

---

The default login information to access the Web Portal application is:

- Username: root
- Password: root

## 3.9 Changing VoIP Interface Addresses

The default address of the VoIP interfaces of the Tdev Development Platform can be modified. To learn how this is done, refer to the Web Portal tutorial guide on the Telcobridges TB Wiki at [docs.telcobridges.com](http://docs.telcobridges.com).

---

**Note** With regard to sections 3.2, 3.3, 3.4 3.5, 3.6 or 3.7, please visit the TBWiki at: <http://docs.telcobridges.com>

---

# Chapter 4      System Backups

This chapter provides information about the following topics:

- Section 4.1 “Creating a Database Backup”
- Section 4.2 “Downloading a Database Backup”
- Section 4.3 “Uploading a Database Backup”
- Section 4.4 “Restoring a Database Backup”

For more detailed information with regard to any of the points described in this section, please refer to the TBWiki: <http://docs.telcobridges.com>

## 4.1 Creating a Database Backup

It is important that backups be made of system configuration settings in the event of a system failure. It is recommended that a backup be made once the system has been configured. Backups are performed using the web portal.

## 4.2 Downloading a Database Backup

A backup of system data is stored on the hard drive of the Tdev Development Platform. It is important that system backups be downloaded to an external storage device.

## 4.3 Uploading a Database Backup

An external backup of your database can be uploaded to your Tdev Development Platform.

## 4.4 Restoring a Database Backup

In the event of a system failure requiring the replacement of a Tdev Development Platform, a previously saved backup of system settings can be restored to the new unit.

# Appendix A Wiring Diagrams

## A.1 RJ48C Wiring Diagram: Crossover and Straight Cables

**RJ 48 (T1/E1/J1) Wiring Schematic: Crossover Cable**

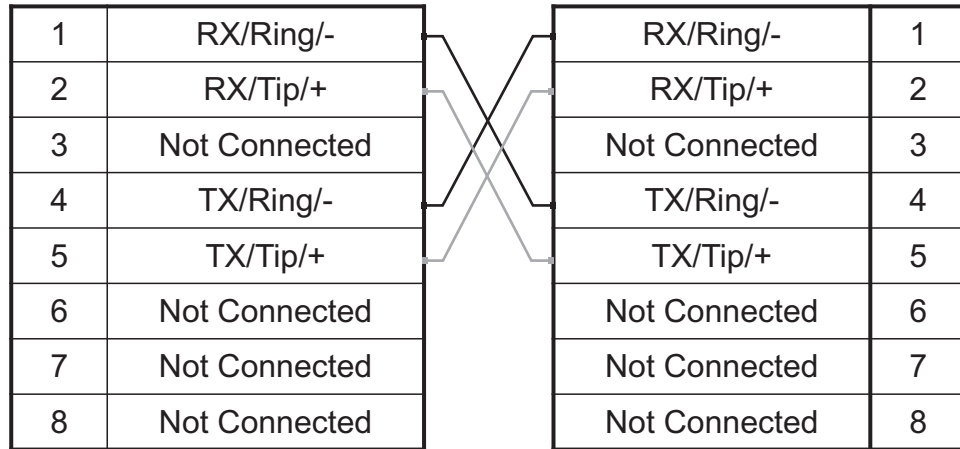

**RJ 48 (T1/E1/J1) Wiring Schematic: Straight Cable**

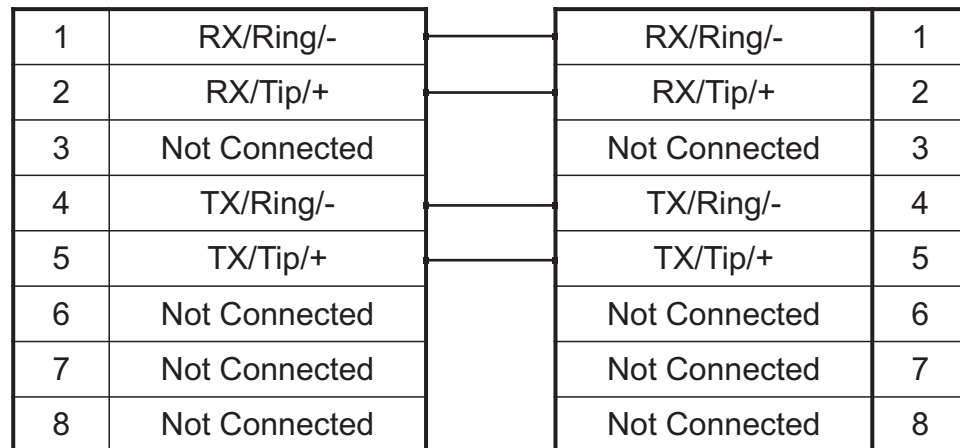



## A.2 RJ48 Console Wiring Diagram

