



Installation Guide

3200 Series Gateway Standalone & 3200 Series Gateway 1+1

August 25, 2018

The information in this document as well as product specifications referred to throughout, are subject to change without notice. No part of this document may be reproduced or transmitted in any form or by any means, electronic or mechanical, for any purpose, without the express written permission of TelcoBridges. TelcoBridges may have patents or pending patent applications, trademarks, copyrights, or other intellectual property rights covering subject matter in this document. The furnishing of this document does not give you license to these patents, trademarks, copyrights, or other intellectual property except as expressly provided in any written license agreement from TelcoBridges Inc.

The information provided in this document is intended as a guide only. For the latest detailed engineering specifications, please contact TelcoBridges TB Support or visit the TBWiki: <http://docs.telcobridges.com>. TelcoBridges is committed to continually improving product designs; as a result, product specifications may be subject to change without notification.
© 2003-2017 TelcoBridges. All rights reserved.

TelcoBridges, Tmedia, TMG800, TMG3200, TMG3200-TE, TMG3200-DS3, TMG3200-STM1, TMG7800, TMG7800-TE, TMG7800-DS3, TMG7800-STM1, TMG7800-CTRL, TMG-CONTROL, TMG7800-TMS, Tsig, TSG800, TSG3200, TSG3200-TE, TSG3200-DS3, TSG3200-STM1, Ttrans, TMGIP800, TMGIP3200, TMGIP7800, Tmedia 1+1, Tmedia N+1, TMG800+1, TMG3200-TE+1, TMG3200-DS3+1, TMG3200-STM1+1, TMG7800-TE+1, TMG7800-DS3+1, TMG7800-STM1+1, Tdev, TMP800, TMP6400, TMP6400-CTRL, TMP6400-TMS, Tmonitor, TM1000, TM3000, Toopack, Toolpack API, TB640, TB-8, TB-16, and TB-Video, are trademarks of TelcoBridges Inc. All other trademarks are the property of their owners. This information is subject to change without notice.

Issue 6.0hj

HEAD OFFICE

TelcoBridges Inc.
91 rue de la Barre, Suite 01
Boucherville, QC, J4B 2X6
CANADA
www.telcobridges.com

T +1 450 655 8993
F +1 450 655 9511
info@telcobridges.com

TB Support - Technical Support

Tel: +1 866 438 4703
support@telcobridges.com
www.telcobridges.com/en/tbsupport.aspx

Preface



About this Guide

This guide provides installation, and setup procedures for the 3200 series standalone and 3200 series 1+1 systems.

Conventions

Terminology	Description
3200 series gateway	This term is used when a description applies to both the 3200 series standalone system and 3200 series 1+1 system.
3200 series standalone system	This term is used when a description applies to the 3200 series unit operating as a standalone unit.
3200 series 1+1 system	This term is used when a description applies to the 3200 series unit operating in conjunction with the 3200 series +1. This term also includes the 1+1 patch panel(s).
3200 series unit	This term is used when a description applies to all variations of the 3200 series units, such as: TMG3200 (TMG3200-TE, TMG3200-DS3, or TMG3200-STM1), or TSG3200 (TSG3200 TSG3200-TE, TSG3200-DS3), or TMGIP3200.
3200-TE	This term is used when a description applies to the TMG3200-TE and TSG3200-TE.
3200-DS3	This term is used when a description applies to the TMG3200-DS3 and TSG3200-DS3.
3200-STM1	This term is used when a description applies to the TMG3200-STM1 and TSG3200-STM1.
3200 series +1 unit	This term is used when a description applies to all variations of the 3200 series +1 units, such as: TMG3200 +1 (TMG3200-TE, TMG3200-DS3, or TMG3200-STM1), or TSG3200 +1 (TSG3200-TE, TSG3200-DS3), or TMGIP3200 +1.
1+1 Patch Panel	This term is used as a generic reference to 1+1 patch panel(s), which enables a 3200 series to connect to a 3200 series +1.

To help guide you through the installation of your gateway, the following icons are used. Take note of the icon that represents the type of installation you are conducting and follow it throughout this guide to ensure proper installation and gateway setup.

Graphics	Description
	<p>This icon appears in the margins of pages describing the 3200 series operating as a standalone unit. If you are installing a standalone unit read and follow the instructions provided in those sections and pages.</p>
	<p>This icon appears in the margins of pages describing the 3200 series operating in conjunction with a 3200 series +1 and 1+1 Patch Panel(s). If you are installing a 1+1 System read and follow the instructions provided in those sections and pages.</p>

Contact Us

If you have comments about this guide or any other TelcoBridges technical documentation, please send an email to marketing@telcobridges.com.

Table of Contents

Section 1	Introduction.....	1
1.1	Recognizing a 3200 Series Standalone versus a 3200 Series 1+1 System	2
1.1.1	3200 Series Standalone	2
1.1.2	3200 Series 1+1 System	2
1.1.3	Product Images	2
1.2	Installation Prerequisites	4
1.3	Preventing Electrostatic Discharge Damage.....	5
1.4	Recommended Reading.....	6
Section 2	Installing the Equipment	7
2.1	Package Contents	8
2.1.1	3200 Series Standalone Package Contents.....	8
2.1.2	3200 Series 1+1 System Package Contents.....	9
2.2	Rack Mounting the 3200 Series Standalone or 3200 Series 1+1 System	11
2.2.1	Prerequisites	11
2.2.2	Vertical Placement of the Equipment	11
2.2.3	Installing the 3200 Series Standalone and the 3200 Series 1+1 on an Equipment Rack ..	11
2.3	Choosing your Connection Procedures.....	13
2.4	3200 Series Standalone System	14
2.4.1	Connecting to the 3200 Series Gateway Management Interface.....	15
2.4.2	Connecting to a VoIP Network	16
2.4.3	Connecting to the PSTN.....	17
2.4.3.1	SCSI Interface (T1/E1) for the 3200-TE	18
2.4.3.2	Dual BNC Interface (DS3) for the 3200-DS3.....	20
2.4.3.3	Optical Interface (OC3/STM-1) for the 3200-STM1.....	21
2.4.4	Grounding the Equipment Chassis.....	22
2.4.5	Powering Up.....	23
2.4.5.1	Connecting to AC Power	23
2.4.5.2	Connecting to DC Power	24
2.4.6	Start Up	25
2.4.6.1	Configuring the Role.....	25
2.5	3200 Series 1+1 System	26
2.5.1	Connecting to the 3200 Series 1+1 System Management Interfaces	27
2.5.2	Connecting to the Control Network	28
2.5.3	Connecting the 3200 Series 1+1 System VoIP Network(s).....	29
2.5.4	Connecting to the PSTN in a 3200 Series 1+1 System	30
2.5.4.1	SCSI Interface (T1/E1) for the 3200-TE and 3200-TE+1	31
2.5.4.2	Dual BNC Interface (DS3) for the 3200-DS3 and 3200-DS3+1	33
2.5.4.3	Optical Interface (OC3/STM-1).....	34
2.5.5	Grounding the Equipment Chassis.....	36
2.5.6	Powering Up.....	37
2.5.6.1	Connecting to AC Power	37
2.5.6.2	Connecting to DC Power.....	38
2.5.7	Start Up	39
2.6	Add a 3200 Series +1 Unit to a Standalone, Creating a 3200 Series 1+1 System	41

2.6.1	Reconfigure a Standalone Unit as a Primary Unit in an 3200 Series 1+1 System.....	41
2.6.2	Install the 3200 Series +1 Unit on the Equipment Rack.....	44
2.6.3	Install a 1+1 Patch Panel	44
2.6.4	Connect to the 3200 Series 1+1 Management Interface.....	45
2.6.5	Connect to the 3200 Series 1+1 Control Network.....	45
2.6.6	Connect to the VoIP Network.....	45
2.6.7	Connect to the PSTN Network	46
2.6.8	Grounding the Equipment Chassis.....	46
2.6.9	Power Up the 3200 Series 1+1 System	47
2.6.10	Start Up	48
2.7	Verifying the LED Status Indications	49
2.8	Powering Down	50
2.8.1	Local Method.....	50
2.8.2	Remote Method.....	50
Section 3	Initial System Configuration.....	51
3.1	3200 Series Gateway SSH Connection	52
3.2	3200 Series Gateway Serial Connection.....	52
3.2.1	Physical Connection.....	52
3.2.1.1	Connecting to the USB Port of the 3200 Series Gateway.....	53
3.2.1.2	Connecting to the Serial Port of the 3200 Series Gateway	53
3.2.2	Configuring the Terminal Emulator Application	54
3.3	Changing 3200 Series Gateway Management Port Passwords	55
3.4	Retrieving 3200 Series Gateway Information.....	55
3.5	Changing the 3200 Series Gateway Management Port IP Address	55
3.6	Setting the Time Zone	56
3.7	Configuring the 3200 Series Gateway Using the Web Portal.....	56
3.8	Changing VoIP Interface Addresses	56
Section 4	System Backups.....	57
4.1	Creating a Database Backup	58
4.2	Downloading a Database Backup	58
4.3	Uploading a Database Backup.....	58
4.4	Restoring a Database Backup.....	58
Appendix A	Wiring Diagrams.....	59
A.1	RJ48C Wiring Diagram: Crossover and Straight Cables.....	60
A.2	Tmedia Serial Adapter Wiring Diagram.....	61



Section 1 Introduction

This chapter provides an introduction to the installation and setup for the following configurations:



3200 Series Standalone: Single gateway unit operation in standalone mode.



3200 Series 1+1 System: 3200 series unit operating in conjunction with a 3200 series +1 unit, and 1+1 patch panel(s).

Note 1+1 Patch panels are only available for the TMG3200 and TSG3200.

The following topics are covered:

- Section 1.1 “Recognizing a 3200 Series Standalone versus a 3200 Series 1+1 System”
- Section 1.2 “Installation Prerequisites”
- Section 1.3 “Preventing Electrostatic Discharge Damage”
- Section 1.4 “Recommended Reading”



1.1 Recognizing a 3200 Series Standalone versus a 3200 Series 1+1 System



1.1.1 3200 Series Standalone

The 3200 series standalone consists of one telecom unit. The front and rear views are shown in figure 1.1 on page 2.

1.1.2 3200 Series 1+1 System

The 3200 series 1+1 system, see figure 1.1 on page 2 and figure 1.2 on page 3, consists of:

- One telecom unit
- One +1 telecom unit
- One or two 1+1 patch panels

1.1.3 Product Images

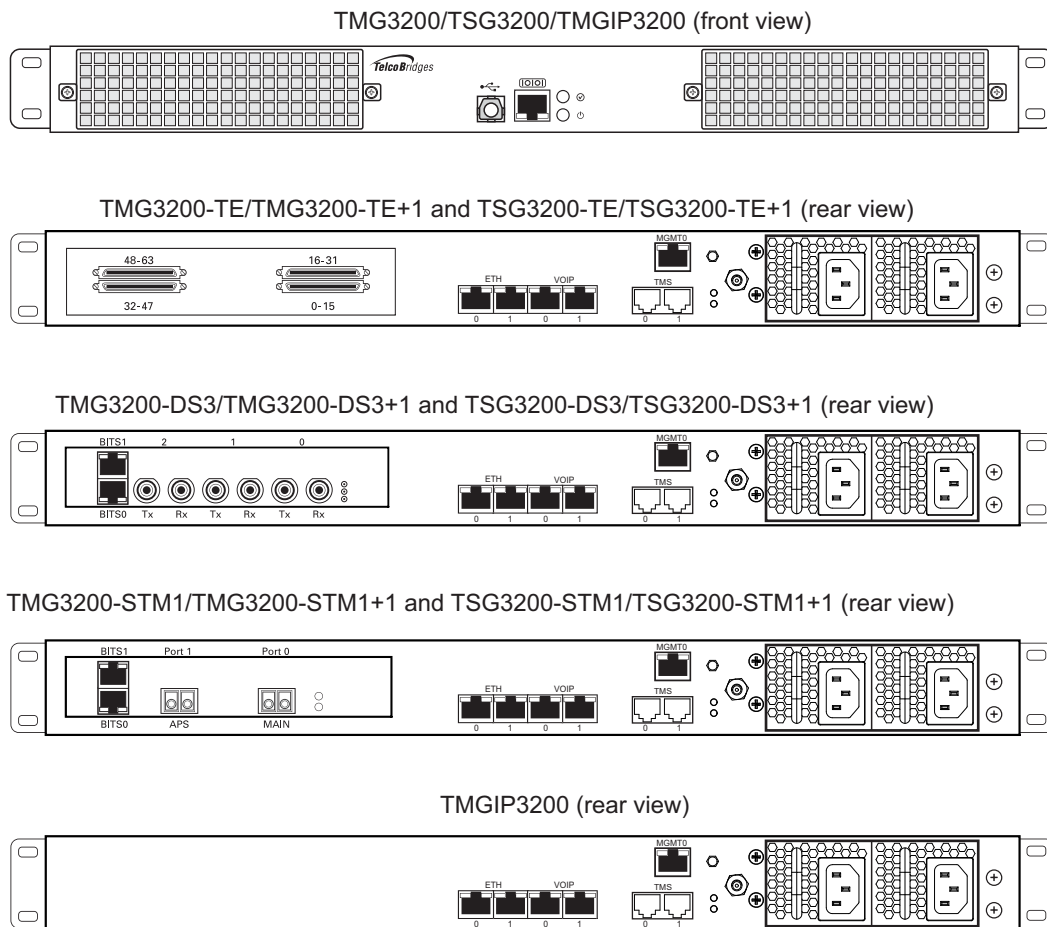

Figure 1.1 3200 Series and 3200 Series +1 (Front and Rear Views)

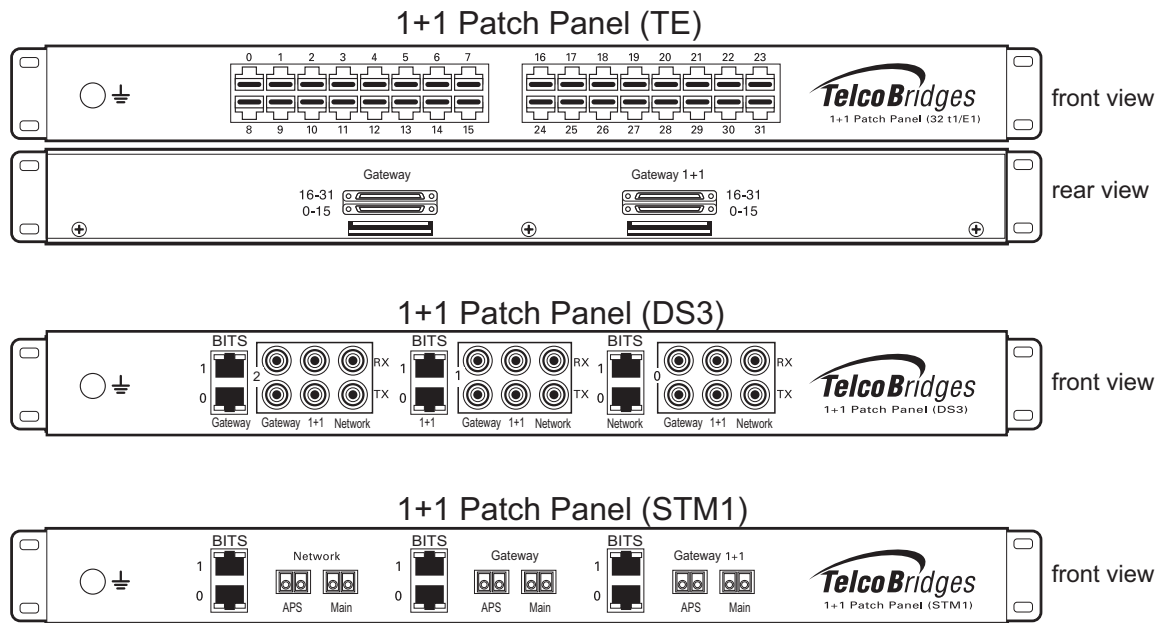

Figure 1.2 1+1 Patch Panels (Front and Rear Views)





1.2

Installation Prerequisites

For the installation to proceed without interruption, it is important that you verify that you have all necessary materials on hand.



 3200 Series Standalone	 3200 Series 1+1 System								
<p>Adequate space for the installation of the 3200 Series Standalone. You will need to mount the 3200 series unit on a 19" equipment rack (customer provided). Your 3200 series unit is a 1U unit.</p> <p>Adequate power supply and power connections. The 3200 series unit requires two power connections to provide for its redundant power supply.</p> <p>To guarantee an uninterrupted supply of electricity, each power connection must be fed by a dedicated power source.</p> <p>An IP address for the management port. To avoid delays, you should have the IP address, netmask and gateway addresses on hand. Take note that the management port supports DHCP, see Section 2.4.1 "Connecting to the 3200 Series Gateway Management Interface" on page 15 for further information.</p>	<p>Adequate space for the installation of your 3200 Series 1+1 system. You will need to mount the 3200 series 1+1 system on a 19" equipment rack (customer provided).</p> <p>Your 1+1 System requires space for the following number of units:</p> <table data-bbox="922 793 1312 928"> <tr> <td>3200 Series Unit:</td> <td>1U</td> </tr> <tr> <td>3200 Series +1 Unit:</td> <td>1U</td> </tr> <tr> <td>1+1 Patch Panel:</td> <td>1U or 2U^a</td> </tr> <tr> <td>Total:</td> <td>3U or 4U^b</td> </tr> </table> <p>Adequate power supply and power connections. The 3200 series and 3200 series +1 units require two power connections each, as they are equipped with redundant power supplies. To guarantee an uninterrupted supply, each power connection must be fed by a dedicated power source.</p> <p>An IP address for the management port. To avoid delays, you should have the IP address, netmask and gateway addresses on hand. Take note that the management port supports DHCP, see Section 2.5.1 "Connecting to the 3200 Series 1+1 System Management Interfaces" on page 27 for further information.</p>	3200 Series Unit:	1U	3200 Series +1 Unit:	1U	1+1 Patch Panel:	1U or 2U ^a	Total:	3U or 4U ^b
3200 Series Unit:	1U								
3200 Series +1 Unit:	1U								
1+1 Patch Panel:	1U or 2U ^a								
Total:	3U or 4U ^b								

a. 1U per 1+1 patch panel, 2U if two patch panels are required

b. Depending on whether your system required 1 or 2 patch panels. Refer to Section 2.1.2 "3200 Series 1+1 System Package Contents"

1.3 Preventing Electrostatic Discharge Damage

Electrostatic discharge (ESD) can damage equipment and impair electrical circuitry. It may occur if electronic printed circuit cards are improperly handled and may cause complete or intermittent failure.



Warning

Always follow ESD prevention procedures when removing and replacing modules:

- Ensure that the gateways are grounded.
- Wear an ESD-preventive wrist strap and ensure that it makes good contact with your skin. Connect the wrist strap clip to an unpainted surface of the equipment or the grounded equipment rack in order to channel away all ESD voltage safely to ground. To guard against ESD damage and shocks, the wrist strap and cord must be in proper working condition.
- If no wrist strap is available, and you must work with the equipment, ground yourself by touching a metal part of the chassis.

1.4 Recommended Reading

This document assumes that you have a clear understanding of the installation of the equipment described in this document and have been trained to work with the equipment. If you have any technical questions, TelcoBridges TB Support (technical support team) can be reached at the following numbers or an email can be sent to: support@telcobridges.com.

- Americas & Europe Technical Support Centre (GMT-05:00, Montreal):
Telephone: +1-450-655-8993 x131 or x102
- Asia Technical Support Centre (GMT +08:00, Hong Kong)
Telephone: +852-3749-9818
- 24/7 International Support
Telephone: +1-866-438-4703

Documents exploring various aspects of the product are available on the TB Wiki:
<http://docs.telcobridges.com>



Section 2 Installing the Equipment

This chapter provides information about the following topics:

- Section 2.1 “Package Contents”
- Section 2.2 “Rack Mounting the 3200 Series Standalone or 3200 Series 1+1 System”
- Section 2.3 “Choosing your Connection Procedures”
- Section 2.4 “3200 Series Standalone System”
- Section 2.5 “3200 Series 1+1 System”
- Section 2.6 “Add a 3200 Series +1 Unit to a Standalone, Creating a 3200 Series 1+1 System”
- Section 2.7 “Verifying the LED Status Indications”
- Section 2.8 “Powering Down”



2.1 Package Contents

Depending on your system requirements, you may receive one or more of the following items:

- Section 2.1.1 “3200 Series Standalone Package Contents” on page 8.
- Section 2.1.2 “3200 Series 1+1 System Package Contents” on page 9.
- Section “1+1 Patch Panels” on page 10.

The contents of these devices are described in the following sections.

2.1.1 3200 Series Standalone Package Contents

TMG3200, TSG3200, TMGIP3200

In the box, you will find the following items:

- One 3200 series unit:
TMG3200 (TMG3200-TE, TMG3200-DS3, or TMG3200-STM1), or TSG3200 (TSG3200-TE, TSG3200-DS3), or TMGIP3200. See figure 1.1 on page 2.
- One set of mounting brackets and screws, used to mount the 3200 series unit to a 19" rack.
- One DB-9 to RJ-45 adapter to interface the serial port of your computer with the RJ-45 port of the 3200 series unit.
- Three CAT5 Ethernet (blue) straight cables (male-male), 3 meters in length.
- One Important Notice (two-sided document containing pertinent product serial numbers, and other important information).
- One Product Warranty.
- One packing slip.
- Two AC power cables

Specifically with the 3200-TE unit, you will also have:

- One or two patch panel(s)
- Two SCSI cables per patch panel.

Not included

- A 19" equipment rack. The 3200 series unit must be installed on a 19" wide equipment rack.

2.1.2 3200 Series 1+1 System Package Contents

TMG3200, TSG3200, TMGIP3200

In the box, you will find the following items:

- One 3200 series unit:
TMG3200 (TMG3200-TE, TMG3200-DS3, or TMG3200-STM1), or TSG3200 (TSG3200-TE, TSG3200-DS3), or TMGIP3200. See figure 1.1 on page 2.
- One set of mounting brackets and screws, used to mount the 3200 series unit to a 19" rack.
- One DB-9 to RJ-45 adapter to interface the serial port of your computer with the RJ-45 port of the 3200 series unit.
- Three CAT5 Ethernet (blue) straight cables (male-male), 3 meters in length.
- One Important Notice (two-sided document containing pertinent product serial numbers, and other important information).
- One Product Warranty.
- One packing slip.
- Two AC power cables

For patch panel information, see Table 2.1, "1+1 Patch Panels", on page 10:

Not included

- A 19" equipment rack. The 3200 series unit must be installed on a 19" wide equipment rack.

TMG3200 +1, TSG3200 +1, TMGIP3200 +1

In the box, you will find the following items:

- One 3200 +1 series unit:
TMG3200 +1 (TMG3200-TE, TMG3200-DS3, or TMG3200-STM1), or TSG3200 +1 (TSG3200-TE, TSG3200-DS3), or TMGIP3200 +1. See figure 1.1 on page 2.
- One set of mounting brackets and screws, used to mount the 3200 +1 series unit to a 19" rack.
- One DB-9 to RJ-45 adapter to interface the serial port of your computer with the RJ-45 port of the 3200 + 1 series unit.
- Three CAT5 Ethernet (blue) straight cables (male-male), 3 meters in length.
- One Important Notice (two-sided document containing pertinent product serial numbers, and other important information).
- One Product Warranty.
- One packing slip.
- Two AC power cables

For patch panel information, see Table 2.1, "1+1 Patch Panels", on page 10:



Not included

- A 19" equipment rack. The 3200 +1 series unit must be installed on a 19" wide equipment rack.



1+1 Patch Panels

1+1 patch panels are required for the proper connection of the 3200 series 1+1 system, and are automatically included when a 3200 +1 series unit is ordered. Table 2.1 lists the various 1+1 patch panels that you will receive based upon the type of 3200 series telecom unit integrated in your 3200 series 1+1 system.

Table 2.1 1+1 Patch Panels

<p>1+1 Patch Panel (32/T1/E1)</p>	<p>Provides connection for up to 32 T1/E1 lines from the network to the 3200-TE and 3200-TE+1.</p> <p>To connect the 3200-TE-16 and the 3200-TE-32 to their respective +1 units and the network, you will required one 1+1 Patch Panel (32 T1/E1).</p> <p>To connect the 3200-TE-48 and the 3200-TE-64 to their respective +1 units and the network, you will require two 1+1 Patch Panel (32 T1/E1).</p> <p>Cables provided:</p> <p>4 SCSI straight cables per 1+1 Patch Panel (32 T1/E1). Three meters in length. This provides connection for up to 32 lines.</p>
<p>1+1 Patch Panel (DS3)</p>	<p>Provides connection for up to 3 DS3 lines from the network to the 3200-DS3 and 3200-DS3+1.</p> <p>Cables provided (with each 1+1 Patch Panel (DS3)):</p> <ul style="list-style-type: none"> • 4 DS3 cables, each two meters in length, are shipped for each DS3 that is ordered. (4, 8, or 12 cables) • 4 RJ48C straight cables (yellow), two meters in length.
<p>1+1 Patch Panel (STM1)</p>	<p>Provides connection of 1 STM1 line from the network to the 3200-STM1 and 3200-STM1+1.</p> <p>Cables provided (with each 1+1 Patch Panel (STM1)):</p> <ul style="list-style-type: none"> • 4 pairs of fiber optic cables, two meters in length. • 4 RJ48C straight cables (yellow), two meters in length.

2.2 Rack Mounting the 3200 Series Standalone or 3200 Series 1+1 System

The 3200 series equipment is mounted on a customer provided equipment rack using the mounting hardware packaged in the box.



2.2.1 Prerequisites

To rack mount the equipment, you will need:

- One 19" customer-provided equipment rack. The rack must be solidly anchored to the floor with appropriate support at the top of the racks.
- Climate controlled room: 0 to +50 Celsius, 0 to 95% non-condensing humidity.

2.2.2 Vertical Placement of the Equipment

The 3200 series standalone and 3200 series +1 are each housed in a 1U chassis, as tabulated in table 2.2 on page 11. It is important that you provide for enough room on the equipment rack to allow for the installation of the equipment.

Consider the available space on your equipment rack and the height of the 3200 series gateway equipment. Due to the rear-exhaust heat vents and the efficient heat dissipation design, there is no need to leave any physical vertical space above or below the 3200 series gateway equipment on the rack.

Table 2.2 3200 Series Gateway Physical Height

3200 Series	Vertical Height
3200 series standalone	1U (1.75 inches or 44.45 mm)
3200 +1 series	1U (1.75 inches or 44.45 mm)
Patch Panels	1U (1.75 inches or 44.45 mm)

2.2.3 Installing the 3200 Series Standalone and the 3200 Series 1+1 on an Equipment Rack

Both the 3200 series standalone and the 3200 series 1+1 system are mounted on the 19" equipment rack using the angle brackets and screws provided in the box.



Mounting the 3200 Series Standalone:

1. Using four metal screws, attach one angle bracket to the front, left-hand side of the 3200 series unit, when viewed from the front, as shown in figure 2.1 on page 12. Do the same for the angle bracket on the right-hand side.
2. Start mounting equipment at the top-most position of the rack, keeping in mind the space required on the equipment rack as described in Section 2.2.2 "Vertical Placement of the Equipment" on page 11.



Mounting the 3200 Series 1+1 System:

1. Mount the 3200 series unit as mentioned above.
2. Install the 3200 series +1 unit below the 3200 series unit, as shown in figure 2.1 on page 12.
3. Install the patch panel below the 3200 series +1 unit, as shown in figure 2.1 on page 12.

3200 Series Standalone

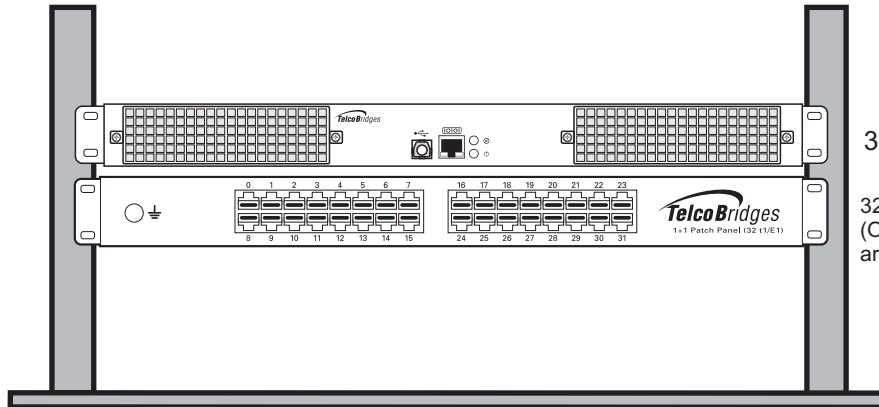

3200 Series Unit

3200-TE patch panel shown
(Other patch panels are available)

3200 Series 1+1 System

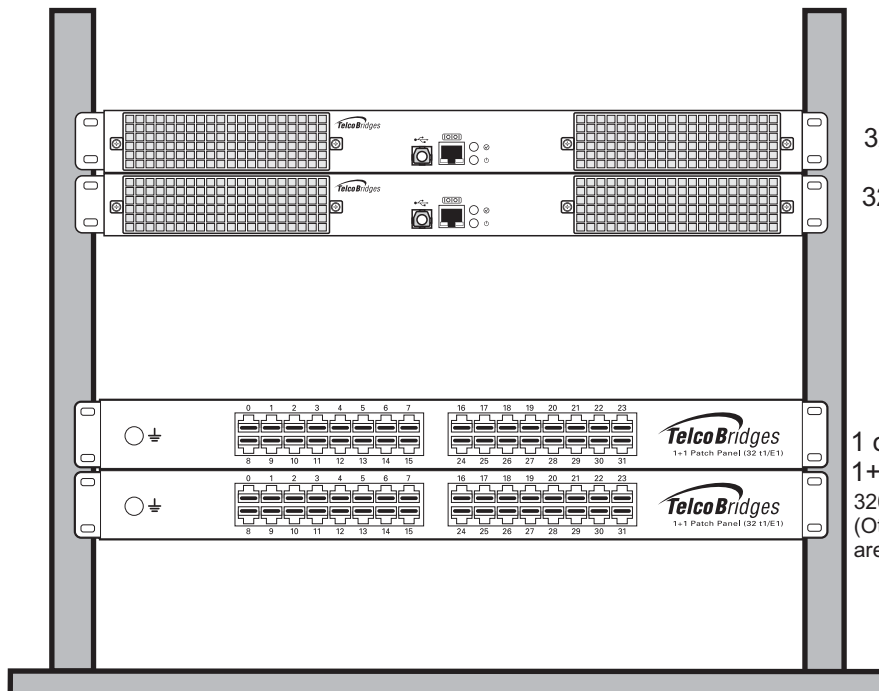

3200 Series Unit

3200 Series +1

1 or 2
1+1 Patch Panels
3200-TE patch panel shown
(Other patch panels are available)

Figure 2.1 Rack mounting the Equipment

2.3 Choosing your Connection Procedures

Use the following diagram to guide you to the appropriate section, based on your chosen installation.

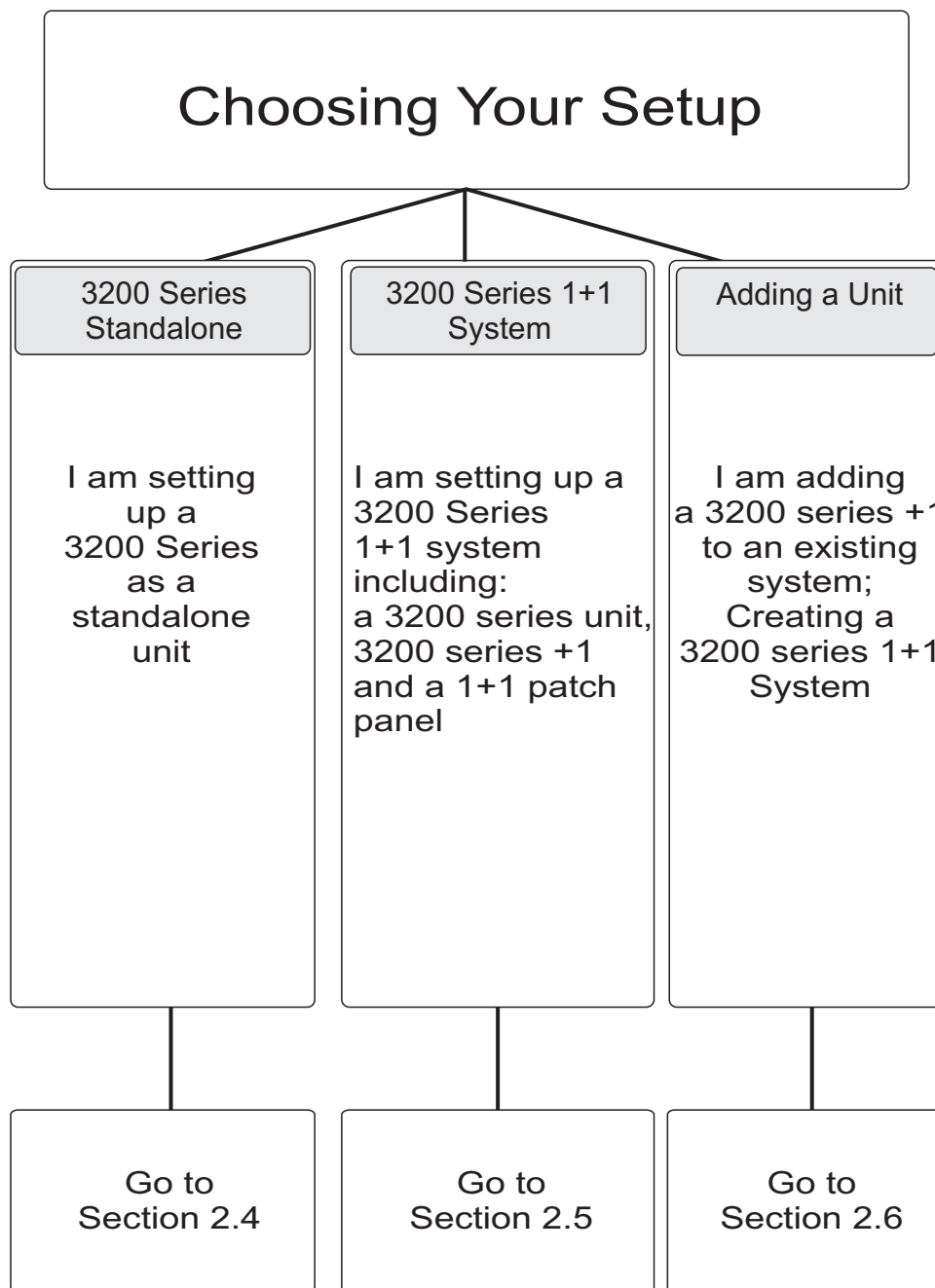



2.4

3200 Series Standalone System

If you are here, you have a 3200 series unit that you will setup as a standalone system. This section covers the following procedures for a 3200 series standalone system:



- Section 2.4.1 "Connecting to the 3200 Series Gateway Management Interface".
- Section 2.4.2 "Connecting to a VoIP Network".
- Section 2.4.3 "Connecting to the PSTN".
- Section 2.4.4 "Grounding the Equipment Chassis".
- Section 2.4.5 "Powering Up".
- Section 2.4.6 "Start Up".

2.4.1 Connecting to the 3200 Series Gateway Management Interface

The 3200 series gateway management interface enables administrators to perform management tasks on the 3200 series unit.



Prerequisites

To communicate with the management interface, the following is needed:

- One CAT5 Ethernet cable with RJ45 male-male terminations.

Interconnections

The 3200 series gateway provides a management interface, using one gigabit Ethernet network link, as shown in figure 2.2 on page 15.

To communicate with the management interface:

1. Connect the supplied CAT5 Ethernet cable to the port labeled “MGMT0” at the rear of the 3200 series gateway.

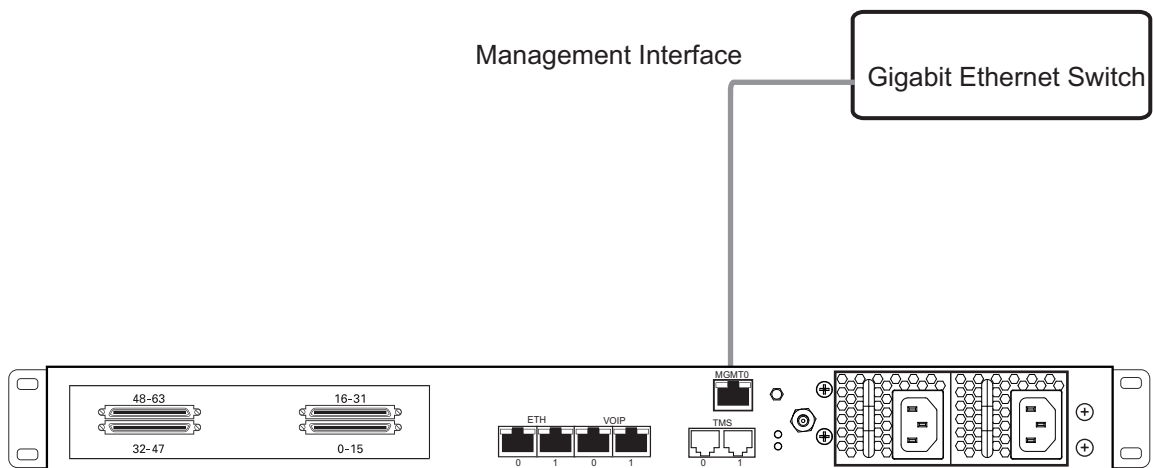

Figure 2.2 Management Interface



2.4.2

Connecting to a VoIP Network

The 3200 series gateway features dual GigE ports for connection to different VoIP networks. This provides an access point to manage VoIP traffic. Should one of the IP networks fail, the 3200 series gateway will continue to manage VoIP traffic using the alternate network.

The IP address of the VoIP ports can be modified using the web portal.

Note: Certain configurations of the 3200 series gateway will exceed 100 Mbps, therefore 1000 Mbps is recommended.

Prerequisites

To connect the 3200 series gateway to the VoIP network, you will need:

- Gigabit layer 2 Ethernet switch. A second one is required to support redundancy of the VoIP interface.
- One or two CAT5 Ethernet cables with RJ45 male-male terminations.
- If your system has access to a second VoIP network, you can connect it to a second VoIP interface of the 3200 series gateway with an RJ45 (male-male) CAT5 Ethernet cable.

Connections

The 3200 series gateway is connected to the VoIP network by one or optionally two Ethernet GigE network links, as shown in figure 2.3 on page 16.

To connect to the VoIP network:

1. Connect a CAT5 Ethernet cable to VoIP0 at the rear of the 3200 series gateway. Connect the other end of the same CAT5 cable to the Gigabit Ethernet switch.
2. If your system employs a second Gigabit Ethernet switch for redundancy, connect a second CAT5 Ethernet cable to VoIP1 at the rear of the 3200 series gateway. Connect the other end of the same CAT5 cable to the second Gigabit Ethernet switch.

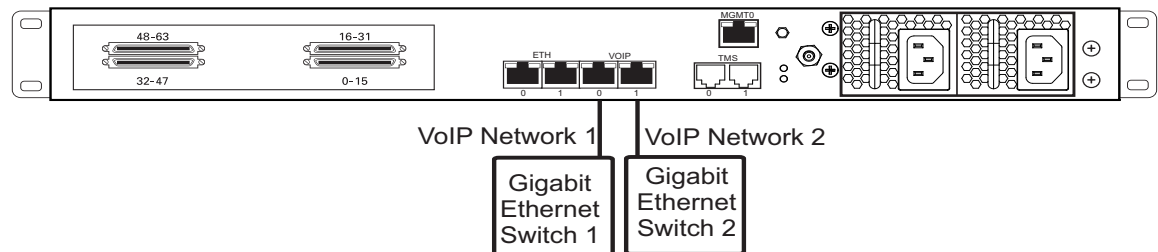

Figure 2.3 Connecting to the VoIP Network

2.4.3 Connecting to the PSTN

The 3200 series gateway features a variety of interfaces to the PSTN network.



Note This section only applies to the TMG3200 and TSG3200 systems.

Prerequisites

To connect to the PSTN network, you must comply with one of the following:

- Your 3200-TE features SCSI connectors that in turn connect to an SCSI patch panel to terminate in RJ48C connectors for connection to T1/E1 lines. You will require one patch panel for each 32-line grouping of T1/E1 line interfaces.
- Your 3200-DS3 features BNC connectors for connection to DS3 lines. You will require two coaxial cables for each DS3 interface.
- Your 3200-STM1 features electrical or optical STM-1 connectors. You will require two fiber optic cables for each STM-1 interface.



2.4.3.1

SCSI Interface (T1/E1) for the 3200-TE

A 3200-TE and SCSI patch panel enables the connection to T1/E1 lines. The termination impedance is set at 120 ohms. It is possible to connect an external balun in order to convert to 75 ohms.

Note

All ports may not be active. T1/E1 ports are activated by software license; the number of active ports depends on the licenses purchased.

Patch panels use straight connections. In other words, they do not cross the RX and TX signals. Connections between the patch panels and the 3200 series gateway require straight cables. The supplied SCSI cables are straight cables. Cables used to connect the network to the patch panel must do the cross connection.

To connect the 3200-TE to the PSTN:

1. Start with SCSI ports 0-15 located at the bottom right as shown in figure 2.4 on page 19. Connect one SCSI cable between this port and SCSI patch panel number 1, ports 0-15. Connect SCSI ports 16-31 to patch panel number 1, ports 16-31.
2. Repeat step 1, using lines 32-63 and a second patch panel. Connect lines 32-47 to patch panel 2, ports 0-15. Connect lines 48-63 to patch panel 2, ports 16-31.

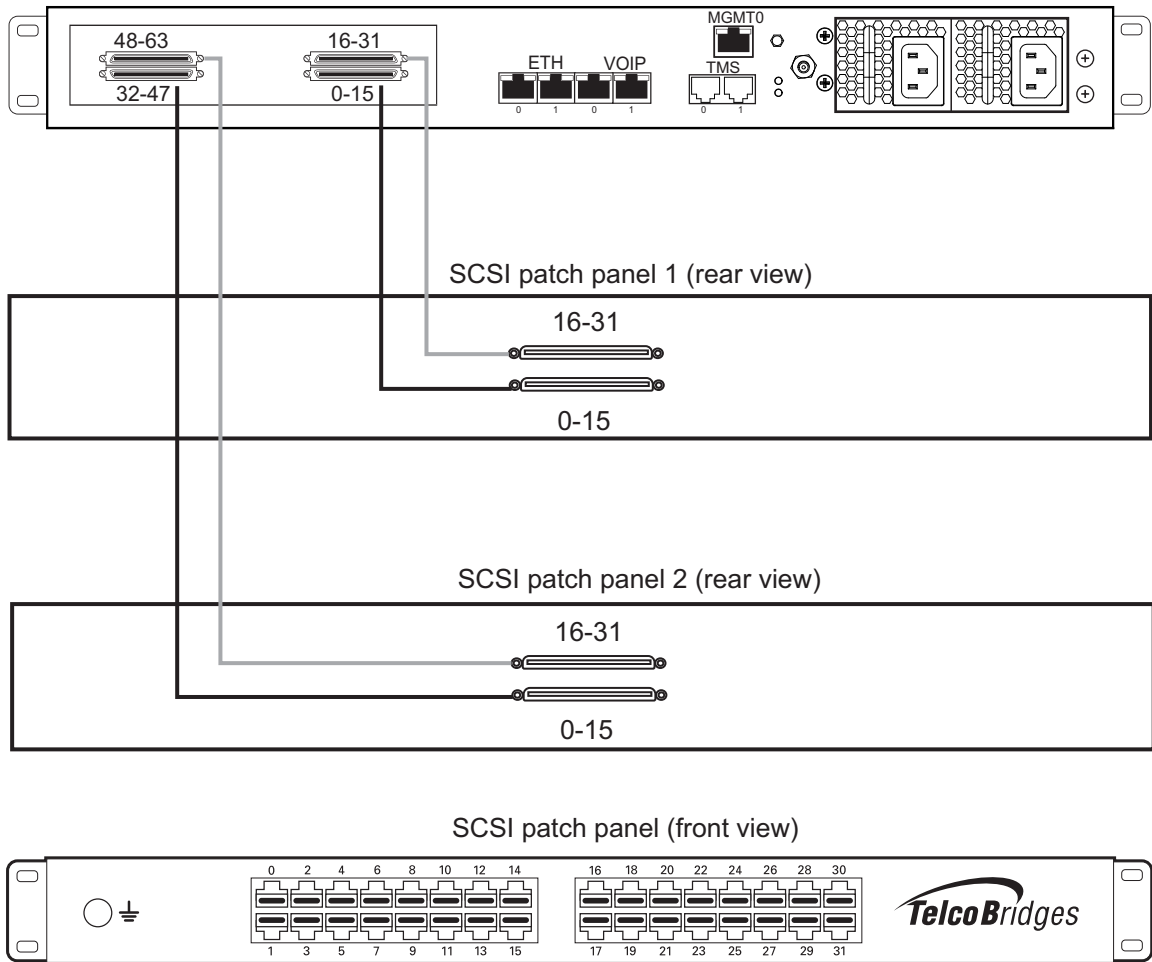

Figure 2.4 3200-TE with SCSI connectors



2.4.3.2

Dual BNC Interface (DS3) for the 3200-DS3

A 3200-DS3 with 3 sets of BNC connectors enables the connection to DS3 lines. See figure 2.5 on page 20.

Note All ports may not be active. DS3 ports are activated by software license; the number of active ports depends on the licenses purchased.

To connect the 3200-DS3 to the PSTN:

1. Start with the Dual BNC port pair #0 (right-most) as shown in figure 2.5 on page 20. Connect one pair of BNC cables between this port and the DS3 line.
2. Repeat step 1, using the next available pair of BNC PSTN interface ports.
3. Connect to the BITS Interface using BITS or SS7 links.

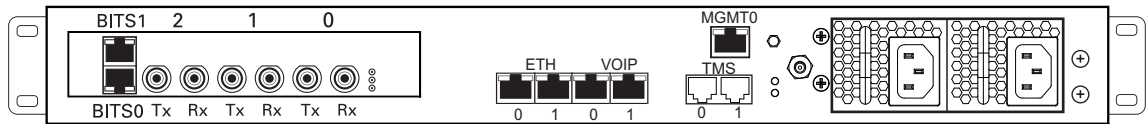

Figure 2.5 3200-DS3 Interface to the PSTN



2.4.3.3 Optical Interface (OC3/STM-1) for the 3200-STM1

A 3200-STM-1, with one main and one backup OC3 or STM1 port enables connection to OC3/STM1 lines. See figure 2.6 on page 21. Refer to table 2.3 on page 21 for a listing of optical interfaces. The default SFP module for OC3/STM1 connection is SMF, intermediate reach, (SFP-OC3-IR1) 1310 nm with LC type connectors.

Note Please make certain that the correct SFP model is selected at the time of ordering. If your installation requires a different model from the one that has been provided, you must replace it.

Table 2.3 Optical Interfaces

Transceiver Model	Description	Spec	Mode	Type	Range (Km.)	Wavelength (NM)	Connection
SFP-OC3-IR1	OC3/STM1	Hot Pluggable	Single-mode	Intermediate reach	15	1310	LC
SFP-STM1E	STM1E (Electrical)	Hot Pluggable	75 ohms Cooper	Max 180m	1	NA	DIN (mini-coax)

Automatic Protection Switching

The APS port is used for OC3/STM1 redundancy. Switchover occurs automatically based on configurable parameters. It is recommended that APS be used if the installation provides this feature.

To connect the 3200-STM1 (Optical Interface) to the PSTN:

1. Connect a fiber optic cable between the Port 0 (Main) port and OC3/STM1 line, as shown in figure 2.6 on page 21.
2. Connect a second fiber optic cable between the Port 1 (APS) port and OC3/STM1 line.

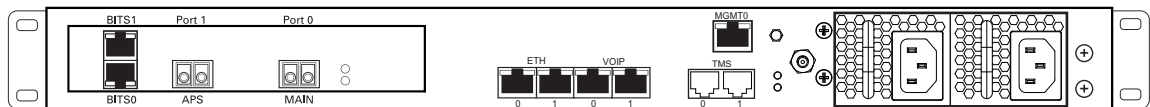

Figure 2.6 3200-STM1 Optical Interface to the PSTN



2.4.4

Grounding the Equipment Chassis

As a standard safety practice, the chassis of the 3200 series gateway must be properly grounded to protect against any contact with an electrical fault condition. It is recommended that the chassis be connected to an earth ground. When the 3200 series gateway is installed in an equipment rack, connect the ground wire between the ground lug of the gateway and the equipment rack ground bar. If more than one 3200 series gateway is installed in an equipment rack, each 3200 series gateway must be grounded directly to the equipment rack ground bar.

Guidelines

- Use 10 AWG (minimum) stranded ground wire.
- Terminate equipment side of ground wire with a #10 ring terminal.
- Keep the length of the ground wire as short as possible.
- Do NOT daisy chain the ground between equipment. Use a ground bus bar, as show in figure 2.7 on page 22.
- Do not over tighten ground lug connections.

To connect to the 3200 series gateway to ground:

1. Connect one end of a ground wire to the ground lug of the 3200 series gateway (AC or DC model). See figure 2.7 on page 22.
2. Connect the other end of the ground wire to a ground bar of the equipment rack. If the 3200 series gateway is not installed in an equipment rack, connect the ground wire to earth ground.

In the case of DC powered units, connect an additional ground wire from the chassis ground terminal of each DC supply.

3. Verify that the resistance of the ground path is less than 0.5 ohms.

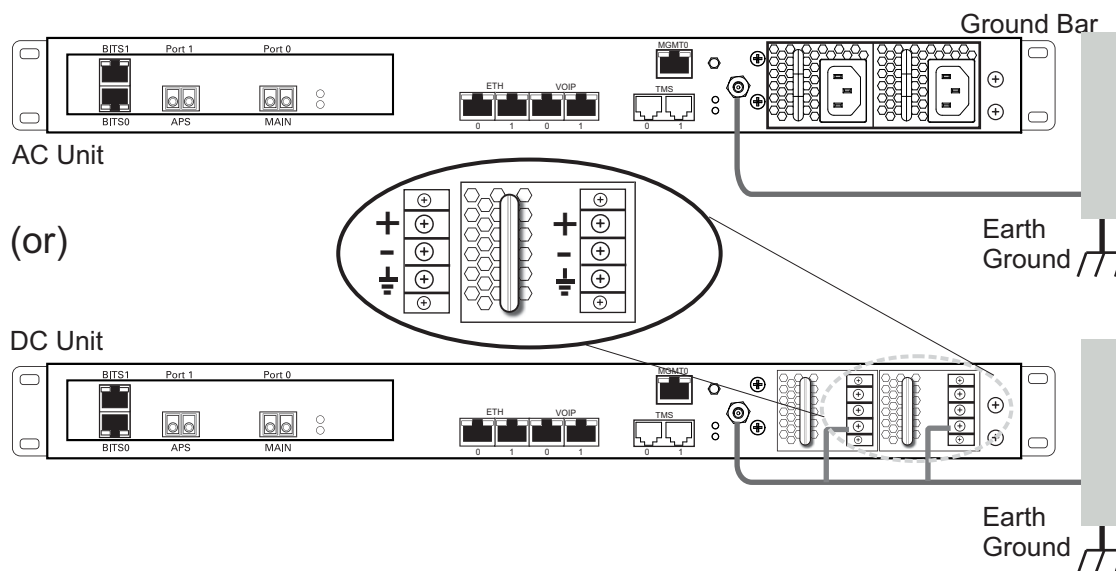

Figure 2.7

Chassis Ground Connection



2.4.5 Powering Up

The 3200 series gateway is furnished with two AC or DC power connections. Only once all other equipment installation work has been completed should the 3200 series gateway be powered up.

2.4.5.1 Connecting to AC Power

Prerequisites

To power the 3200 series gateway, you will need:

- One to two power sources (138W).
- Two power cables for the 3200 series gateway.

The 3200 series gateway AC model is furnished with two AC power connectors.

To connect to AC Power:

1. Connect an AC power cable between the AC connector of the 3200 series gateway and an AC supply. See figure 2.8 on page 23.

Note It is important to connect both power supplies in order to avoid setting off the audible alarm.

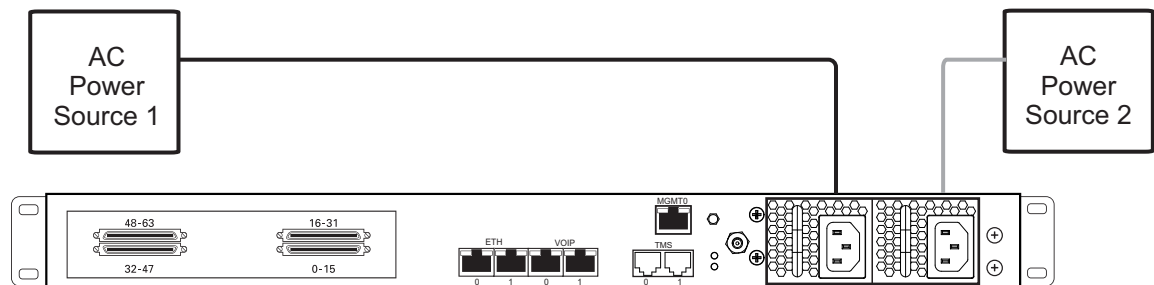

Figure 2.8 3200 Series Gateway AC Power Connection



2.4.5.2

Connecting to DC Power

The 3200 series gateway DC model is furnished with two DC power connection ports. In addition, each DC powered unit is supplied with two DC power cables.

Fuse and Cabling Requirements

16 AWG wiring must be used and the 48V supply must be protected with a customer provided 5A 48V fuse.

To connect o DC power:

1. Connect one wire from the positive terminal of the 3200 series gateway to the return side of DC power source one, as shown in figure 2.9 on page 24.
2. Connect another wire from the negative terminal of the 3200 series gateway to the -48V side of DC power source one.
3. Connect a ground wire from the ground terminal of the 3200 series gateway to earth ground.
4. Repeat steps 1-3 for the second power DC power source.

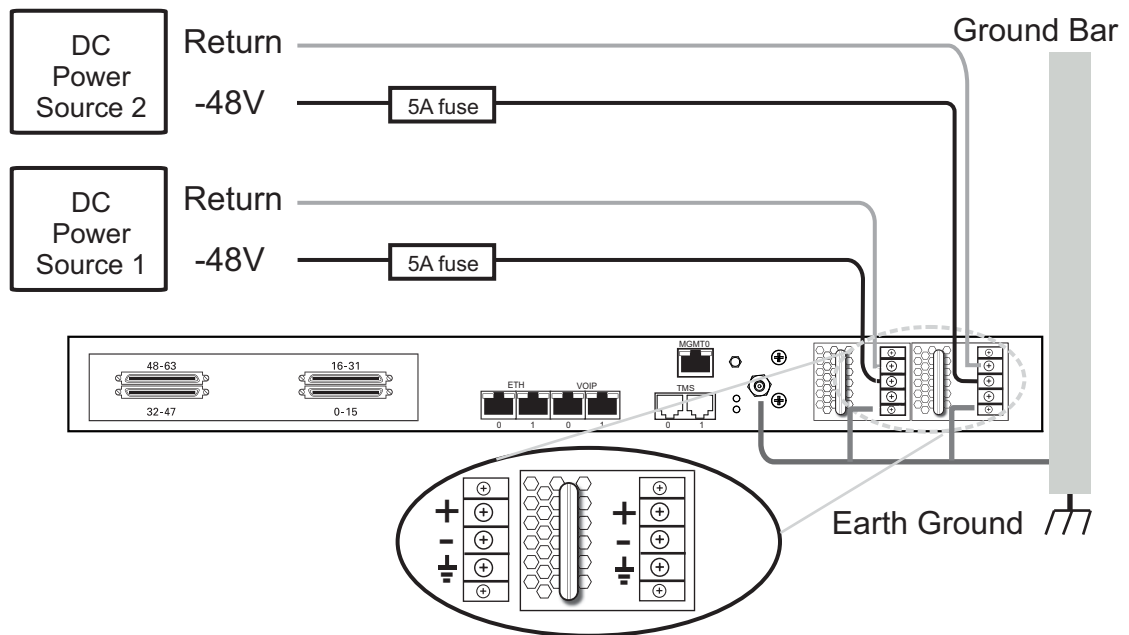

Figure 2.9 3200 Series Gateway DC Wiring Diagram

2.4.6 Start Up



The first time that you connect to a 3200 series gateway, the web portal will appear and you will be asked to select how you would like to configure the 3200 series gateway. You will want to be sure to set the role as a 3200 series standalone.

Once the configuration settings have been applied, the 3200 series gateway will start up and display the web portal configuration management tool.

Note To learn about the IP address for your system or how to change it, refer to Section 3.5 “Changing the 3200 Series Gateway Management Port IP Address” on page 55.

2.4.6.1 Configuring the Role

To configure the role of the 3200 series gateway as a standalone unit, do the following:

1. Connect to the web portal of the standalone unit. The Welcome page appears.

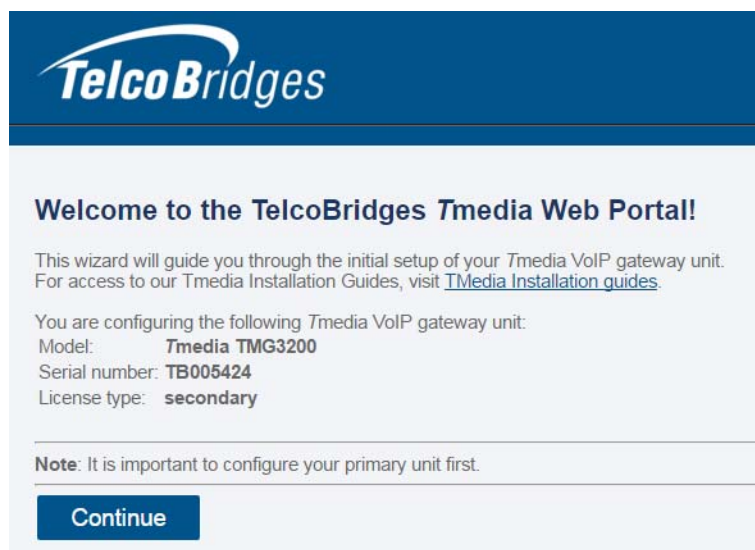

2. Follow the instructions of the web portal to set the role of the unit to a standalone gateway.



2.5

3200 Series 1+1 System

If you are here, you are installing a 3200 series 1+1 system. This section covers the following procedures:

- Section 2.5.1 “Connecting to the 3200 Series 1+1 System Management Interfaces” on page 27.
- Section 2.5.2 “Connecting to the Control Network” on page 28.
- Section 2.5.3 “Connecting the 3200 Series 1+1 System VoIP Network(s)” on page 29.
- Section 2.5.4 “Connecting to the PSTN in a 3200 Series 1+1 System” on page 30.
- Section 2.5.5 “Grounding the Equipment Chassis” on page 36.
- Section 2.5.6 “Powering Up” on page 37.
- Section 2.5.7 “Start Up” on page 39.



2.5.1 Connecting to the 3200 Series 1+1 System Management Interfaces

The management interface enables administrators to perform management tasks on a 3200 series 1+1 system.

Prerequisites

To communicate with the management interface, the following is needed:

- Two CAT5 Ethernet cables with RJ45 male-male terminations.

Interconnections

A 3200 series 1+1 system provides a management interface for a 3200 series and a 3200 +1 gateway, each require a Gigabit Ethernet network link. See figure 2.10 on page 27.

To communicate with the management interface:

1. Connect an RJ45 cable from the 3200 series gateway to a gigabit Ethernet switch.
2. Connect an RJ45 cable from the 3200 series +1 gateway to a gigabit Ethernet switch.

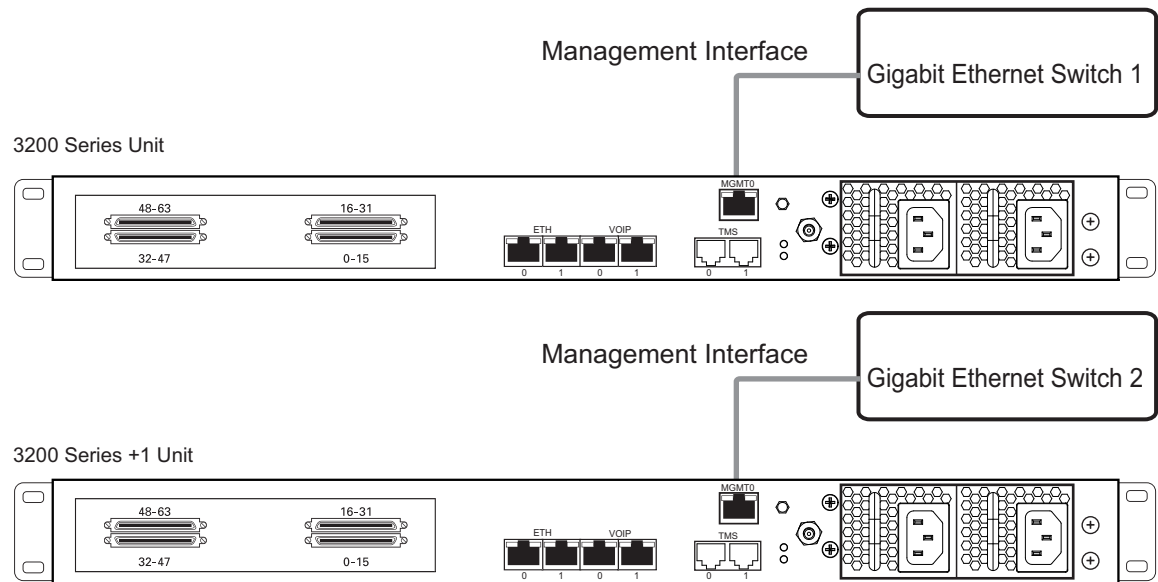

Figure 2.10 3200 Series 1+1 System Management Interface



2.5.2

Connecting to the Control Network

The 3200 series control network enables a 3200 series unit to be connected to a 3200 series +1 unit, allowing for a sharing of system resources.

Prerequisites

To connect to the control network, you will need:

- Two CAT5 Ethernet cables with RJ45 male-male terminations.

Connections

The 3200 series unit and 3200 series +1 are connected to the control network using two CAT5 Ethernet cables, as shown in figure 2.11 on page 28.

To connect to the control network:

1. Connect the ETH0 connector on the 3200 series unit to the ETH0 connector on the 3200 series +1 unit.
2. Connect the ETH1 connector on the 3200 series unit to the ETH1 connector on the 3200 series +1 unit.

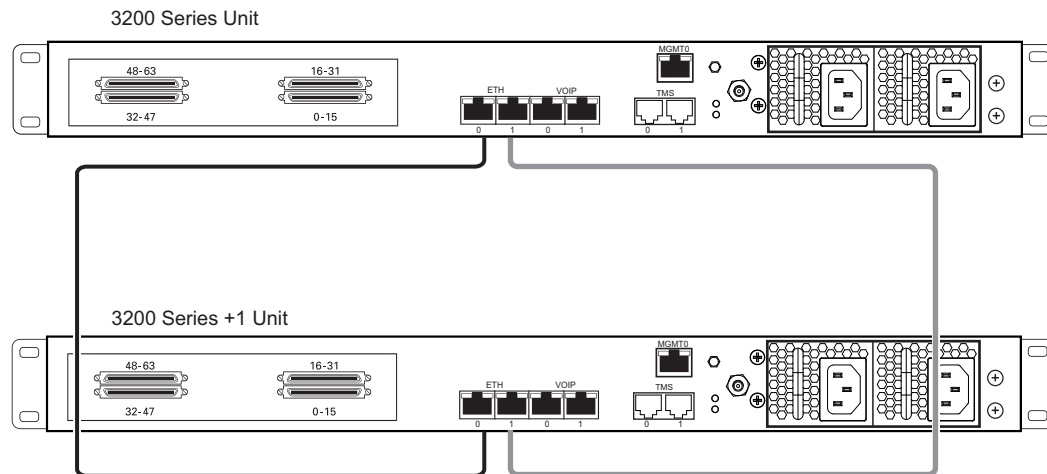

Figure 2.11

Connecting to the Control Network



2.5.3 Connecting the 3200 Series 1+1 System VoIP Network(s)

Each 3200 series unit and 3200 series +1 unit features dual GigE ports for connection to different VoIP networks. This provides an access point to manage VoIP traffic. Should one of the IP networks fail, the 3200 series 1+1 system will continue to manage VoIP traffic using the alternate network.

The IP address of the VoIP ports can be modified using the web portal.

Note: The 3200 series 1+1 system requires two (2) gigabit layer 2 Ethernet switches.

Prerequisites

To connect the 3200 series unit and 3200 series +1 unit to the VoIP network, you will need:

- Two gigabit layer 2 Ethernet switches. A second one is required to support redundancy of the VoIP interface.
- Four CAT5 Ethernet cables with RJ45 male-male terminations.
- Two IP addresses located on different subnets.

Connections

The 3200 series unit and 3200 series +1 unit are connected to the VoIP network by one or optionally two Ethernet GigE network links, as shown in figure 2.12 on page 29.

To connect to the VoIP network:

1. Connect the VoIP0 connector from both the 3200 series unit and 3200 series +1 unit to the first Ethernet switch.
2. Connect the VoIP1 connector from both the 3200 series unit and 3200 series +1 unit to the second Ethernet switch.

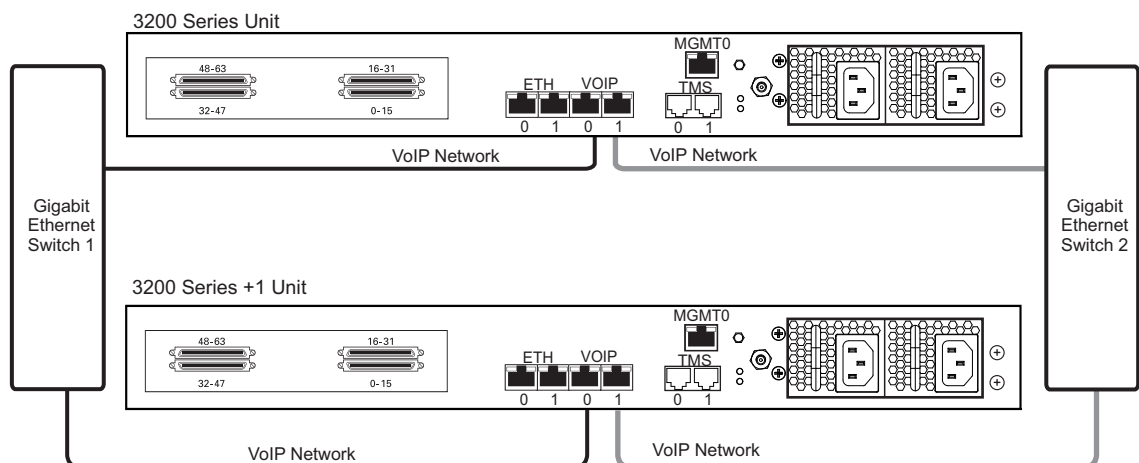

Figure 2.12 Connecting to the VoIP Network

2.5.4 Connecting to the PSTN in a 3200 Series 1+1 System



Note This section only applies to the TMG3200 and TSG3200 systems.

The 3200 Series 1+1 system features a variety of interfaces to the PSTN network.

Prerequisites

To connect to the PSTN network, you must comply with one of the following:

- Your 3200-TE and 3200-TE+1 feature SCSI connectors that in turn connect to an SCSI patch panel to terminate in RJ48C connectors for connection to T1/E1 lines.
- . You will require one 1+1 patch panel for each 32 line grouping of T1/E1 line interfaces on a 3200 series 1+1 system.
- Your 3200-DS3 and 3200-DS3+1 feature BNC connectors for connection to DS3 lines. You will require two coaxial cables for each DS3 interface.
- Your 3200-STM1 and 3200-STM1+1 feature electrical or optical STM-1 connectors. You will require two fiber optic cables for each STM-1 interface.

2.5.4.1 SCSI Interface (T1/E1) for the 3200-TE and 3200-TE+1

A 3200-TE and 3200-TE+1 with SCSI patch panels enables the connection to T1/E1 lines. The termination impedance is set at 120 ohms. It is possible to connect an external balun in order to convert to 75 ohms.



Note All ports may not be active. T1/E1 ports are activated by software license; the number of active ports depends on the licenses purchased.

Patch panels use straight connections. In other words, they do not cross the RX and TX signals. Connections between patch panels and 3200 series 1+1 systems requires straight cables. (The supplied SCSI cables are straight cables.) Cables that are used to connect the network to the 1+1 patch panel must make the cross connection.

To connect both the 3200-TE and 3200-TE+1 (SCSI) to the PSTN:

1. Connect each T1/E1 line from the network section of the 1+1 patch panel to the remote equipment. See figure 2.13 on page 32.
2. Connect SCSI ports 0-15 from the Gateway section at the rear of the 1+1 patch panel to the SCSI ports 0-15 of the 3200-TE.
3. Connect SCSI ports 16-31 from the Gateway section at the rear of the 1+1 patch panel to the SCSI ports 16-31 of the 3200-TE.
4. Connect SCSI ports 0-15 from the Gateway 1+1 section at the rear of the 1+1 patch panel to the SCSI ports 0-15 of the 3200-TE+1.
5. Connect SCSI ports 16-31 from the Gateway 1+1 section at the rear of the 1+1 patch panel to the SCSI ports 16-31 of the 3200-TE+1.

Note: To connect 32 more lines to the 3200-TE and the 3200-TE+1, install another 1+1 patch panel and connect the additional 32 lines to ports 32-63 on each unit.

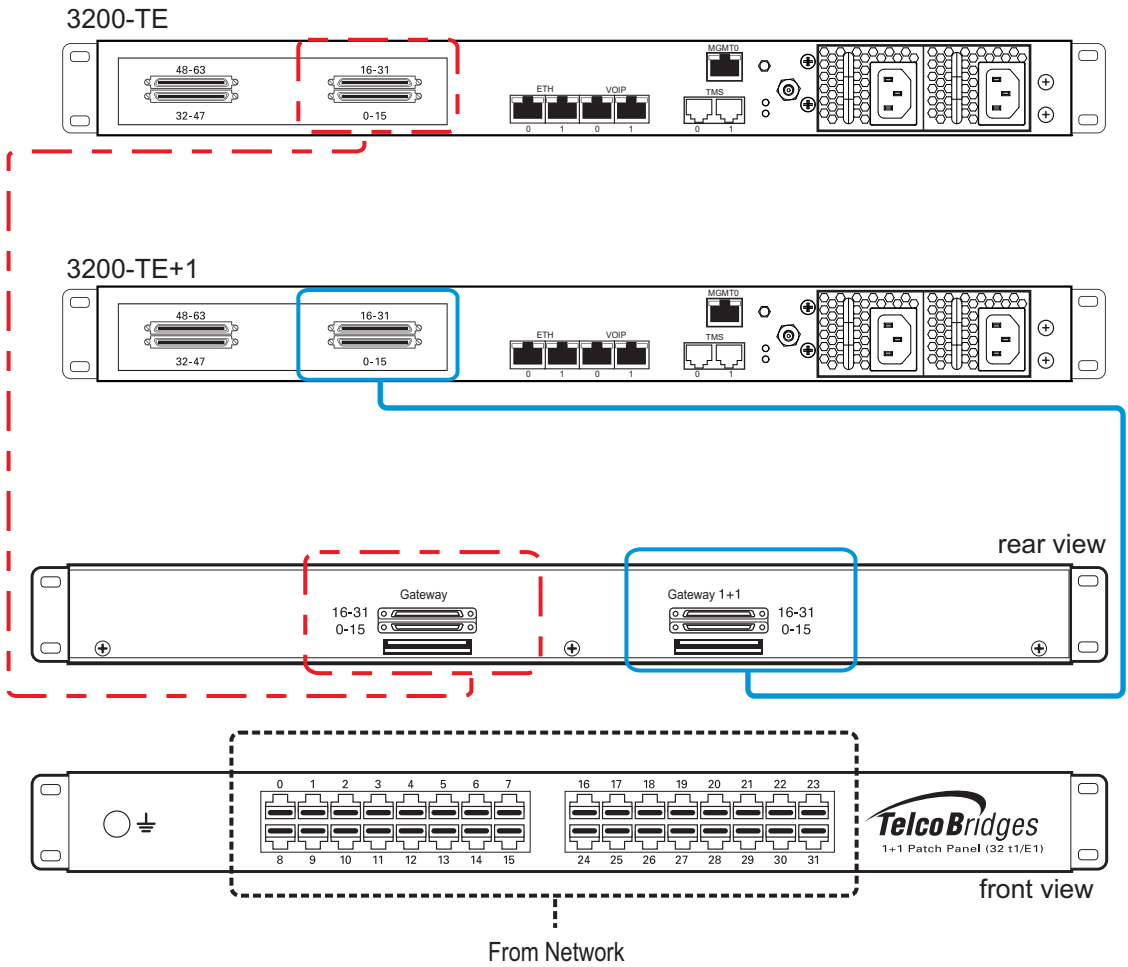

Figure 2.13 3200-TE and 3200-TE+1 connecting to the TDM 1+1 32/T1/E1 1+1 patch panel

2.5.4.2 Dual BNC Interface (DS3) for the 3200-DS3 and 3200-DS3+1

A 3200-DS3 and 3200-DS3+1, each with 3 sets of BNC connectors, enables the connection to DS3 lines. See figure 2.14 on page 33.



Note All ports may not be active. DS3 ports are activated by software license; the number of active ports depends on the licenses purchased.

Patch panels use straight connections. In other words, they do not cross the RX and TX signals. You must connect RX to RX, and TX to TX between the 1+1 patch panels and 3200 Series 1+1 system. Cables used to connect the network to the 1+1 patch panel must do the cross connection.

To connect both the 3200-DS3 and 3200-DS3+1 to the PSTN:

1. Connect each DS3 line from the network section of the 1+1 patch panel to the remote equipment. See figure 2.14 on page 33.
2. Connect each DS3 line from the DS3 connectors labeled **Gateway** of the 1+1 patch panel to the 3200-DS3.
3. Connect each DS3 line from the DS3 connectors labeled **1+1** of the 1+1 patch panel to the 3200-DS3+1.

Optional

1. Connect bits port 0 and 1 from the 3200-DS3 to the 1+1 patch panel
2. Connect bits port 0 and 1 from the 3200-DS3+1 to the 1+1 patch panel

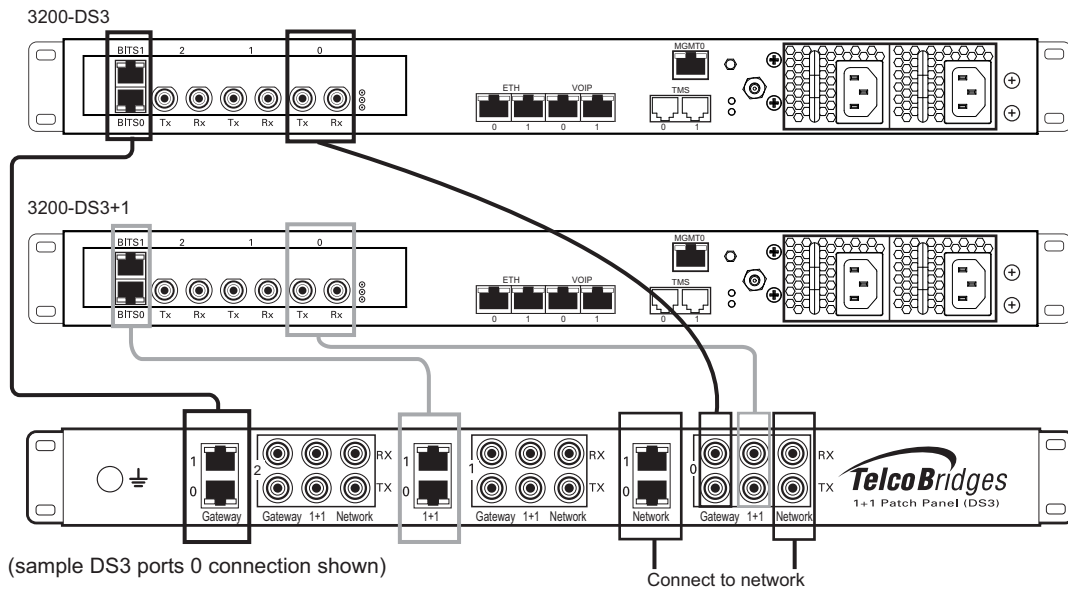

Figure 2.14 3200-DS3 and 3200-DS3+1 connecting to the TDM 1+1 DS3 1+1 patch panel

2.5.4.3 Optical Interface (OC3/STM-1)



A 3200-STM1 and 3200-STM+1, each with one main and one backup OC3 or STM1 port enables the connection to OC3/STM1 lines. See figure 2.15 on page 35. Refer to table 2.4 on page 34 for a listing of optical interfaces. The default SFP module for OC3/STM1 connection is SMF, intermediate reach, (SFP-OC3-IR1) 1310 nm with LC type connectors.

Note Make certain that the correct SFP model is selected at the time of ordering. If your installation requires a different model from the one that has been provided, you must replace it.

Table 2.4 Optical Interfaces

Transceiver Model	Description	Spec	Mode	Type	Range (Km.)	Wavelength (NM)	Connection
SFP-OC3-IR1	OC3/STM1	Hot Pluggable	Single-mode	Intermediate reach	15	1310	LC
SFP-STM1E	STM1E (Electrical)	Hot Pluggable	75 ohms Cooper	Max 180m	1	NA	DIN (mini-coax)

Automatic Protection Switching

The APS port is used for OC3/STM1 redundancy. Switchover occurs automatically based on configurable parameters. It is recommended that APS be used if the installation provides this feature.

Note Patch panels use straight connections. In other words, they do not cross the RX and TX signals. You must connect RX to RX, and TX to TX between the 1+1 patch panels and 3200 series 1+1 system. Cables used to connect the network to the 1+1 patch panel must do the cross connection.

To connect both the 3200-STM1 and 3200-STM +1 (Optical Interface) to the PSTN:

1. Connect each OC3/STM1 line of the network section of the 1+1 patch panel to the remote equipment. See figure 2.15 on page 35.
2. Connect a fiber optic cable between STM1 of the Gateway section of the 1+1 patch panel and the main port of the 3200-STM1.
3. Connect a fiber optic cable between APS of the Gateway section of the 1+1 patch panel and the APS port of the 3200-STM1.
4. Connect a fiber optic cable between STM1 of the Gateway 1+1 section of the 1+1 patch panel and the main port of the 3200-STM1 +1.
5. Connect a fiber optic cable between APS of the Gateway 1+1 section of the 1+1 patch panel and the APS port of the 3200-STM1 +1.

Optional

1. Connect bits port 0 and 1 from the 3200-STM1 to the 1+1 patch panel
2. Connect bits port 0 and 1 from the 3200-STM1+1 to the 1+1 patch panel

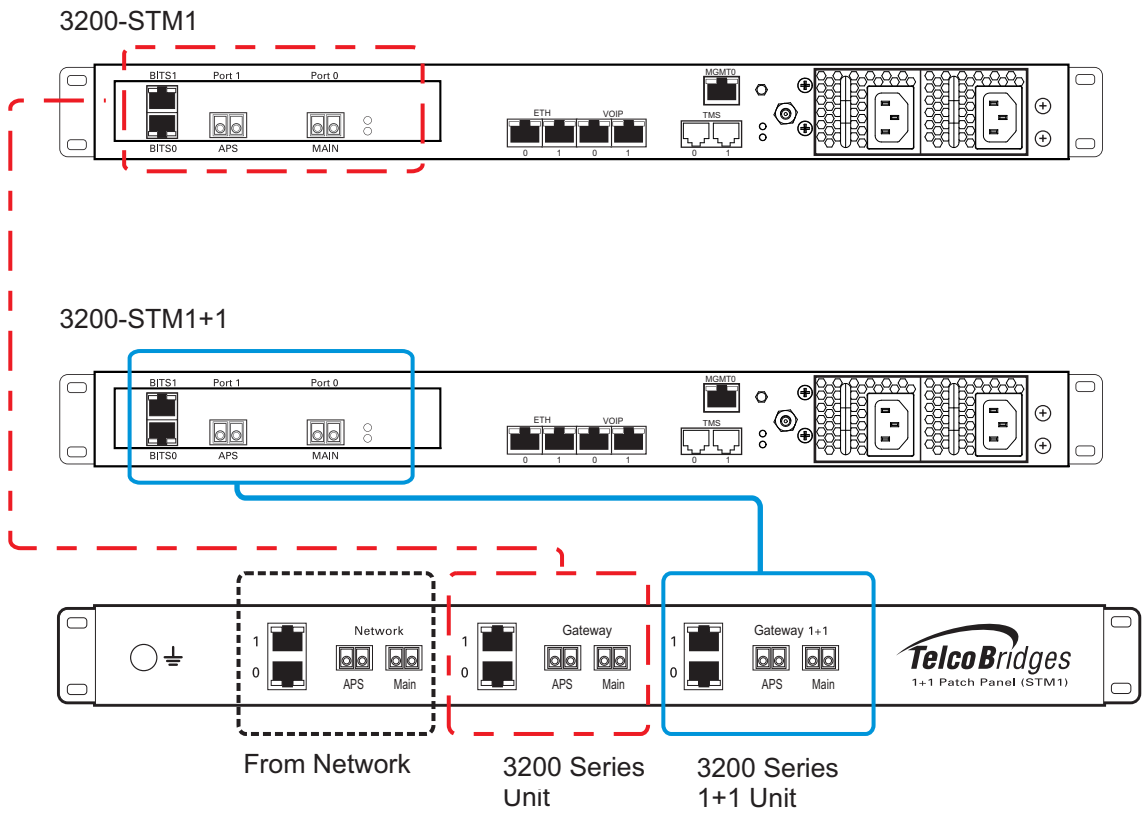

Figure 2.15 3200-STM1 and 3200-STM1 +1 connecting to the STM1 1+1 patch panel

2.5.5 Grounding the Equipment Chassis



As a standard safety practice, the chassis of the 3200 series gateway must be properly grounded to protect against any contact with an electrical fault condition. It is recommended that the chassis be connected to an earth ground. When the 3200 series gateway is installed in an equipment rack, connect the ground wire between the ground lug of the gateway and the equipment rack ground bar. If more than one 3200 series gateway is installed in an equipment rack, each 3200 series gateway must be grounded directly to the equipment rack ground bar.

Guidelines

- Use 10 AWG (minimum) stranded ground wire.
- Terminate equipment side of ground wire with a #10 ring terminal.
- Keep the length of the ground wire as short as possible.
- Do NOT daisy chain the ground between equipment. Use a ground bus bar.
- Do not over tighten ground lug connections.

To connect to the 3200 series gateway to ground:

1. Connect one end of a ground wire to the ground lug of the 3200 series gateway. See figure 2.16 on page 36.
2. Connect the other end of the ground wire to a ground bar of the equipment rack. If the 3200 series gateway is not installed in an equipment rack, connect the ground wire to earth ground.
3. Verify that the resistance of the ground path is less than 0.5 ohms.

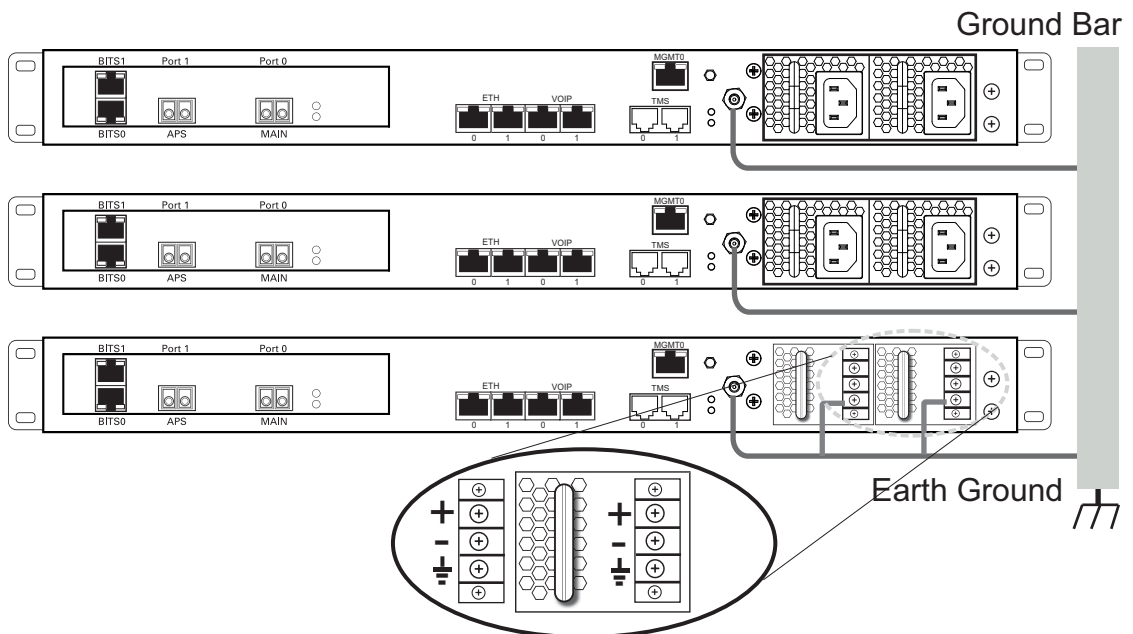

Figure 2.16 Chassis Ground Connection

2.5.6 Powering Up

The 3200 series unit and 3200 series +1 unit are furnished with two (2) AC or two (2) DC power connections. Only once all other equipment installation work has been completed should the 3200 series 1+1 system be powered up.



Prerequisites

To connect power you will need:

- Two independent AC power sources.
- Two power cables for each 3200 series unit and 3200 series +1 unit.

2.5.6.1 Connecting to AC Power

The 3200 series and 3200 series +1 AC models are furnished with two AC power connectors.

To connect to AC Power:

1. Connect the first power connector of each unit to the first power source. See Figure 2.17.
2. Connect the second power connector of each unit to the second power source.

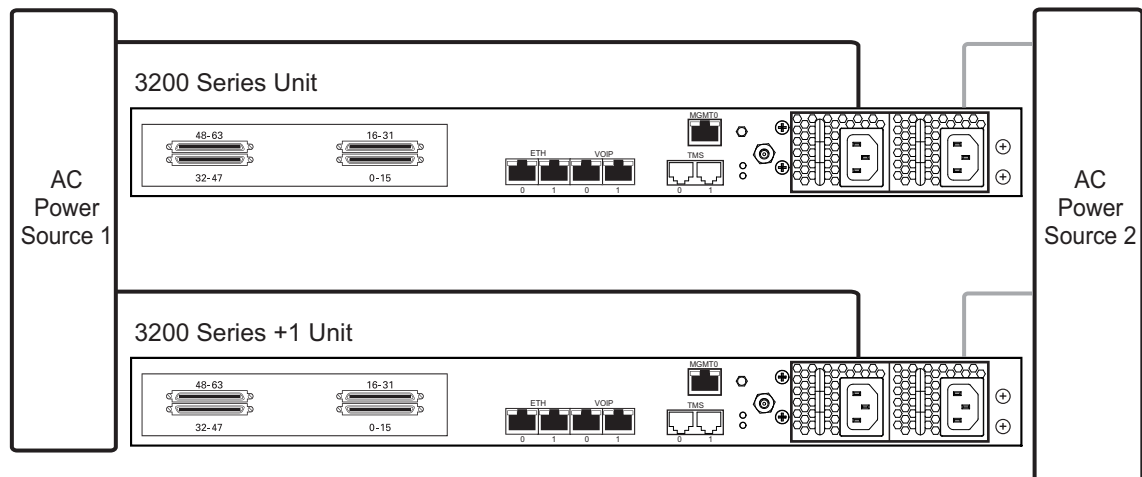

Figure 2.17 3200 Series and 3200 Series +1 AC Power Connections

2.5.6.2 Connecting to DC Power

The 3200 series and 3200 series +1 DC models are furnished with two DC power connection ports. In addition, each DC powered device is supplied with two DC power cables.



Fuse and Cabling Requirements

16 AWG wiring must be used and the 48V supply must be protected with a customer provided 5A 48V fuse.

To connect the 3200 series and 3200 series +1 unit to DC Power

1. Connect one wire from the positive terminal of the 3200 series gateway to the return side of DC power source one, as shown in figure 2.18 on page 38.
2. Connect another wire from the negative terminal of the 3200 series gateway to the -48V side of DC power source one.
3. Connect a ground wire from the ground terminal of the 3200 series gateway to earth ground.
4. Repeat steps 1-3 for the second power DC power source.

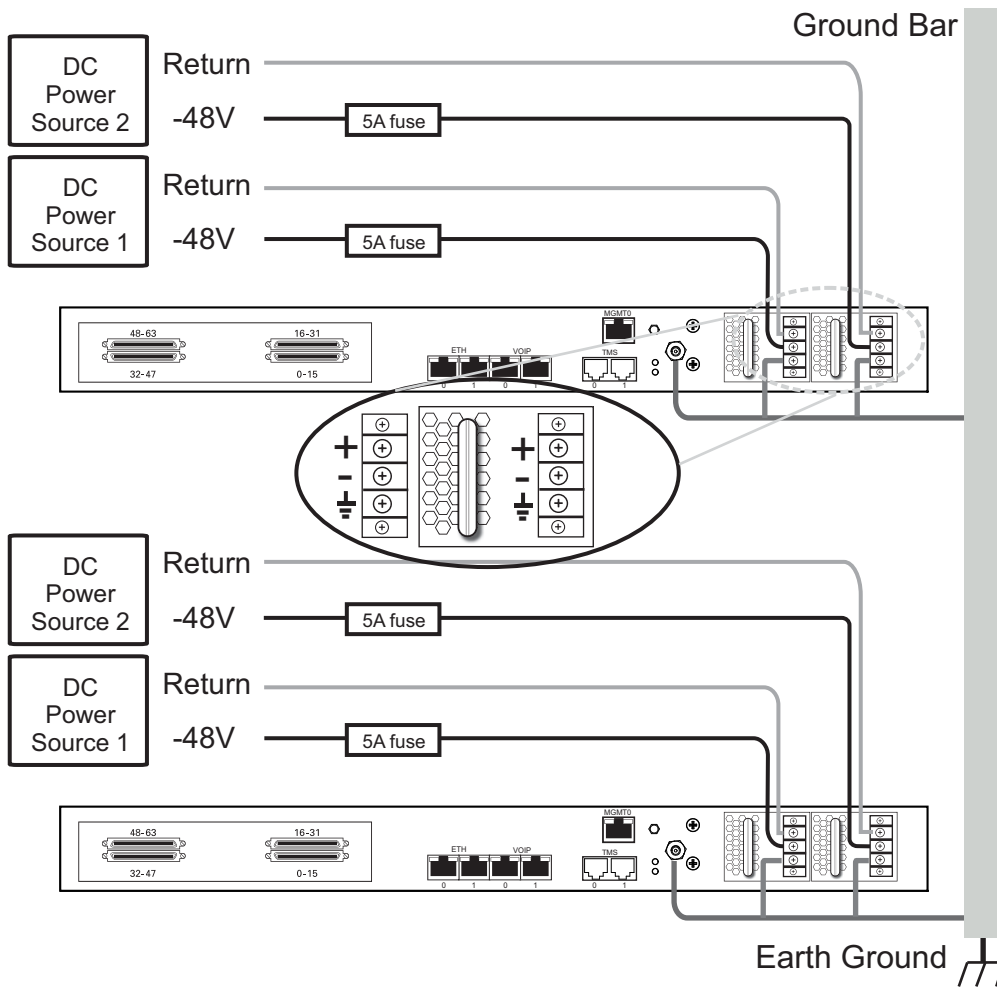

Figure 2.18 3200 Series and 3200 Series +1 DC Power Connections

2.5.7 Start Up

After powering up the 3200 series 1+1 system, you must configure both units, one as primary and the other as secondary.

Once these configuration settings are applied, your 3200 series 1+1 system will start up and display the web portal configuration management tool.



Note To learn about the IP address for your system or how to change it, refer to Section 3.5 “Changing the 3200 Series Gateway Management Port IP Address” on page 55.

1. Connect to the web portal ([http://\[MGMT0 IP address\]:12358](http://[MGMT0 IP address]:12358)) and select the role of the unit to be part of a 1+1 redundant system.

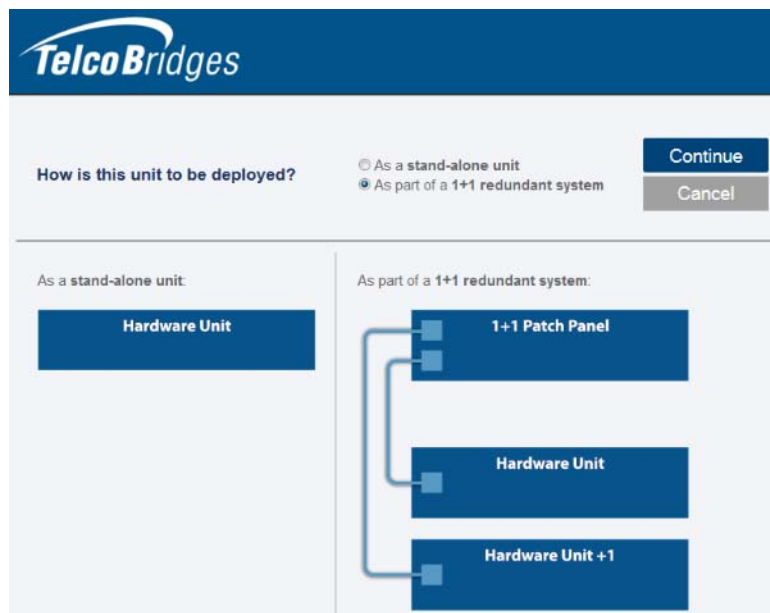

Note: The Welcome page indicates whether the 3200 series unit is primary or secondary.

2. Follow the instructions of the web portal to configure the units of your 3200 series 1+1 system. Indicate the following:
 - Select Primary for the 3200 Series and Secondary for the 3200 Series+1.
 - VLAN IDs: By default the system will be using VLAN IDs 710 and 711 between the two units. You may need to change this if it conflicts with your network.

3. Once you confirm the changes, a progress page is displayed.

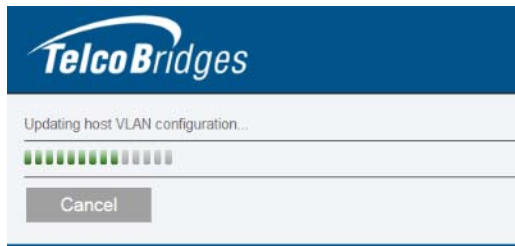

2.6 Add a 3200 Series +1 Unit to a Standalone, Creating a 3200 Series 1+1 System

Warning: This procedure will require some system downtime.



In order to add a 3200 series +1 unit to a 3200 series standalone unit, you must perform the following procedures:

- Section 2.6.1 “Reconfigure a Standalone Unit as a Primary Unit in an 3200 Series 1+1 System”
- Section 2.6.2 “Install the 3200 Series +1 Unit on the Equipment Rack”
- Section 2.6.3 “Install a 1+1 Patch Panel”
- Section 2.6.4 “Connect to the 3200 Series 1+1 Management Interface”
- Section 2.6.5 “Connect to the 3200 Series 1+1 Control Network”
- Section 2.6.6 “Connect to the VoIP Network”
- Section 2.6.7 “Connect to the PSTN Network”
- Section 2.6.9 “Power Up the 3200 Series 1+1 System”
- Section 2.6.10 “Start Up”

2.6.1 Reconfigure a Standalone Unit as a Primary Unit in an 3200 Series 1+1 System

1. Connect to the web portal of the standalone 3200 series unit.
2. Select **Hosts** from the navigation panel.

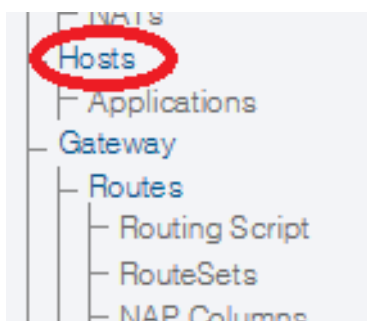

3. Select a host from the **Host Configuration List**.



Configuration Status

[Create New Host](#)

Host Configuration List

Name	Applications
TB005577	gateway, logtrace, stream_server, tboamapp, tbsnmpagent, tbuctwriter, toolback_engine, t...

4. Select the **Status** tab.

Configuration Status

List

Editing Host Configuration:

Name

Applications

Current		<<	Available
Applications	Action		
stream_server	Remove		
toolback_engine			
toolback_sys_mgr			
tbuctwriter	Remove		
gateway	Remove		
logtrace			
tboamapp			
tbsnmpagent	Remove		

Editing Folder Cleanup:

[Create all default folder cleanup configurations](#)

[Create New Folder Cleanup](#)

Name	Folder Path	Mask	Max files	Max size	Max age	Actions
------	-------------	------	-----------	----------	---------	---------

5. Select Reset Host Role.

The screenshot shows the 'Host Status' page for unit TB005424. The 'Host Control' dropdown menu is open, showing the following options: None, Shutdown, Validate Requirements, Upgrade Linux Packages, and Reset Host Role. The 'Reset Host Role' option is highlighted in blue.

Name	Value
Host	TB005424
Host role	Secondary
Oram mode	Slave
Oram state	Ready
Trng host	Yes
Host platform	TMG3200 Centos
Host package	x86_64-linux64_centos5
Host control last upload action	None

6. Follow the instructions of the web portal to configure your unit as a primary unit in a new 3200 series 1+1 system.

2.6.2 Install the 3200 Series +1 Unit on the Equipment Rack

The 3200 series +1 unit is mounted on a customer provided equipment rack using the mounting hardware packaged in the box. Refer to Section 2.2 “Rack Mounting the 3200 Series Standalone or 3200 Series 1+1 System” on page 11.



2.6.3 Install a 1+1 Patch Panel

Note This section only applies to the TMG3200 and TSG3200.

<p>If your system features a 3200-TE TDM interface, use a 1+1 patch panel (32/T1/E1). Refer to Section 2.5.4.1 “SCSI Interface (T1/E1) for the 3200-TE and 3200-TE+1” on page 31.</p> <p>Note: Patch panels must be replaced by the 3200-TE-1+1 patch panels.</p>	
<p>If your system features a 3200-DS3 TDM interface, use a 1+1 patch panel (DS3). Refer to Section 2.5.4.2 “Dual BNC Interface (DS3) for the 3200-DS3 and 3200-DS3+1” on page 33.</p>	
<p>If your system features a 3200-STM1 TDM interface, use a 1+1 patch panel (STM1). Refer to Section 2.5.4.3 “Optical Interface (OC3/STM-1)” on page 34.</p>	

2.6.4 Connect to the 3200 Series 1+1 Management Interface

The Management interface enables administrators to perform management tasks on a 3200 series 1+1 system.

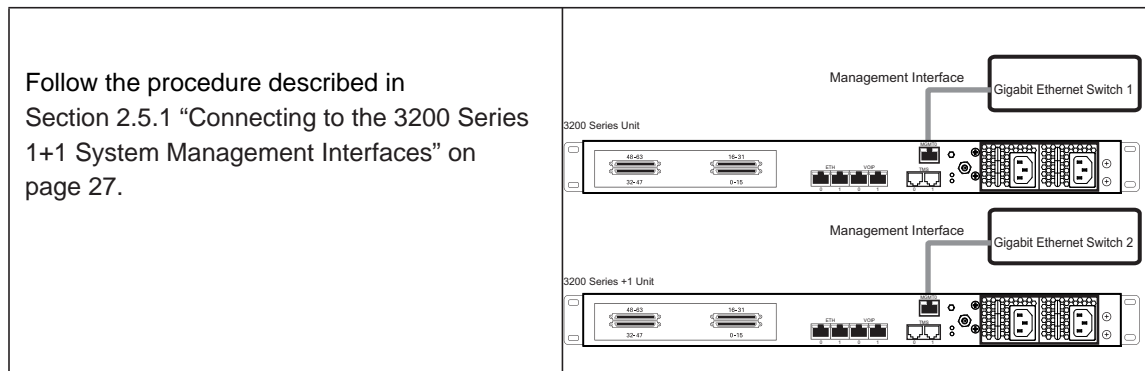

2.6.5 Connect to the 3200 Series 1+1 Control Network

The control network permits a 3200 series unit to connect to a 3200 series +1 unit, thereby enabling a sharing of system resources.

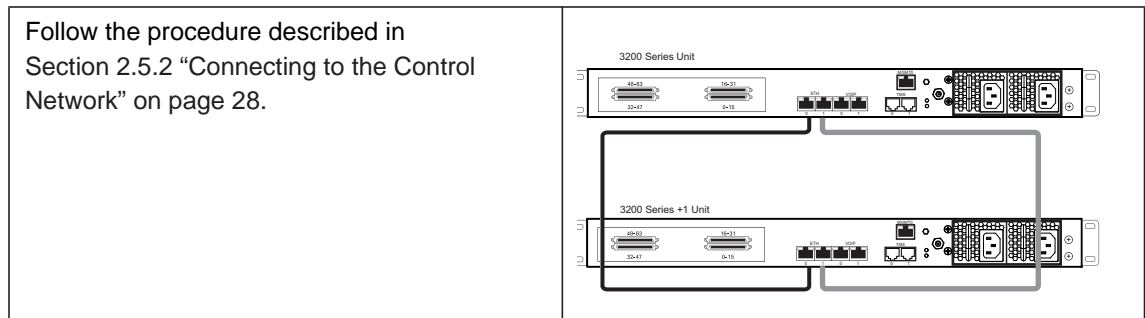

2.6.6 Connect to the VoIP Network

The 3200 series 1+1 system features dual GigE ports for connection to different VoIP networks. This provides an access point to manage VoIP traffic. Should one of the IP networks fail, the 3200 series 1+1 system will continue to manage VoIP traffic using the alternate network.

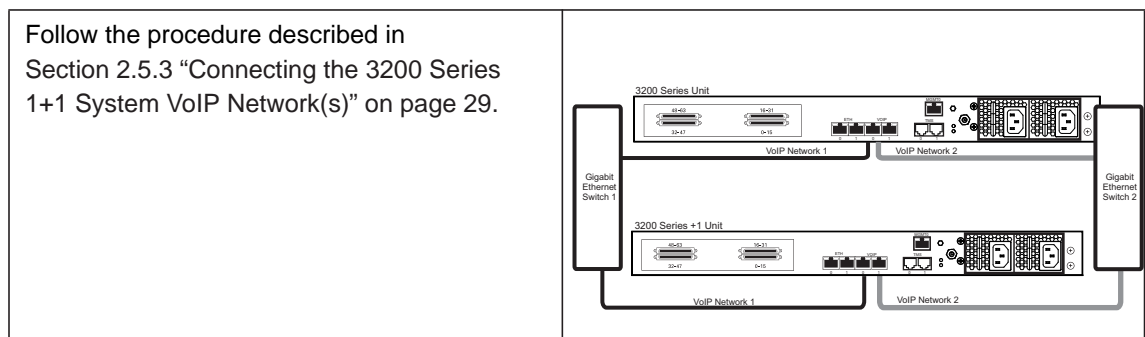

2.6.7 Connect to the PSTN Network



Note This section only applies to the TMG3200 and TSG 3200.

3200 series gateways feature a variety of interfaces to the PSTN network.

<p>If your system features a 3200-TE TDM interface, refer to Section 2.5.4.1 “SCSI Interface (T1/E1) for the 3200-TE and 3200-TE+1” on page 31.</p> <p>Patch panels must be replaced by the 1+1 patch panel.</p>	
<p>If your system features a 3200-DS3 TDM interface, refer to Section 2.5.4.2 “Dual BNC Interface (DS3) for the 3200-DS3 and 3200-DS3+1” on page 33.</p>	
<p>If your system features a 3200-STM1 TDM interface, refer to Section 2.5.4.3 “Optical Interface (OC3/STM-1)” on page 34.</p>	

2.6.8 Grounding the Equipment Chassis

As a standard safety practice, the chassis of the 3200 series gateway must be properly grounded to protect against any contact with an electrical fault condition. It is recommended that the chassis be connected to an earth ground. When the 3200 series gateway is installed in an equipment rack, connect the ground wire between the ground lug of the gateway and the equipment rack ground bar. If more than one 3200 series gateway is installed in an equipment rack, each 3200 series gateway must be grounded directly to the equipment rack ground bar



2.6.9 Power Up the 3200 Series 1+1 System

The 3200 series and 3200 series +1 units are furnished with either two AC or DC power connections. Only once all other equipment installation work has been completed should the 3200 series 1+1 system be powered up.

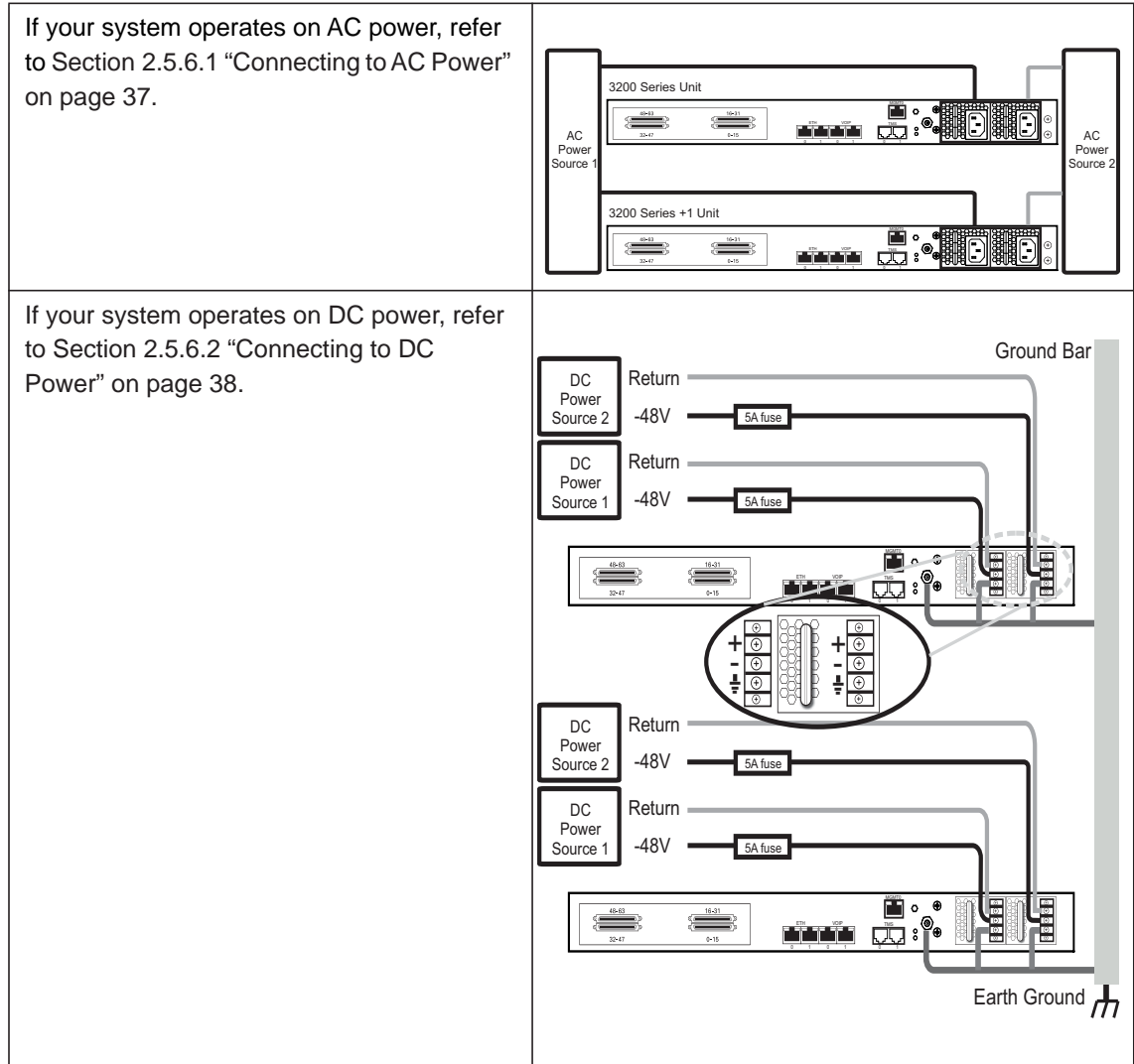

2.6.10 Start Up



Note To learn about the IP address for your system or how to change it, refer to Section 3.5 “Changing the 3200 Series Gateway Management Port IP Address” on page 55.

1. Connect to the web portal of the 3200 series 1+1 system. The Welcome page appears.



2. Follow the web portal instructions to configure your unit as a secondary unit in a new 3200 series 1+1 system.

2.7 Verifying the LED Status Indications

Front of Unit

When the equipment is powered, verify the front panel to determine that the LED indication is normal. See Table 2.5 on page 49.



Table 2.5 320000 Series Unit Displays

LED	Description
Green - Steady	<ul style="list-style-type: none"> • Ready
Green - Blinking	<ul style="list-style-type: none"> • Starting up • Shutting down
Orange - Steady	<ul style="list-style-type: none"> • Shut down (stopped)
Red - Blinking	<ul style="list-style-type: none"> • Fault condition

Note An alarm will sound if one of the power supplies is faulty. There is no alarm button to disable the alarm. To stop the alarm, you must remove the faulty power supply.

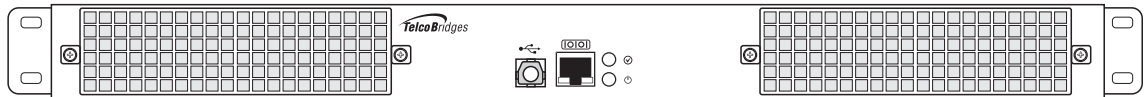

Figure 2.19

2.8 Powering Down



Attention DO NOT TURN OFF the power to the 3200 series gateway using the power switch located at the rear, unless the Linux host has been properly shut down beforehand. Use the reset button display, or manually use the shutdown command.

Allow enough time for the Linux host to shut down before turning off the power to the 3200 series system (example. 1 minute). Be aware that the shutdown procedure of the unit is logged and traceable for support and warranty purposes.

2.8.1 Local Method

To power down the 3200 series, press and hold the reset button for two seconds.

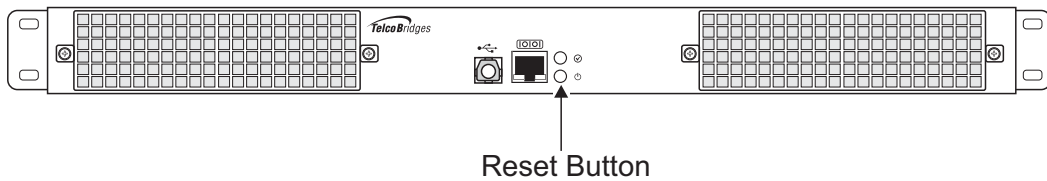

2.8.2 Remote Method

To power down, you must connect to the management interface using SSH, and enter:

```
shutdown -hP now
```



Section 3 Initial System Configuration

This chapter provides information about the following topics:

- Section 3.1 “3200 Series Gateway SSH Connection”
- Section 3.2 “3200 Series Gateway Serial Connection”
- Section 3.3 “Changing 3200 Series Gateway Management Port Passwords”
- Section 3.4 “Retrieving 3200 Series Gateway Information”
- Section 3.5 “Changing the 3200 Series Gateway Management Port IP Address”
- Section 3.3 “Changing 3200 Series Gateway Management Port Passwords”
- Section 3.6 “Setting the Time Zone”
- Section 3.7 “Configuring the 3200 Series Gateway Using the Web Portal”
- Section 3.8 “Changing VoIP Interface Addresses”



3.1 3200 Series Gateway SSH Connection

The 3200 Series Gateway is shipped with the TMG-CTRL software preinstalled. In order to make changes to the system configuration, you must connect the port labeled MGMT0 at the rear of the 3200 Series Gateway to a terminal.

To access the 3200 Series Gateway, you must use an SSH connection. The **password** is set at the factory and is indicated on the shipment sheet.

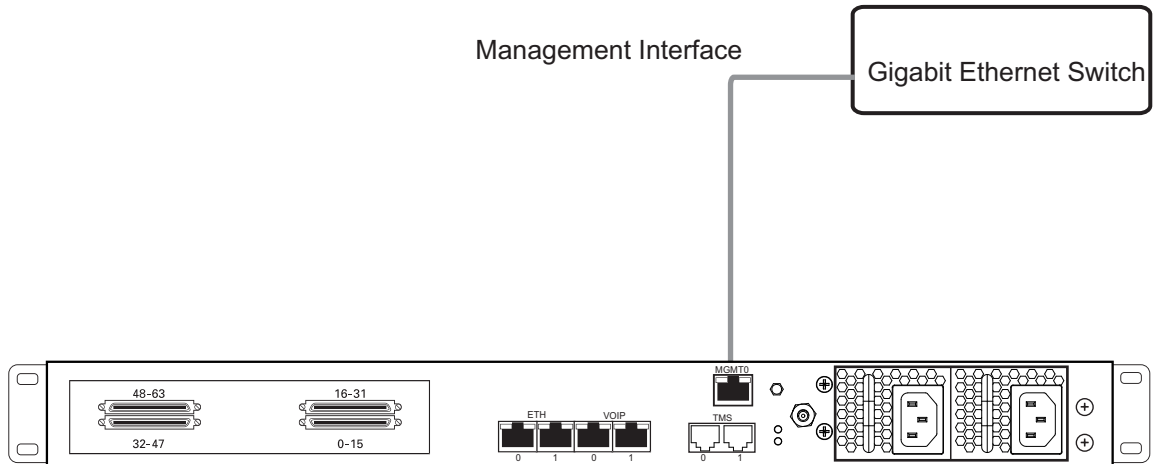

Figure 3.1 3200 Series Gateway Management Interface

Note See Section 3.5 on page 55 to learn how to change the IP address of the MGMT0 port.

3.2 3200 Series Gateway Serial Connection

3.2.1 Physical Connection

Two types of serial connection are possible:

- Section 3.2.1.1 “Connecting to the USB Port of the 3200 Series Gateway”
- Section 3.2.1.2 “Connecting to the Serial Port of the 3200 Series Gateway”

3.2.1.1 Connecting to the USB Port of the 3200 Series Gateway

The Type B USB serial port interface enables administrators to perform management tasks on the 3200 series gateway.



Note The USB cable is not provided.

To connect to the Type B USB serial port of an 3200 series gateway:

1. Connect the Type A USB connector of the USB cable to a computer.
2. Connect the Type B USB connector of the USB cable to the USB port of the 3200 Series gateway.

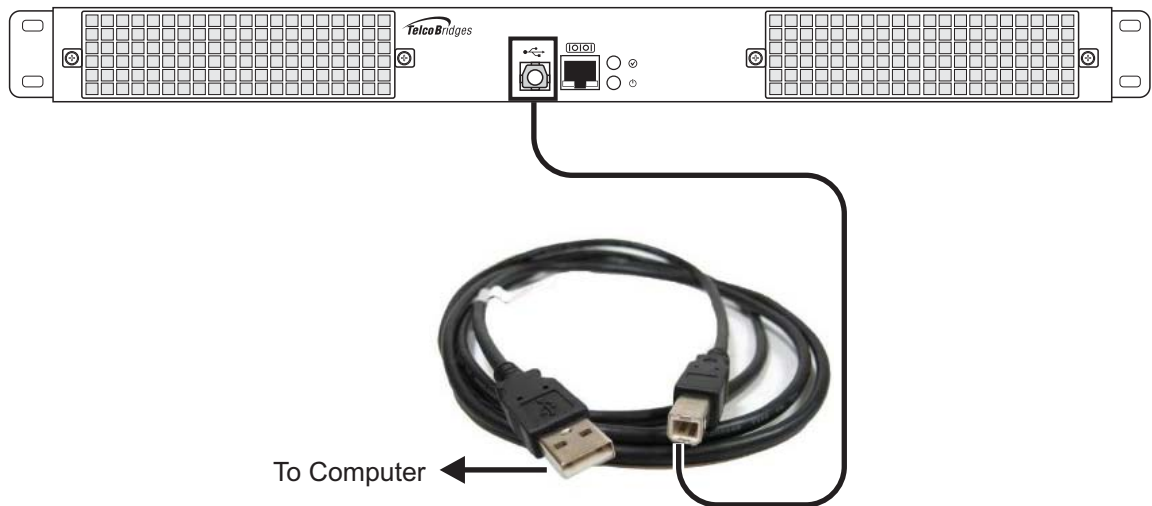

Figure 3.2 USB cable connection

3.2.1.2 Connecting to the Serial Port of the 3200 Series Gateway

Note The default IP addresses for the management ports are located in the “Important Notice” sheet received with the shipment.

If you do not know the default IP address, go to Section 3.5 “Changing the 3200 Series Gateway Management Port IP Address” on page 55.

The serial port interface enables administrators to perform management tasks on the 3200 series gateway.

To connect to the serial port of a 3200 series gateway:

1. Connect one end of a CAT5 RJ-45 (male-male) cable to the Tmedia serial adapter (both supplied with unit). Connect the DB9 to RJ-45 to the serial port of the computer and the other end of the CAT5 RJ-45 (male-male) cable to the serial port (labeled 10101) of the 3200 series gateway. See Section A.2 on page 61 for a RJ-45 pin-out description.



2. If your computer's serial port features a DB9 connector connect directly otherwise use the Tmedia serial adapter supplied with your 3200 series gateway. If your computer's serial port features a USB connector, you will need to provide a USB to DB9 adapter. Refer to figure 3.3 on page 54.

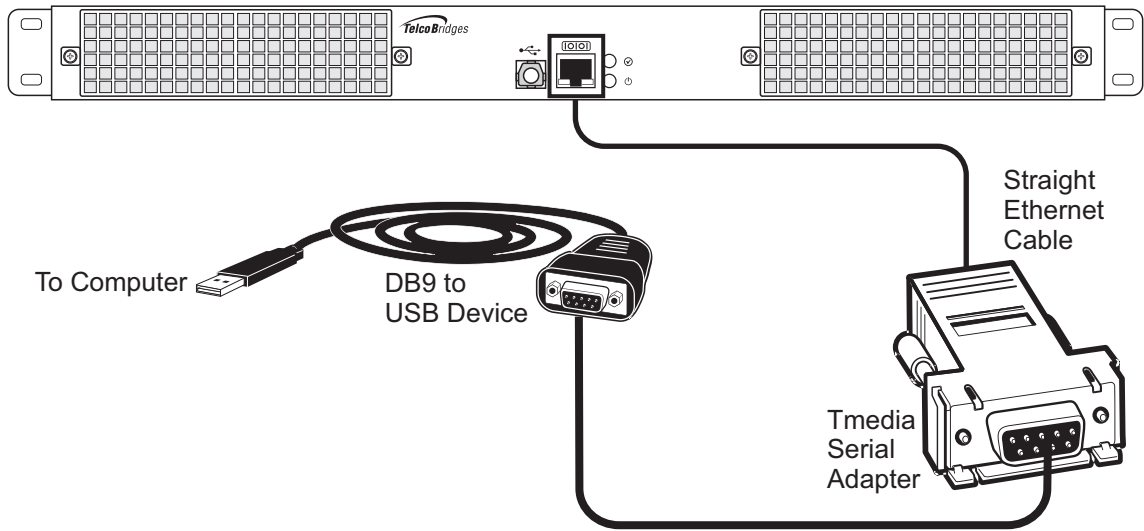

Figure 3.3 Conceptual View of a Serial Connection from the 3200 Series Gateway to a Computer

3.2.2 Configuring the Terminal Emulator Application

Before communicating with the management interface, you must first configure a terminal emulator or console application to communicate with the 3200 series system in order to configure initial settings. Available terminal emulation software includes:

- SecureCRT
- Putty
- Minicom

To configure the terminal emulator application:

1. Set the baud rate (bits per second) to **9600**
2. Set the data rate to **8 bits**
3. Set the parity to **None**
4. Set the stop bits to **1**
5. Set the flow control to **None**

Note See Section 3.5 on page 55 to learn how to change the IP address of the MGMT0 port.

3.3 Changing 3200 Series Gateway Management Port Passwords



Note The following procedure must be performed on 3200 series standalone and the 3200 series 1+1 system.

Once you are logged on to the 3200 series gateway, type “passwd”, to change the password being used. The following information will be displayed:

```
[root@TB003540 ~]# passwd

Changing password for user root.
New UNIX password:
Retype new UNIX password:
passwd: all authentication tokens updated successfully.
```

3.4 Retrieving 3200 Series Gateway Information

The 3200 series gateway enables you to retrieve system information with the following shell commands:

- `tbinfo` (retrieve the 3200 series gateway product type). See http://docs.telcobridges.com/mediawiki/index.php/TMG:Get_Product_Type, for further information.
- `tbserial` (retrieve the 3200 series gateway serial number). See http://docs.telcobridges.com/mediawiki/index.php/TMG:Get_Serial_Number, for further information.

3.5 Changing the 3200 Series Gateway Management Port IP Address

Note The following procedure must be performed on the 3200 series standalone unit and the 3200 series 1+1 system.

The management port of the 3200 series gateway (labeled MGMT0) is configured using a static IP address by default, which is located on the “Important Notice” sheet. It can be modified using the following shell script:

tbchangeip

Note If you do not have the “Important Notice” sheet, the default IP address and netmask are set as follows:

- IP address: 172.24.0.2
 - Netmask: 255.255.255.0
-



3.6 Setting the Time Zone



Note The following procedure must be performed on 3200 series standalone unit or the 3200 series 1+1 system.

You can change the time zone of the 3200 series gateway using the *tbtimezone* shell command.

3.7 Configuring the 3200 Series Gateway Using the Web Portal

Note: The first time that you connect to the web portal, you will need to configure the role of the 3200 series unit.

If your system features a 3200 series standalone unit, refer to Section 2.4.6 “Start Up” on page 25.

If your system features a 3200 series unit working in conjunction with a 3200 series +1 unit, refer to Section 2.5.7 “Start Up” on page 39.

To change the default configuration of a 3200 series gateway using the Web Portal, follow the steps described in the Web Portal System Configuration Tutorial Guide, found on the TBWiki:

<http://docs.telcobridges.com>

The Web Portal can be accessed with a Web browser. The default URL is: `http://[MGMT0 IP address]:12358`

Note 3200 series and 3200 series +1 units can access the Web Portal from either one of their IP addresses.

The default login information to access the Web Portal application is:

- Username: root
- Password: root

3.8 Changing VoIP Interface Addresses

The default address of the VoIP interfaces of the 3200 series gateway can be modified. To learn how this is done, refer to the Web Portal tutorial guide on the Telcobridges TB Wiki at docs.telcobridges.com.



Section 4 System Backups

This chapter provides information about the following topics:

- Section 4.1 “Creating a Database Backup”
- Section 4.2 “Downloading a Database Backup”
- Section 4.3 “Uploading a Database Backup”
- Section 4.4 “Restoring a Database Backup”



For more detailed information with regard to any of the points described in this section, please refer to the TBWiki: <http://docs.telcobridges.com>



4.1 Creating a Database Backup

It is important that backups be made of system configuration settings in the event of a system failure. It is recommended that a backup be made once the system has been configured. Backups are performed using the web portal.

4.2 Downloading a Database Backup

A backup of system data is stored locally on the hard drive of the 3200 series gateway. It is important that system backups be downloaded to an external storage device.

4.3 Uploading a Database Backup

An external backup of your database can be uploaded to your 3200 series gateway.

4.4 Restoring a Database Backup

In the event of a system failure requiring the replacement of a standalone 3200 series gateway, a previously saved backup of system settings can be restored to the new unit. A 1+1 system will automatically restore the backup.



Appendix A Wiring Diagrams



A.1

RJ48C Wiring Diagram: Crossover and Straight Cables

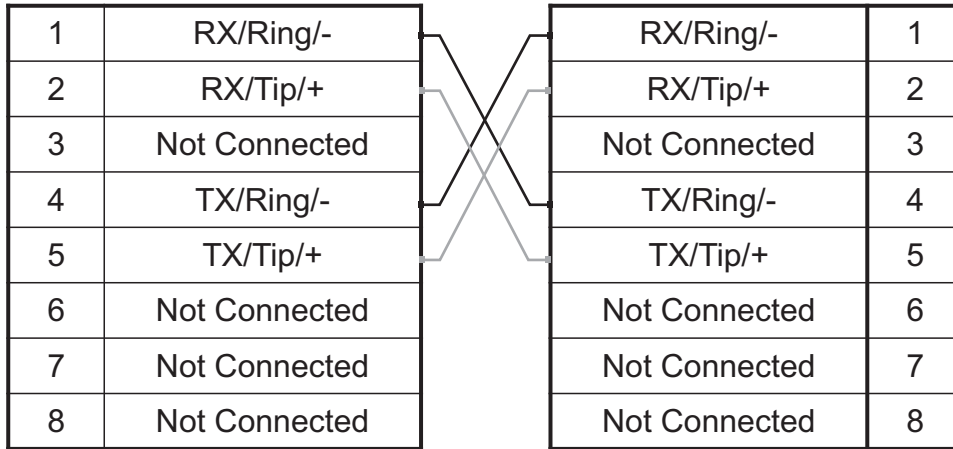
RJ 48 (T1/E1/J1) Wiring Schematic: Crossover Cable

1 8

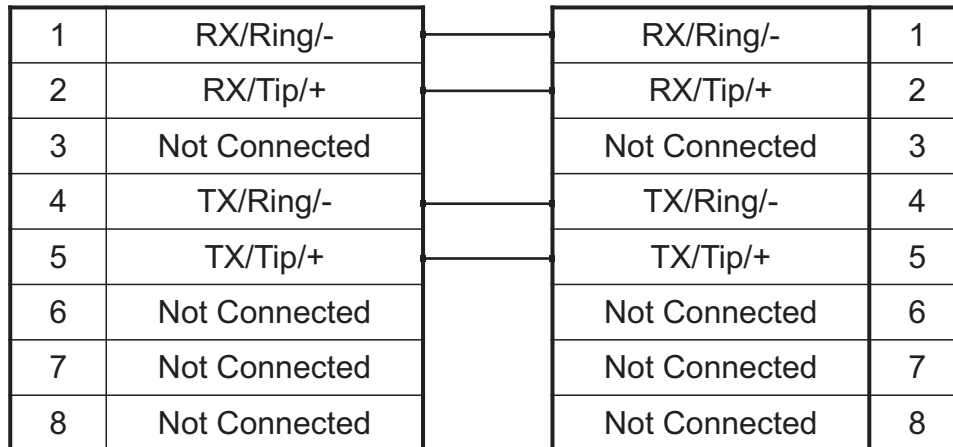
RJ 48 (T1/E1/J1) Wiring Schematic: Straight Cable

A.2 Tmedia Serial Adapter Wiring Diagram

