

TelcoBridges

Installation Guide

7800 Series Gateway

April 02, 2015



The information in this document as well as product specifications referred to throughout, are subject to change without notice. No part of this document may be reproduced or transmitted in any form or by any means, electronic or mechanical, for any purpose, without the express written permission of TelcoBridges. TelcoBridges may have patents or pending patent applications, trademarks, copyrights, or other intellectual property rights covering subject matter in this document. The furnishing of this document does not give you license to these patents, trademarks, copyrights, or other intellectual property except as expressly provided in any written license agreement from TelcoBridges Inc.

The information provided in this document is intended as a guide only. For the latest detailed engineering specifications, please contact TelcoBridges TB Support or visit the TBWiki: <http://docs.telcobridges.com>. TelcoBridges is committed to continually improving product designs; as a result, product specifications may be subject to change without notification.
© 2003-2015 TelcoBridges. All rights reserved.

TelcoBridges, Tmedia, TMG800, TMG3200, TMG3200-RJ, TMG3200-TE, TMG3200-DS3, TMG3200-STM1, TMG7800, TMG7800-TE, TMG7800-DS3, TMG7800-STM1, TMG7800-CTRL, TMG-CONTROL, TMG7800-TMS, Tsig, TSG800, TSG3200, TSG3200-RJ, TSG3200-TE, TSG3200-DS3, TSG3200-STM1, Ttrans, TMGIP800, TMGIP3200, TMGIP7800, Tmedia 1+1, Tmedia N+1, TMG800+1, TMG3200-TE+1, TMG3200-DS3+1, TMG3200-STM1+1, TMG7800-TE+1, TMG7800-DS3+1, TMG7800-STM1+1, Tdev, TMP800, TMP6400, TMP6400-CTRL, TMP6400-TMS, Tmonitor, TM1000, TM3000, Toopack, Toolpack API, TB640, TB-8, TB-16, and TB-Video, are trademarks of TelcoBridges Inc. All other trademarks are the property of their owners. This information is subject to change without notice.

Issue 2.0a

HEAD OFFICE

TelcoBridges Inc.
91 rue de la Barre, Suite 01
Boucherville, QC, J4B 2X6
CANADA
www.telcobridges.com

T +1 450 655 8993
F +1 450 655 9511
info@telcobridges.com

TB Support - Technical Support

Tel: +1 438 338 2100
support@telcobridges.com
www.telcobridges.com/en/tbsupport.aspx

Preface

About this Guide

This guide provides installation, and setup procedures for the 7800 series gateway.

Conventions

Terminology	Description
7800 series gateway	This term is used when a description applies to both a TMG7800 and the TMGIP7800 systems.
TMG7800 system	This term is used when a description applies to a TMG7800-CTRL, TMG7800 Telecom Unit and TMG7800-TMS.
TMGIP7800 system	This term is used when a description applies to a TMGIP7800-CTRL, TMGIP7800 Telecom Unit and TMGIP7800-TMS.
7800-CTRL	This term is used when a description applies to a TMG7800-CTRL and TMGIP7800-CTRL.
7800-TMS	This term is used when a description applies to a TMG7800-TMS and TMGIP7800-TMS.
TMG7800 +1	This term is used when a description applies to a TMG7800 that is selected to provide N+1 protection.
7800 N+1 patch panel	This term is used to refer to patch panels for TMG7800 systems that have N+1 protection.

Contact Us

If you have comments about this guide or any other TelcoBridges technical documentation, please send an email to marketing@telcobridges.com.

Table of Contents

Section 1	Introduction.....	1
1.1	Identifying the 7800 Series Gateway Equipment	2
1.2	Installation Prerequisites	5
1.2.1	7800-CTRL.....	5
1.2.2	7800 Series Telecom Units	6
1.2.3	7800-TMS.....	6
1.2.4	7800 N+1 Patch Panel	7
1.3	Preventing Electrostatic Discharge Damage.....	8
1.4	Recommended Reading.....	8
Section 2	Installation Preparations.....	9
2.1	Package Contents.....	10
2.1.1	7800-CTRL Gateway Controllers	10
2.1.2	7800 Series Telecom Unit.....	11
2.1.3	7800-TMS Media Switch	12
2.1.4	7800 N+1 Patch Panel	12
2.2	Rack Mounting the 7800 Series Gateway Equipment.....	13
2.2.1	Prerequisites	13
2.2.2	Vertical Placement of the Equipment	13
2.2.3	Installing the 7800 Series Gateway on an Equipment Rack	14
2.2.3.1	7800-CTRL.....	14
2.2.3.2	7800 Telecom Units	18
2.2.3.3	7800-TMS.....	18
2.2.3.4	7800 N+1 Patch Panel	18
Section 3	Installing the 7800-CTRL.....	19
3.1	Connecting to the 7800 Series Gateway Management Interface.....	20
3.2	Connecting to the 7800 Series Control Network	21
3.3	Powering Up.....	22
3.3.1	Connecting to AC Power	22
Section 4	Installing the 7800 Series Telecom Units.....	23
4.1	Connecting to the Control Network	24
4.2	Connecting to the VoIP Network(s).....	25
4.3	Connecting to the PSTN.....	26
4.3.1	SCSI Interface (T1/E1) for the TMG7800-TE	27
4.3.2	Dual BNC Interface (DS3) for the TMG7800-DS3.....	29
4.3.3	Optical Interface (OC3/STM-1) for the TMG7800-STM1.....	30
4.3.3.1	Standard (Without an N+1 Patch Panel).....	31
4.3.3.2	N+1 Protection (With an N+1 Patch Panel).....	31
4.4	Connecting to the TMS Network	32
4.4.1	Connecting to the TMG7800 Telecom Units	32

4.4.1.1	Prerequisites	32
4.4.1.2	Interconnections	32
4.4.2	Interconnecting Two 7800 Telecom Units	34
4.5	Grounding the Equipment Chassis.....	35
4.6	Powering Up.....	36
4.6.1	Connecting to AC Power	36
4.6.2	Connecting to DC Power.....	37
Section 5	Installing the 7800-TMS	39
5.1	Connecting to the Control Network	39
5.2	Grounding the Equipment Chassis.....	40
5.2.1	7800 TMS (Earlier Models)	40
5.2.2	7800 TMS (Later Models).....	41
5.3	Powering Up.....	42
5.3.1	Connecting to AC Power	42
5.3.2	Connecting to DC Power.....	43
5.4	TDM System Clock.....	44
Section 6	Installing the 7800 N+1 Patch Panel	45
6.1	Connecting Fiber Optic Cables to the 7800 N+1 Patch Panel	46
6.2	Connecting to the Control Network	48
6.3	Grounding the Equipment Chassis.....	49
6.4	Connecting to AC Power	50
Section 7	Start Up and Verification	51
7.1	Start Up	51
7.2	Verifying the LED Status Indications	52
7.2.1	7800-CTRL.....	52
7.2.1.1	Operator Information Panel-Front of Unit.....	52
7.2.1.2	Power Supply-Rear of Unit.....	53
7.2.2	7800 Telecom Unit	54
7.2.3	7800-TMS.....	55
7.2.4	7800 N+1 Patch Panel	56
Section 8	Powering Down the Equipment.....	57
8.1	7800-CTRL.....	57
8.2	7800 Telecom Unit	57
8.3	7800-TMS.....	57
8.4	7800 N+1 Patch Panel	57
Section 9	Initial System Configuration.....	59
9.1	Connecting to the 7800-CTRL Console	60
9.2	Configuring the Terminal Emulator Application	61
9.3	Connecting to the 7800 Series Gateway.....	62
9.4	Retrieving 7800 Series Gateway Information.....	62

9.5	Changing the 7800 Series Gateway Management Port IP Address	62
9.6	Changing 7800 Series Gateway Management Port Passwords	63
9.7	Setting the Time Zone	63
9.8	Configuring the 7800 Series Gateway Using the Web Portal.....	63
9.9	Changing VoIP Interface Addresses	63
Section 10	System Backups.....	65
10.1	Creating a Database Backup	66
10.2	Downloading a Database Backup	66
10.3	Uploading a Database Backup.....	66
10.4	Restoring a Database Backup.....	66
Appendix A	Wiring Diagrams.....	67
A.1	RJ48C Wiring Diagram: Crossover and Straight Cables.....	68
A.2	RJ48 Console Wiring Diagram	69

Section 1 Introduction

This section provides an introduction to the installation and setup of a 7800 Series Gateway:

The following topics are covered:

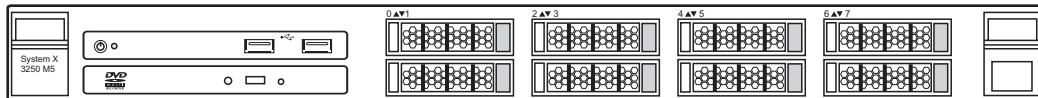
- Section 1.1 “Identifying the 7800 Series Gateway Equipment”
- Section 1.2 “Installation Prerequisites”
- Section 1.3 “Preventing Electrostatic Discharge Damage”
- Section 1.4 “Recommended Reading”

1.1 Identifying the 7800 Series Gateway Equipment

The 7800 series gateway is comprised of the following equipment:

- One or two 7800-CTRL gateway controller(s). See figure 1.1 on page 2.
- One to sixteen 7800 Telecom Unit(s). See figure 1.2 on page 3.
- Based upon the configuration of your 7800 series gateway, the number of 7800-TMS media switch(es) may range from zero to two. See figure 1.3 on page 4.
- If the 7800 series gateway employs N+1 protection, one to two 7800 N+1 patch panels are used to provide protection for the TDM network. See figure 1.4 on page 4.

TMG7800-CTRL/TMGIP7800-CTRL (front view)

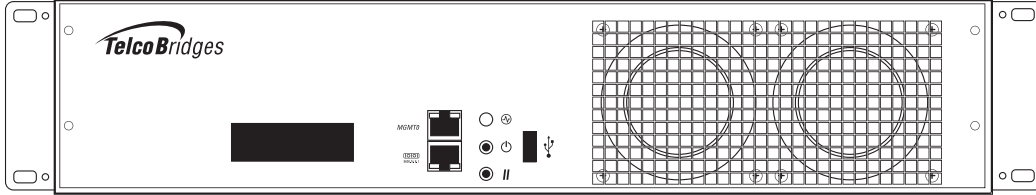


TMG7800-CTRL/TMGIP7800-CTRL (rear view)

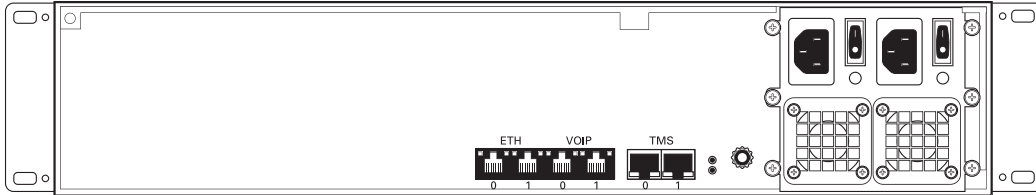


Figure 1.1 7800-CTRL

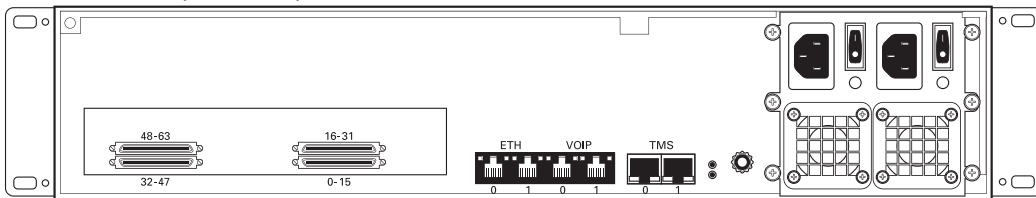
TMG7800 Telecom Unit/TMGIP7800 Telecom Unit (front view)



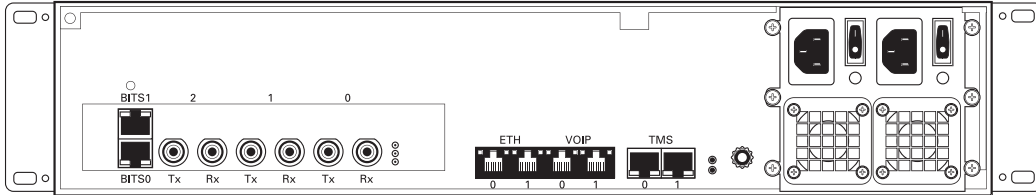
TMGIP7800 (rear view)



TMG7800-TE (rear view)



TMG7800-DS3 (rear view)



TMG7800-STM1 (rear view)

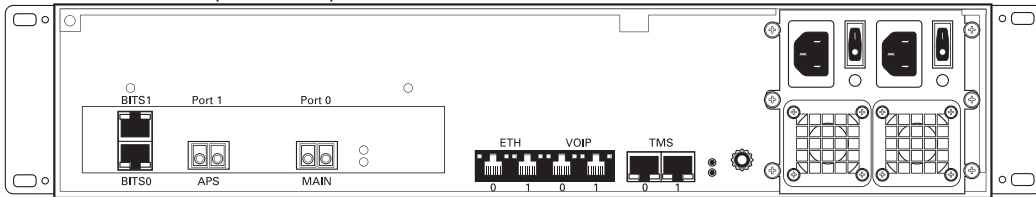
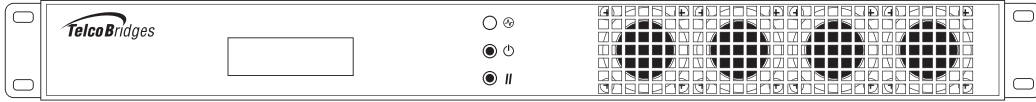
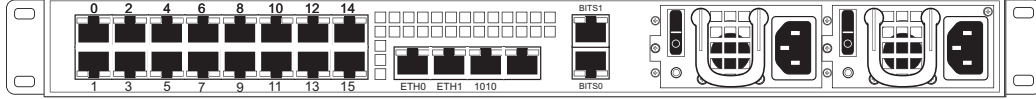


Figure 1.2 7800 Series Telecom Units

TMG7800-TMS/TMGIP7800-TMS Unit (front view)



TMG7800-TMS/TMGIP7800-TMS Unit - (earlier models rear view)



TMG7800-TMS/TMGIP7800-TMS Unit - (later models rear view)

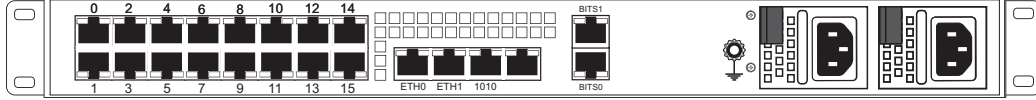


Figure 1.3 7800-TMS

7800 N+1 Patch Panel (rear view)

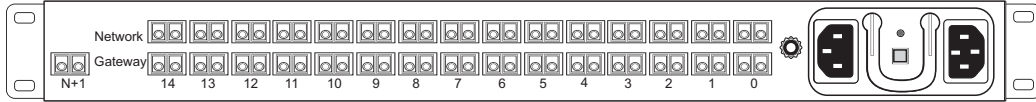


Figure 1.4 7800 N+1 Patch Panel

1.2 Installation Prerequisites

For the installation to proceed without interruption, it is important that you verify that you have all necessary materials on hand.

1.2.1 7800-CTRL

Adequate space for the installation of the 7800-CTRL

You will need to mount the 7800-CTRL on a 19" equipment rack (customer provided). Your 7800-CTRL is a 1U unit. Plan for an additional 1U space on the equipment rack for a redundant 7800-CTRL. A TMG7800 system can range in size from 3 to 38U in vertical rack space.

Note The depth of the 7800-CTRL is 22.68" (576mm), instead of the 16" (406mm) depth of the TMG7800 telecom units. It is important to plan for an equipment rack of adequate size.

The dimension of the TMG7800-CTRL are as follows:

- Depth x Width x Height (mm) 576 x 434 x 43
- Depth x Width x Height (inch) 22.68 x 17.11" x 1.69"

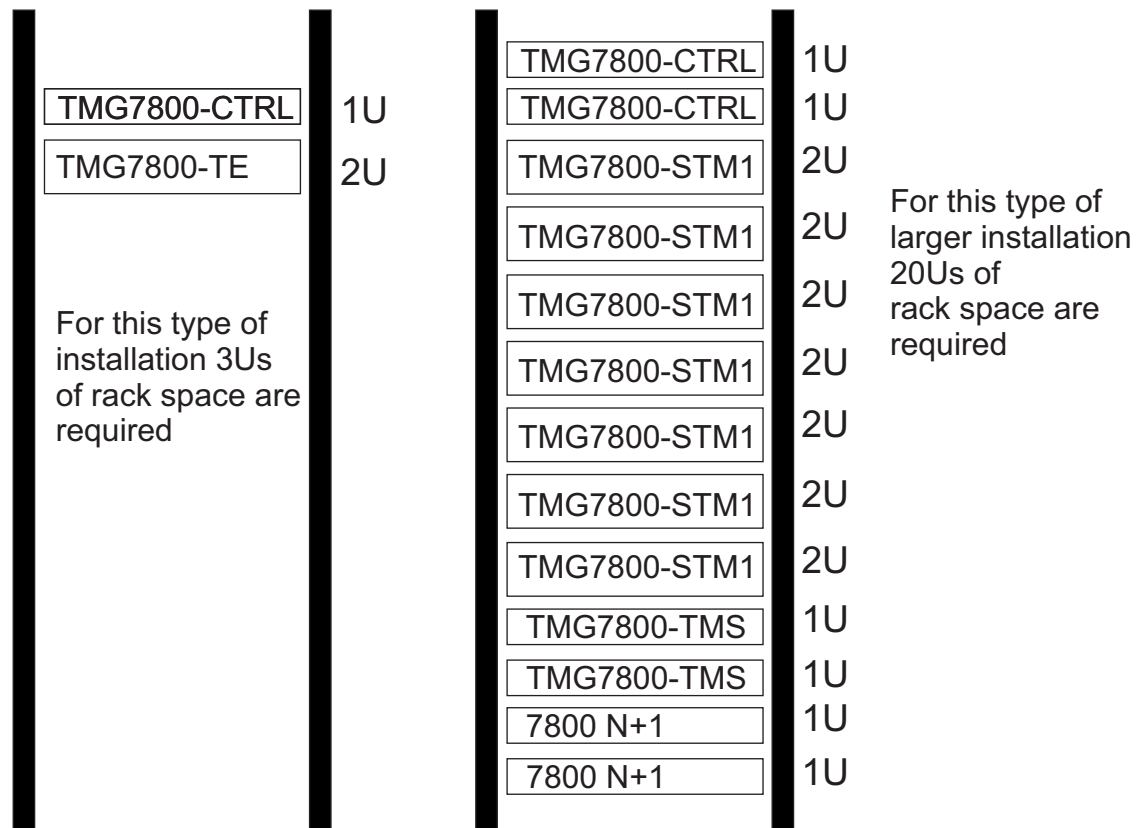


Figure 1.5 Example of an equipment rack-space allocation

Adequate power supply and power connections

Each 7800-CTRL requires two power connections to provide for its redundant power supply. To guarantee an uninterrupted supply of electricity, each power connection must be fed by a dedicated power source.

An IP address for the management port

Each 7800-CTRL requires a IP address for the management port. To avoid delays, you should have the IP address, netmask and gateway addresses on hand. Take note that the management port supports DHCP, see Section 3.1 “Connecting to the 7800 Series Gateway Management Interface” on page 20 for further information.

Cabling

Three customer supplied Ethernet cables are required for each 7800-CTRL, to connect the 7800-CTRL to the switches.

1.2.2 7800 Series Telecom Units

Adequate space for the installation of each 7800 Series Telecom Unit

You will need to mount each 7800 Series Telecom Unit (1-16 units) on a 19" equipment rack (customer provided). Each 7800 Series Telecom Unit is housed in a 2U chassis.

Adequate power supply and power connections

Each 7800 Series Telecom Unit requires two power connections to provide for its redundant power supply.

To guarantee an uninterrupted supply of electricity, each power connection must be fed by a dedicated power source.

1.2.3 7800-TMS

Adequate space for the installation of the 7800-TMS

You will need to mount the 7800-TMS on a 19" equipment rack (customer provided). Your 7800-TMS is a 1U unit. Plan for an additional 1U space on the equipment rack for a redundant 7800-TMS.

Adequate power supply and power connections

Each 7800-TMS requires two power connections to provide for its redundant power supply. To guarantee an uninterrupted supply of electricity, each power connection must be fed by a dedicated power source.

1.2.4 7800 N+1 Patch Panel

Adequate space for the installation of the 7800 N+1 Patch Panel

If your system employs N+1 protection, you will need to mount the 7800 N+1 patch panel on a 19" equipment rack (customer provided). Your 7800 N+1 patch panel is a 1U unit. If your system is using Automatic Protection Switching (APS), plan for an additional 1U space on the equipment rack for a second 7800 N+1 patch panel.

Adequate power supply and power connections

Each 7800 N+1 patch panel requires two power connections to provide for its redundant power supply. To guarantee an uninterrupted supply of electricity, each power connection must be fed by a dedicated power source.

1.3 Preventing Electrostatic Discharge Damage

Electrostatic discharge (ESD) can damage equipment and impair electrical circuitry. It may occur if electronic printed circuit cards are improperly handled and may cause complete or intermittent failure.



Always follow ESD prevention procedures when removing and replacing modules:

- Ensure that the Tmedia VoIP gateways are grounded.
 - Wear an ESD-preventive wrist strap and ensure that it makes good contact with your skin. Connect the wrist strap clip to an unpainted surface of the Tmedia VoIP Gateway or the grounded equipment rack in order to channel away all ESD voltage safely to ground. To guard against ESD damage and shocks, the wrist strap and cord must be in proper working condition.
 - If no wrist strap is available, and you must work with Tmedia VoIP Gateways, ground yourself by touching a metal part of the chassis.
-

1.4 Recommended Reading

This document assumes that you have a clear understanding of the installation of this equipment and have been trained to work with it. If you have any technical questions, TelcoBridges TB Support (technical support team) can be reached via telephone (+1 866 438 4703) or email: support@telcobridges.com.

Documents exploring various aspects of the Tmedia system are available on the TB Wiki: <http://docs.telcobridges.com>

Section 2 Installation Preparations

This section provides information about the following topics:

- Section 2.1 “Package Contents”
- Section 2.2 “Rack Mounting the 7800 Series Gateway Equipment”

2.1 Package Contents

Depending on your system requirements, you may receive one or more of the following items:

- Section 2.1.1 “7800-CTRL Gateway Controllers” on page 10.
- Section 2.1.2 “7800 Series Telecom Unit” on page 11.
- Section 2.1.3 “7800-TMS Media Switch” on page 12.
- Section 2.1.4 “7800 N+1 Patch Panel” on page 12.

The contents of these devices are described in the following sections.

2.1.1 7800-CTRL Gateway Controllers

In the box, you will find the following items:

- One 7800-CTRL (TMG7800-CTRL or TMGIP7800-CTRL). See figure 1.1 on page 2.
- Two hard drives.
- Two power cords.
- One Product Warranty.
- One Important Notice (two-sided document containing pertinent product serial numbers and other important information).
- One packing slip.
- One set of sliding rails and associated screws.
- One set of brackets and associated screws.

Not included

- Ethernet cables.

2.1.2 7800 Series Telecom Unit

In the box, you will find the following items:

- One 7800 series unit (TMGIP7800, TMG7800-TE, TMG7800-DS3, or TMG7800-STM1). See figure 1.2 on page 3.
- One set of mounting brackets and screws, used to mount the 7800 series telecom unit to a 19" rack.
- One Tmedia serial adapter to interface with the serial port of your computer with the RJ-45 port of the 7800 series telecom unit.
- Three CAT5 Ethernet (blue) straight cables (male-male), 3 meters in length.
- One Important Notice (two-sided document containing pertinent product serial numbers, and other important information).
- One Product Warranty.
- One packing slip.
- Two AC or DC power cables

Specifically with the TMG7800-TE, you will also have:

- One or two patch panel(s)
- Two SCSI cables per patch panel.

Not included

- A 19" equipment rack. The 7800 series telecom unit must be installed on a 19" wide equipment rack.

2.1.3 7800-TMS Media Switch

Note The 7800-TMS that you receive may feature visually different power supplies. This difference is shown in figure 1.3 on page 4.

In the 7800-TMS media switch box, you will find the following items:

- One 7800-TMS unit (TMG7800-TMS or TMGIP7800-TMS). See figure 1.3 on page 4.
- Three CAT5 Ethernet (blue) straight cables (male-male), 3 meters in length.
- One Tmedia serial adapter to interface with the serial port of your computer with the RJ-45 port of the 7800-TMS.
- One set of mounting brackets and screws, used to mount the TMG7800-TMS to a 19" rack.
- One Important Notice (two-sided document containing pertinent product serial numbers, and other important information).
- One Product Warranty.
- One packing slip.
- Two AC or DC power cables

Not included

- A 19" equipment rack. The 7800-TMS must be installed on a 19" wide equipment rack.

2.1.4 7800 N+1 Patch Panel

In the 7800 N+1 Patch Panel box, you will find the following items:

- One 7800 N+1 patch panel. See figure 1.4 on page 4.
- Three CAT5 Ethernet (blue) straight cables (male-male), 3 meters in length.
- One Tmedia serial adapter to interface with the serial port of your computer with the RJ-45 port of the 7800 N+1 patch panel.
- One set of mounting brackets and screws, used to mount the 7800 N+1 patch panel to a 19" rack.
- Two AC or DC power cables
- One packing slip.
- One Important Notice (two-sided document containing pertinent product serial numbers, and other important information).
- One Product Warranty.

Not included

- Optic fibers (They can be purchased from TelcoBridges).
- A 19" equipment rack. The 7800 N+1 patch panel must be installed on a 19" wide equipment rack.

2.2 Rack Mounting the 7800 Series Gateway Equipment

The 7800 series equipment is mounted on a customer provided equipment rack using the mounting hardware packaged in each box.

2.2.1 Prerequisites

To rack mount the equipment, you will need:

- One customer-provided equipment rack, measuring 19" in width and 31.5" in depth. The rack must be solidly anchored to the floor with appropriate support at the top of the racks.
- Climate controlled room: 0 to +50 Celsius, 0 to 95% non-condensing humidity.

2.2.2 Vertical Placement of the Equipment

The 7800-CTRL and 7800-TMS are each housed in 1U chassis, while 7800 Telecom units are housed in 2U chassis, as tabulated in table 2.1 on page 13. It is important that you provide for enough room on the equipment rack to allow for the installation of the equipment.

Consider the available space on your equipment rack and the height of one or two 7800-CTRL unit(s), one to sixteen 7800 Telecom unit(s), and from zero to two TMG7800-TMS units. Due to the rear-exhaust heat vents and the efficient heat dissipation design, there is no need to leave any physical vertical space above or below the 7800-CTRL unit(s), 7800 N+1 patch panel(s), 7800 Telecom unit(s), and the 7800-TMS unit(s) on the equipment rack.

Table 2.1 Tmedia VoIP Gateway Physical Height

Tmedia Model Number	Vertical Height
7800-CTRL	1U (1.75 inches or 44.45 mm)
7800 Telecom Unit	2U (3.5 inches or 89.10 mm)
7800-TMS	1U (1.75 inches or 44.45 mm)
SCSI Patch Panels	1U (1.75 inches or 44.45 mm)
7800 N+1 Patch Panels	1U (1.75 inches or 44.45 mm)

2.2.3 Installing the 7800 Series Gateway on an Equipment Rack

The 7800-CTRL, 7800 Telecom Unit, and 7800-TMS are mounted on a 19" equipment rack using the angle brackets and screws provided in the box.

2.2.3.1 7800-CTRL

Mounting the 7800-CTRL Unit(s):

The 7800-CTRL is installed in a 19" equipment rack on slider rails as follows:

1. Install the left sliding rail on the left-hand side of the equipment rack.
 - 1a. Attach the front end of the slider rail to the front edge of the equipment rack. See figure 2.1 on page 14.
 - 1b. Attach the rear end of the slider rail to the rear edge of the equipment rack. See figure 2.2 on page 15 and figure 2.3 on page 15.
2. Repeat Step 1 to install the right sliding rail on the right-hand side of the equipment rack.
3. Extend both sliding rails. See figure 2.4 on page 16.
4. Attach the 7800-CTRL to the rails. See figure 2.5 on page 16 and figure 2.6 on page 17.
5. Push the 7800-CTRL back into the equipment rack until it locks into place.

Note To unlock the rails and slide the T800-CTRL outwards from the equipment rack, depress the purple colored buttons on each side of the sliding rails.

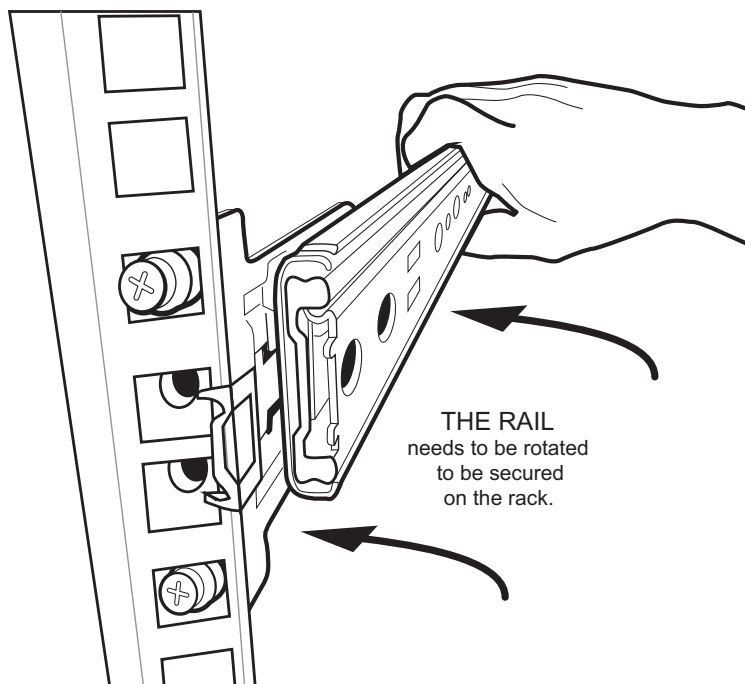


Figure 2.1 Securing the Slider Rail to the Front of the Equipment Rack

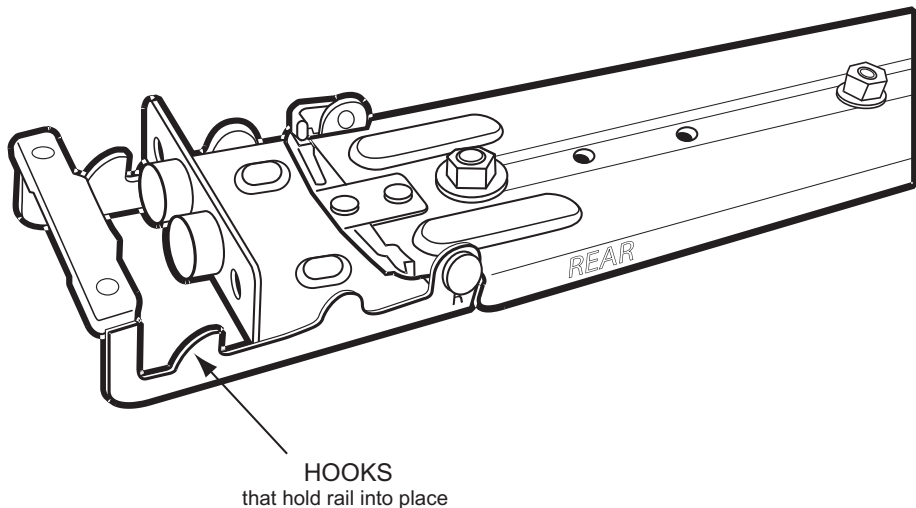


Figure 2.2 Detail View of Slider Rail Rear Retaining Hooks

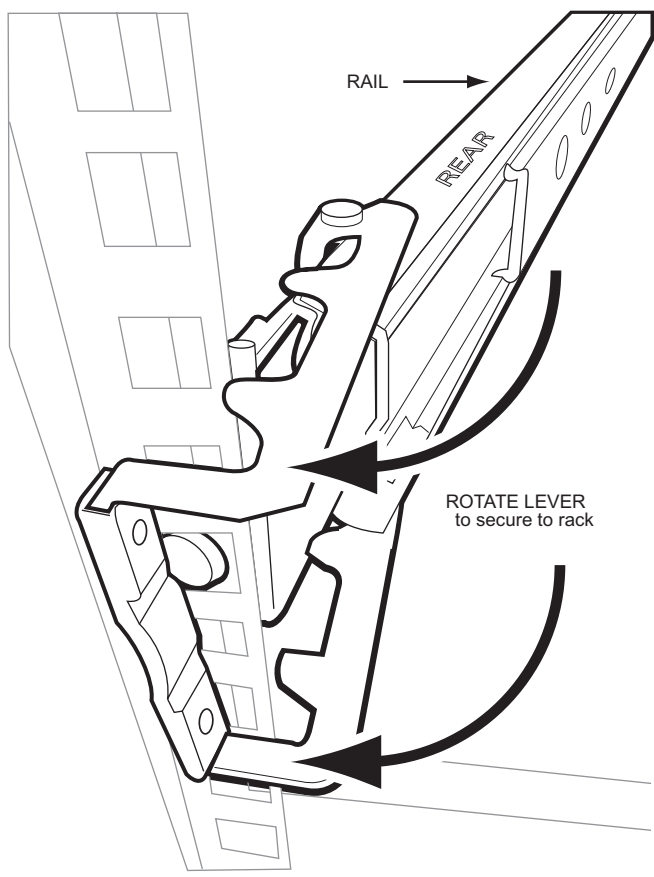


Figure 2.3 Detailed View of Slider Rail Rear Retaining Hooks being Locked onto the Rear of the Equipment Rack

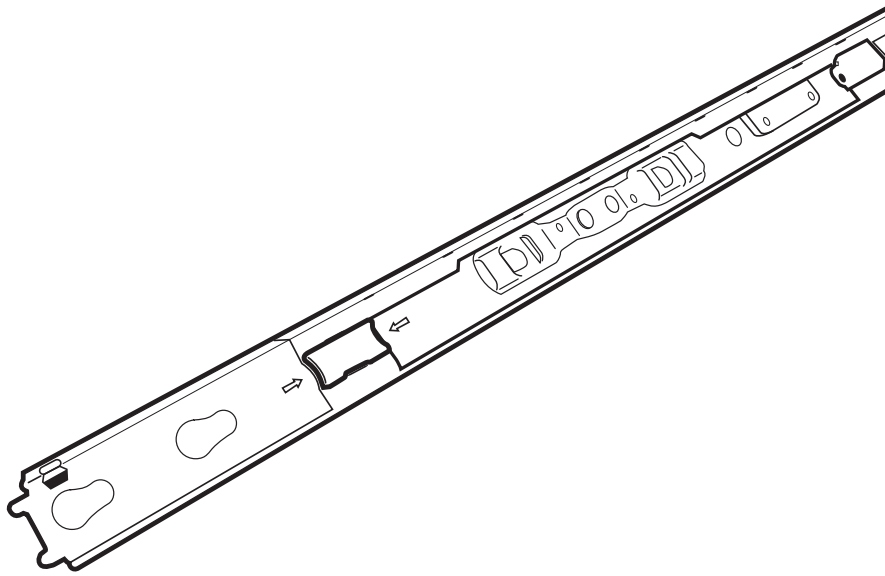


Figure 2.4 Detailed View of the Slider Rail Release Mechanism

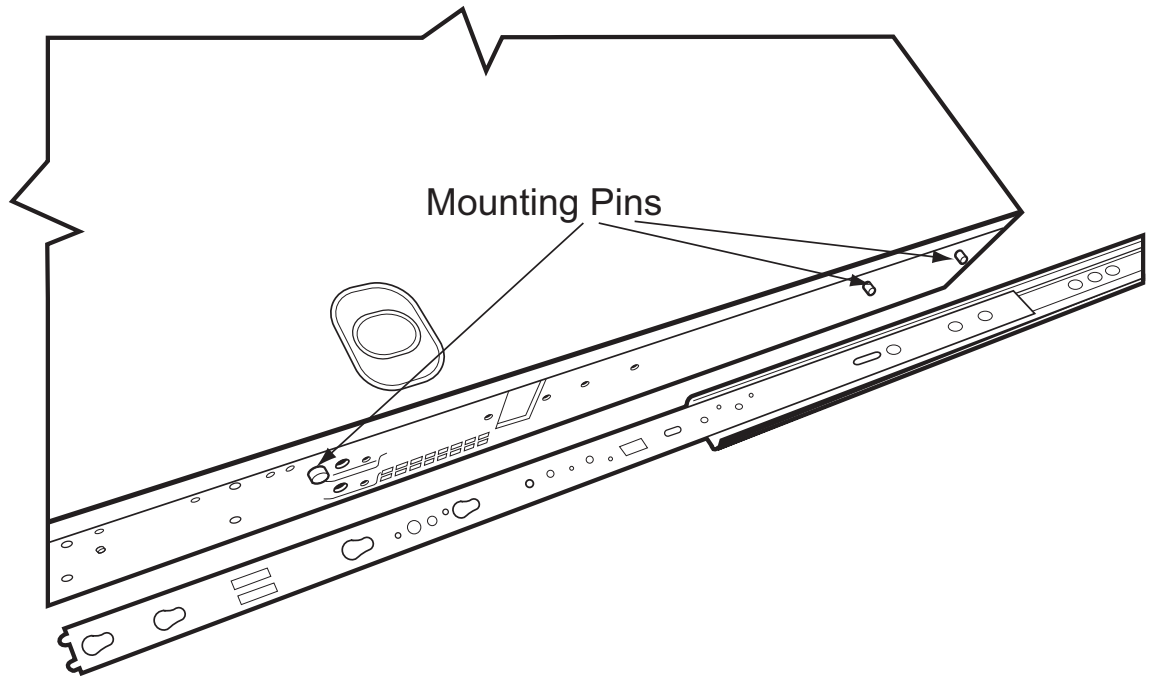


Figure 2.5 Attaching Sliding Rails to the 7800-CTRL Mounting Pins

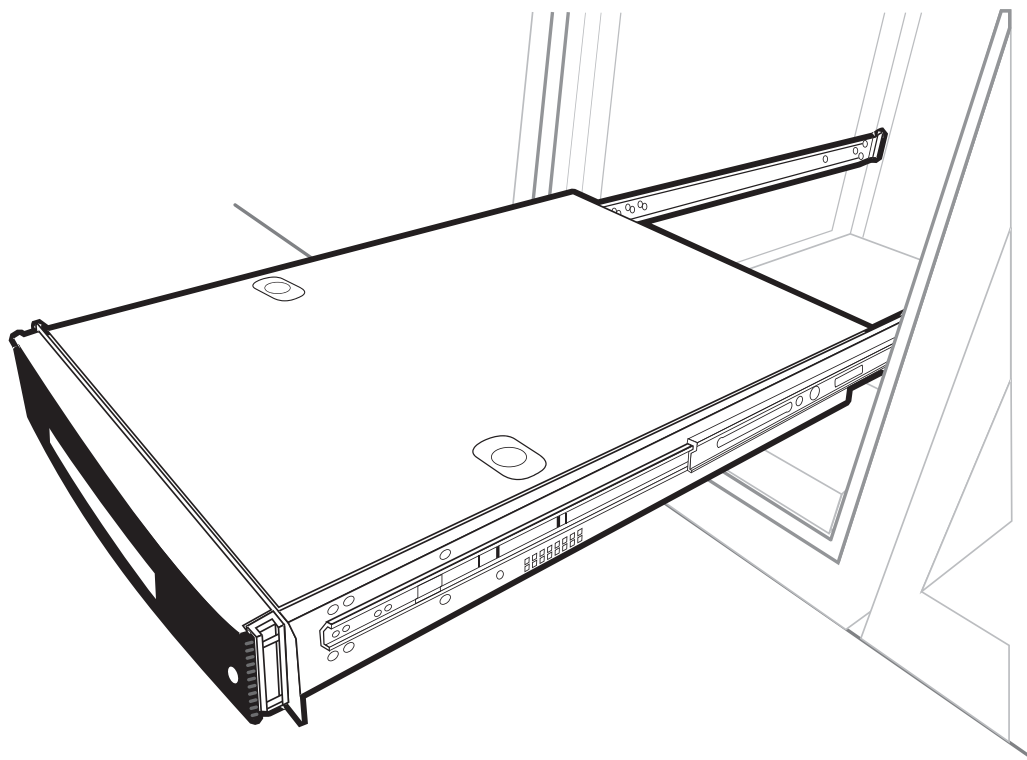


Figure 2.6 7800-CTRL Installed on Slider Rails in the Fully Extended Position

2.2.3.2 7800 Telecom Units

Mounting the 7800 Telecom Unit(s)

1. Using four metal screws, attach one angle bracket to the front, left-hand side of the 7800 Telecom Unit, when viewed from the front. Do the same for the angle bracket on the right-hand side.
2. Start mounting equipment beneath the 7800-CTRL, keeping in mind the space required on the equipment rack as described in Section 2.2.2 “Vertical Placement of the Equipment” on page 13.
3. Repeat steps 1 and 2 for each additional 7800 Telecom Unit.

Note If you are installing TMG7800-TE units you will require one to two patch panels per TMG7800-TE. Mount the patch panels beneath each TMG7800-TE.

2.2.3.3 7800-TMS

Mounting the 7800-TMS Unit(s):

1. Using four metal screws, attach one angle bracket to the front, left-hand side of the 7800-TMS, when viewed from the front. Do the same for the angle bracket on the right-hand side.
2. Start mounting equipment beneath the last 7800 Telecom Unit, keeping in mind the space required on the equipment rack as described in Section 2.2.2 “Vertical Placement of the Equipment” on page 13.
3. Repeat steps 1 and 2 for a second 7800-TMS.

2.2.3.4 7800 N+1 Patch Panel

Mounting the 7800 N+1 Patch Panel(s):

1. Using four metal screws, attach one angle bracket to the front, left-hand side of the 7800 N+1 patch panel, when viewed from the front. Do the same for the angle bracket on the right-hand side.
2. Start mounting this equipment beneath the last 7800-TMS, keeping in mind the space required on the equipment rack as described in Section 2.2.2 “Vertical Placement of the Equipment” on page 13.
3. Repeat steps 1 and 2 for a second 7800 N+1 patch panel.

Section 3 Installing the 7800-CTRL

This section covers the following procedures:

- Section 3.1 “Connecting to the 7800 Series Gateway Management Interface” on page 20.
- Section 3.2 “Connecting to the 7800 Series Control Network” on page 21.
- Section 3.3 “Powering Up” on page 22.

3.1 Connecting to the 7800 Series Gateway Management Interface

The 7800 series gateway management interface enables administrators to perform management tasks on a 7800-CTRL.

Prerequisites

To communicate with the management interface, the following is needed:

- One CAT5 Ethernet cable with RJ45 male-male terminations.

Note Ethernet cables are not supplied with the 7800-CTRL.

To communicate with the Management Interface:

1. Connect an RJ45 cable from the 7800-CTRL to a Gigabit Ethernet switch.

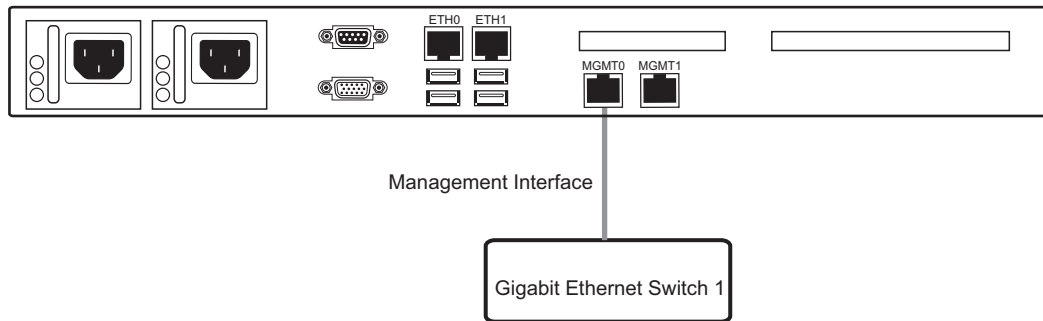


Figure 3.1 7800-CTRL System Management Interface

3.2 Connecting to the 7800 Series Control Network

The 7800 Series Control network enables communication between the 7800-CTRL, the 7800 Telecom Unit(s), and the 7800-TMS.

Prerequisites

To connect the 7800-CTRL to the control network, you will need:

- Two CAT5 Ethernet cables with RJ45 male-male terminations.

Connections

The 7800-CTRL is connected to the control network using two CAT5 Ethernet cables, as shown in figure 3.2 on page 21.

To connect to the control network:

1. Connect the ETH0 connector on the 7800-CTRL to the Control network switch one.
2. Connect the ETH1 connector on the 7800-CTRL to the Control network switch two.

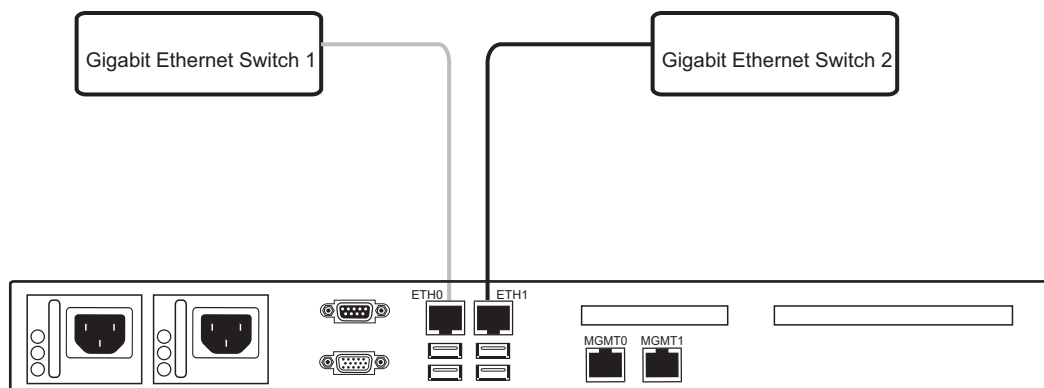


Figure 3.2 Connecting to the Control Network

3.3 Powering Up

The 7800-CTRL is furnished with two AC or two DC power connections. Only once all other equipment installation work has been completed should the Tmedia VoIP gateway be powered up.

Prerequisites

To power the 7800-CTRL, you will need:

- Two independent AC or DC power sources.
- Two power cables.

3.3.1 Connecting to AC Power

The 7800-CTRL is furnished with two AC power connectors.

To connect the TMG7800-CTRL to AC Power:

1. Connect the first power connector of the 7800-CTRL to the first power source. See Figure 3.3.
2. Connect the second power connector of the 7800-CTRL to the second power source.

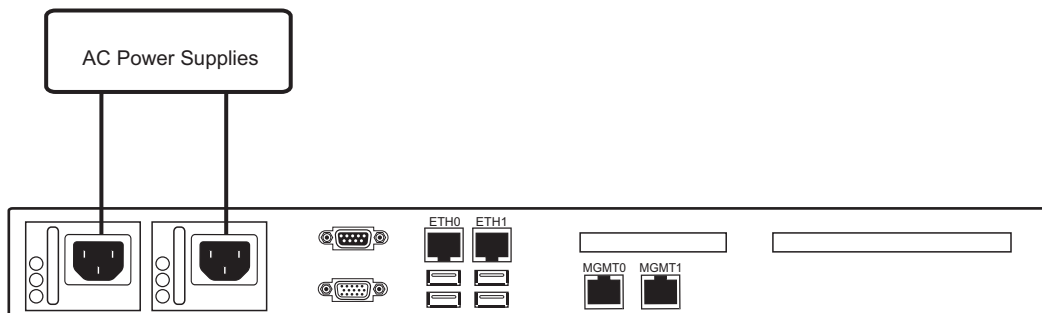


Figure 3.3 7800-CTRL AC Power Connections

Section 4 Installing the 7800 Series Telecom Units

This section covers the following procedures:

- Section 4.1 “Connecting to the Control Network” on page 24.
- Section 4.2 “Connecting to the VoIP Network(s)” on page 25.
- Section 4.3 “Connecting to the PSTN” on page 26.
- Section 4.4 “Connecting to the TMS Network” on page 32.
- Section 4.5 “Grounding the Equipment Chassis” on page 35.
- Section 4.6 “Powering Up” on page 36.

4.1 Connecting to the Control Network

The 7800 Series Control network enables communication between the 7800-CTRL, the 7800 Telecom unit(s), the 7800-TMS, and 7800 N+1 patch panel(s).

Prerequisites

To connect the 7800 Telecom unit(s), you will need:

- Two CAT5 Ethernet cables with RJ45 male-male terminations for each 7800 Telecom unit.

Connections

The 7800 Telecom unit(s) are connected to the control network using two CAT5 Ethernet cables, as shown in figure 4.1 on page 24.

To connect to the control network:

1. Connect the ETH0 connector on the 7800 Telecom unit to the control network switch one.
2. Connect the ETH1 connector on the 7800 Telecom unit to the control network switch two.
3. Repeat steps 1 and 2 for each additional 7800 Telecom Unit.

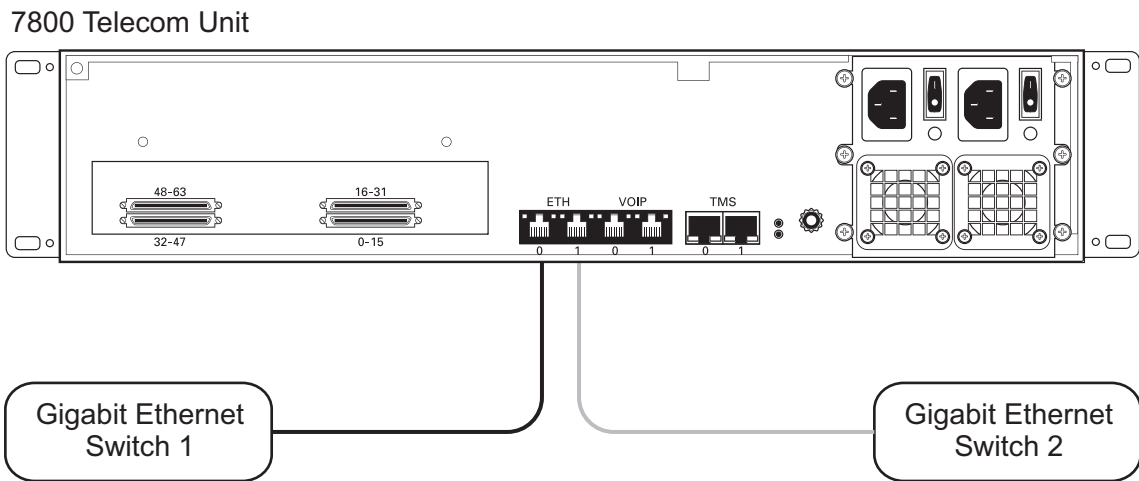


Figure 4.1

Connecting to the Control Network

4.2 Connecting to the VoIP Network(s)

Each 7800 Telecom unit features dual GigE ports for connection to different VoIP networks. This provides an access point to manage VoIP traffic. Should one of the IP networks fail, the 7800 Telecom Units will continue to manage VoIP traffic using the alternate network.

The IP address of the VoIP ports can be modified using the web portal.

Note: The 7800 Telecom Units require two (2) gigabit layer 2 Ethernet switches.

Prerequisites

To connect the 7800 Telecom units to the VoIP network, you will need:

- Two gigabit layer 2 Ethernet switches. A second one is required to support redundancy of the VoIP interface.
- Two CAT5 Ethernet cables with RJ45 male-male terminations.
- Two IP addresses located on different subnets.

Connections

The 7800 Telecom units are connected to the VoIP network through two Ethernet GigE network links, as shown in figure 4.2 on page 25.

To connect to the VoIP network:

1. Connect the VoIP0 connector from each 7800 Telecom unit to the first Ethernet switch.
2. Connect the VoIP1 connector from each 7800 Telecom unit to the second Ethernet switch.

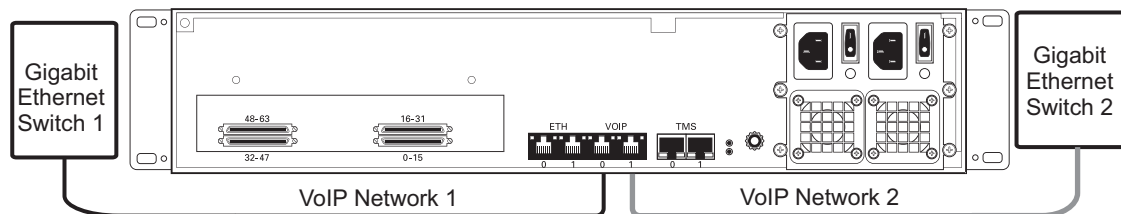


Figure 4.2 Connecting to the VoIP Network

4.3 Connecting to the PSTN

The 7800 Telecom Units feature a variety of interfaces to the PSTN network.

Note This section only applies to the TMG7800 system.

Prerequisites

To connect to the PSTN network, you must comply with one of the following:

- Your TMG7800-TE features SCSI connectors for connection to T1/E1 lines. You will require one patch panel for each 32 line grouping of T1/E1 line interfaces with 2 SCSI cables per patch panel (supplied). Each T1/E1 line interfaces requires a RJ48C to connect to the PSTN (not supplied).
- Your TMG7800-DS3 features BNC connectors for connection to DS3 lines. You will require two coaxial cables for each DS3 interface.
- Your TMG7800-STM1 features electrical or optical STM-1 connectors. You will require two fiber optic cables for each STM-1 interface.

4.3.1 SCSI Interface (T1/E1) for the TMG7800-TE

A TMG7800-TE with 4 SCSI connectors enables the connection to T1/E1 lines. The termination impedance is set at 120 ohms. It is possible to connect an external balun in order to convert to 75 ohms.

Note All ports may not be active. T1/E1 ports are activated by software license; the number of active ports depends on the licenses purchased.

Patch panels use straight connections. In other words, they do not cross the RX and TX signals. Connections between the patch panels and the TMG7800 require straight cables. The supplied SCSI cables are straight cables. Cables used to connect the network to the patch panel must do the cross connection.

To connect the TMG7800-TE to the PSTN:

1. Start with SCSI ports 0-15 located at the bottom right as shown in figure 4.3 on page 28. Connect one SCSI cable between this port and SCSI patch panel number 1, ports 0-15. Connect SCSI ports 16-31 to patch panel number 1, ports 16-31.
2. Repeat step 1, using lines 32-63 and a second patch panel. Connect lines 32-47 to patch panel 2, ports 0-15. Connect lines 48-63 to patch panel 2, ports 16-31.

TMG7800-TE

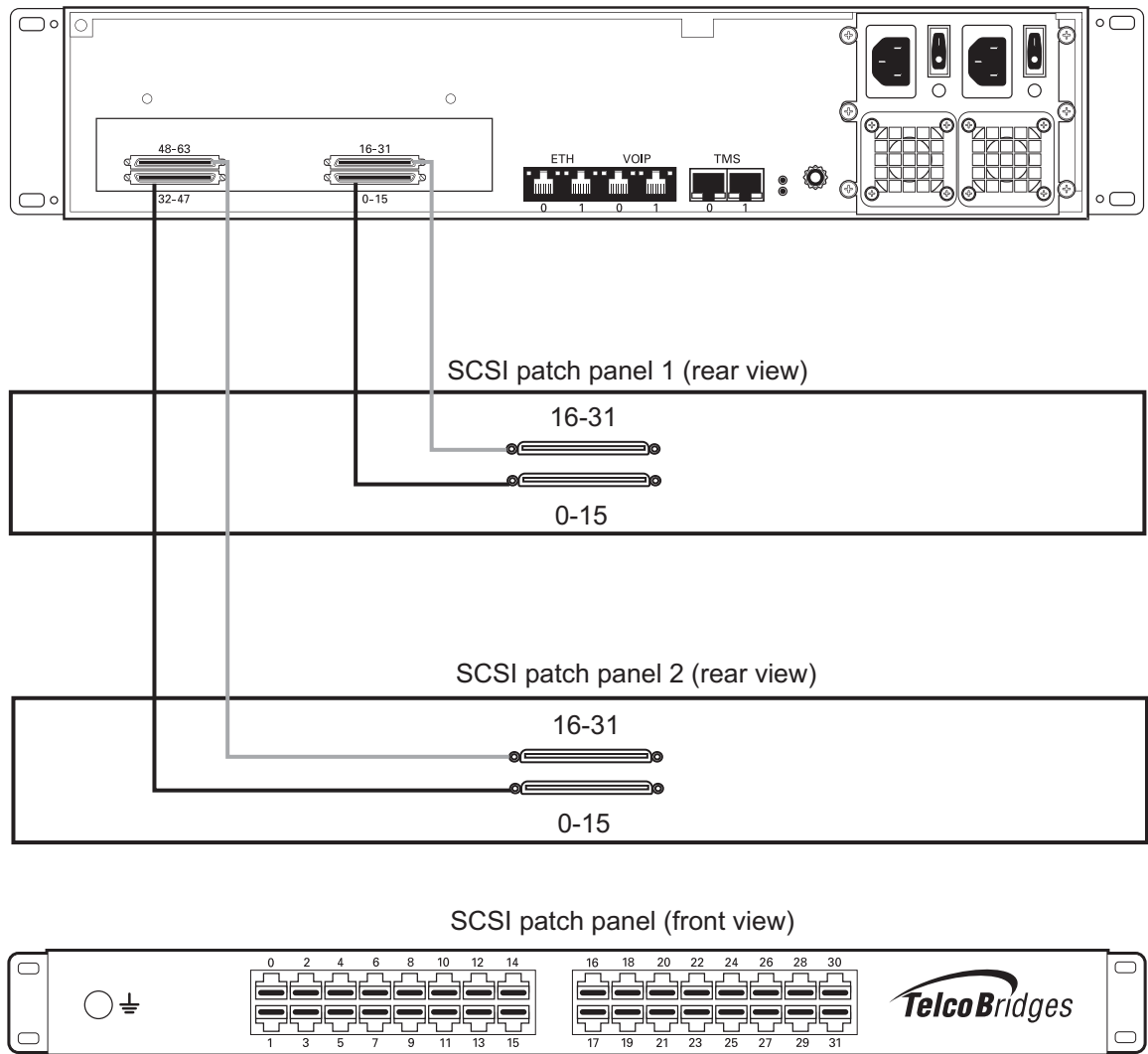


Figure 4.3 TMG7800-TE with SCSI connectors

4.3.2 Dual BNC Interface (DS3) for the TMG7800-DS3

A TMG7800-DS3 with 3 sets of BNC connectors enables the connection to DS3 lines. See figure 4.4 on page 29.

Note All ports may not be active. DS3 ports are activated by software license; the number of active ports depends on the licenses purchased.

To connect the TMG7800-DS3 to the PSTN:

1. Start with the Dual BNC port pair #0 (right-most) as shown in figure 4.4 on page 29. Connect one pair of BNC cables between this port and the DS3 line.
2. Repeat step 1, using the next available pair of BNC PSTN interface ports.

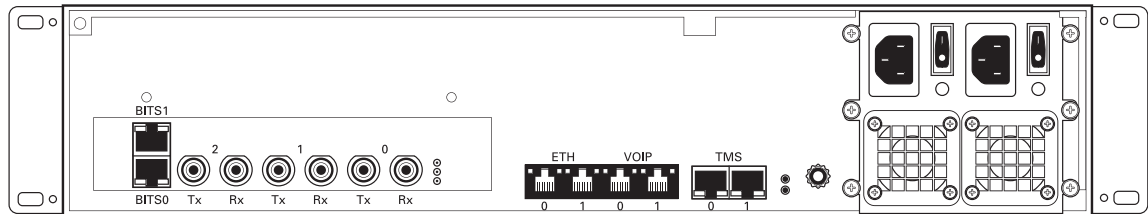


Figure 4.4

DS3 Interface to the PSTN

Note The (TMG7800-DS3 / TMG7800-STM1) features 2 Bits interfaces that can be used to synchronize the TDM network. It is recommended that you connect the Bits interface to the bits port of the TMG7800-TMS, if there is one installed in your system.

4.3.3 Optical Interface (OC3/STM-1) for the TMG7800-STM1

This section describes the connection to optical interfaces using two methods:

- Standard Connection (without an N+1 patch panel)
- N+1 Protection (with an N+1 patch panel)

Refer to table 4.1 on page 30 for a listing of optical interfaces. The default SFP module for OC3/STM1 connection is SMF, intermediate reach, (SFP-OC3-IR1) 1310 nm with LC type connectors.

Note Make certain that the correct SFP model is selected at the time of ordering. If your installation requires a different model from the one that has been provided, you must replace it.

Table 4.1 Optical Interfaces

Transceiver Model	Description	Spec	Mode	Type	Range (Km.)	Wavelength (NM)	Connection
SFP-OC3-IR1	OC3/STM1	Hot Pluggable	Single-mode	Intermediate reach	15	1310	LC
SFP-STM1E	STM1E (Electrical)	Hot Pluggable	75 ohms Cooper	Max 180m	1	NA	DIN (mini-coax)

A TMG7800-STM-1, with one main and one backup APS OC3 or STM1 port enables connection to OC3/STM1 lines. See figure 4.5 on page 31. The APS port is used for OC3/STM1 redundancy. Switchover occurs automatically based on configurable parameters. It is recommended that APS be used if the installation provides this feature.

Note Based on your requirements, follow either:

- Section 4.3.3.1 “Standard (Without an N+1 Patch Panel)” on page 31
- Section 4.3.3.2 “N+1 Protection (With an N+1 Patch Panel)” on page 31

Note The (TMG7800-DS3 / TMG7800-STM1) features 2 Bits interfaces that can be used to synchronize the TDM network. It is recommended that you connect the Bits interface to the bits port of the TMG7800-TMS, if there is one installed in your system.

4.3.3.1 Standard (Without an N+1 Patch Panel)

To connect the TMG7800-STM1 (Optical Interface) to the PSTN:

1. Connect a fiber optic cable between the Port 0 (Main) port and OC3/STM1 line, as shown in figure 4.5 on page 31.
2. Connect a fiber optic cable between the Port 1 (APS) port and OC3/STM1 line.

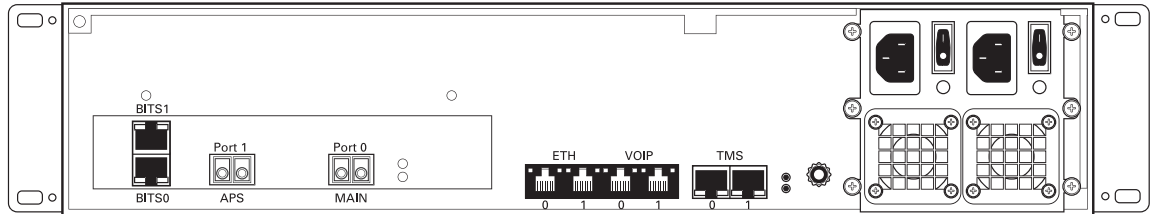


Figure 4.5 Optical Interface to the PSTN

4.3.3.2 N+1 Protection (With an N+1 Patch Panel)

To connect the TMG7800-STM1 (Optical Interface) to the PSTN:

1. Connect main fiber optic cables from each TMG7800-STM1 to a free port (0-14) on the Gateway side of a 7800 N+1 patch panel used for main connections. See figure 4.6 on page 31.
2. Connect APS fiber optic cables from each TMG7800-STM1 to a free matching port (0-14) on the Gateway side of a 7800 N+1 patch panel used for APS connections. See figure 4.6 on page 31.
3. If a TMG7800-STM1 is being used as the N+1 backup gateway, connect its main and APS fiber optic cables to the N+1 port on the Main and APS 7800 N+1 patch panels.

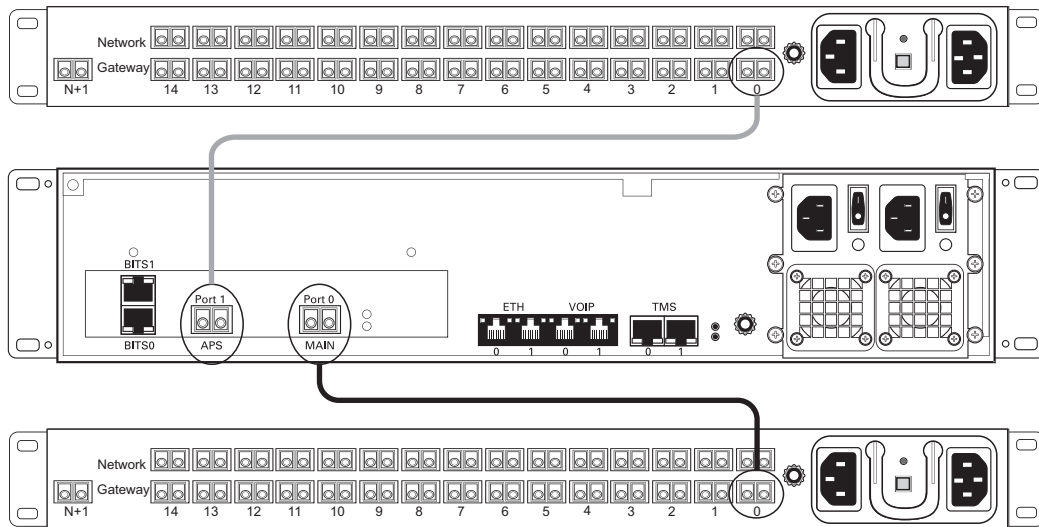


Figure 4.6 Optical Interface to the 7800 N+1 Patch Panel

Note To learn more about the connections to a 7800 N+1 patch panel, See “Connecting Fiber Optic Cables to the 7800 N+1 Patch Panel” on page 46 for more information.

4.4 Connecting to the TMS Network

Note Each connection from a 7800 Telecom Unit to the TMS network requires one CAT7 shielded Ethernet crossover cable with RJ45 type male-male connectors.

4.4.1 Connecting to the TMG7800 Telecom Units

The 7800-TMS enables you to scale your system by interfacing as many as sixteen 7800 Telecom Units with the 7800-TMS Switch network, building a non-blocking system of up to 32,768 channels. A second 7800-TMS provides your system with an active/standby high availability architecture.

4.4.1.1 Prerequisites

To interconnect the 7800 Telecom Units with the 7800-TMS, you will need:

- One CAT7 shielded Ethernet crossover cable with RJ45 type male-male terminations for each 7800 Telecom Unit connected to the 7800-TMS.
- If your system features a second 7800-TMS, you will require an additional CAT7 shielded Ethernet cable with RJ45 male-male terminations for each 7800 Telecom Unit.

4.4.1.2 Interconnections

See figure 4.9 on page 34 for an Ethernet crossover wiring diagram.

To interconnect the 7800-TMS:

1. Start with the 7800 Telecom Unit at the topmost position of the equipment rack and connect a CAT7 shielded Ethernet crossover cable to the TMS0 connector at the rear of the 7800 Telecom Unit, figure 4.7 on page 33. Connect the other end of the same CAT7 cable to the first port of the first 7800-TMS.

Note Ensure that the TMS0 port of each Telecom Unit connects to the same 7800-TMS switch.

2. If your system employs a second 7800-TMS, connect a second CAT7 shielded Ethernet crossover cable to TMS1 at the rear of the TMG7800 Telecom Unit, figure 4.7 on page 33. Connect the other end of the same CAT7 cable to the first port of a second 7800-TMS.

Note Ensure that the TMS1 port of each 7800 Telecom Unit connects to the same 7800-TMS switch.

3. Repeat steps 1-2 for each 7800 Telecom Unit until they have all been connected to the 7800-TMS.

Note All telecom units must use the same TMS port number when two 7800-TMS units are available.

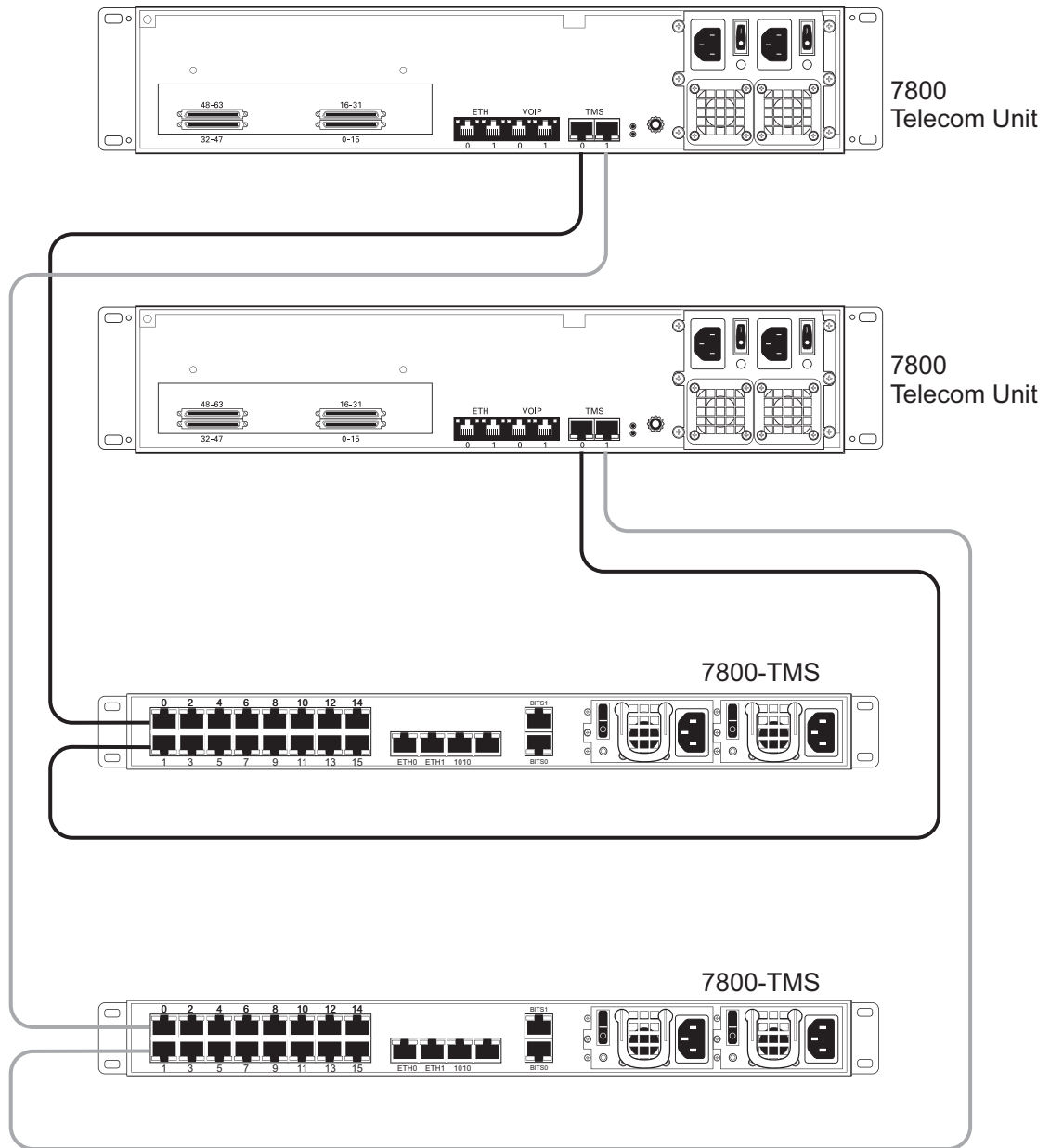


Figure 4.7 Interconnecting Two 7800 Telecom Units to an active and standby 7800-TMS

4.4.2 Interconnecting Two 7800 Telecom Units

If your 7800 Series gateway has no more that two 7800 Telecom Units, they can be connected to each other without the use of a 7800-TMS switch.

Simply connect the TMS0 ports of each unit together using a CAT7 shielded cross-over cable with RJ45 male-male terminations. Do the same for the TMS1 ports of each unit. See figure 4.8 on page 34.

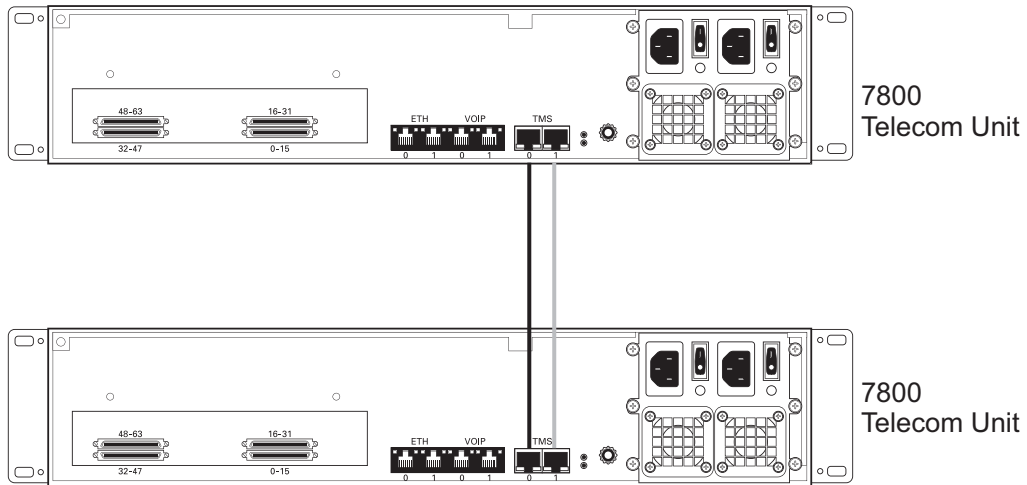


Figure 4.8 Interconnecting two 7800 Telecom Units.

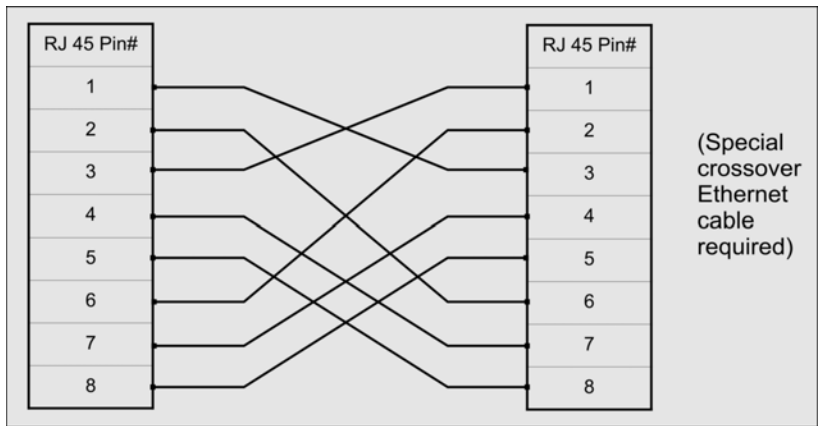


Figure 4.9 Ethernet Crossover Cable

4.5 Grounding the Equipment Chassis

As a standard safety practice, the chassis of the 7800 Telecom unit must be properly grounded to protect against any contact with an electrical fault condition. It is recommended that the chassis be connected to earth ground. When the 7800 Telecom unit is installed in an equipment rack, connect the ground wire between the ground lug of the Telecom unit and the equipment rack ground bar.

Guidelines

- Use 10 AWG (minimum) stranded ground wire.
- Terminate equipment side of ground wire with a #10 ring terminal.
- Keep the length of the ground wire as short as possible.
- Do NOT daisy chain the ground between equipment. Use a ground bus bar, as show in figure 4.10 on page 35.
- Do not over tighten ground lug connections.

To connect the 7800 Telecom unit to ground:

1. Connect one end of a ground wire to the ground lug of the 7800 Telecom unit. See figure 4.10 on page 35.
2. Connect the other end of the ground wire to a ground bar of the equipment rack. If the 7800 Telecom unit is not installed in an equipment rack, connect the ground wire to earth ground.
3. Verify that the resistance of the ground path is less than 0.5 ohms.

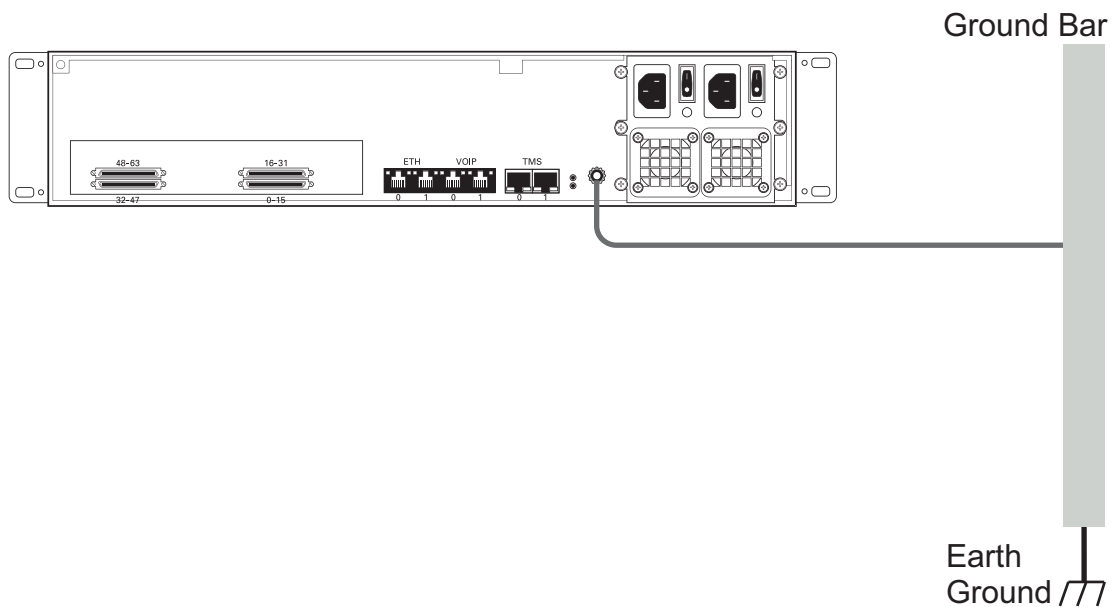


Figure 4.10 Chassis Ground Connection

4.6 Powering Up

The 7800 Telecom Units are furnished with two AC or DC power connections. Only once all other equipment installation work has been completed should the 7800 Telecom Unit be powered up.

4.6.1 Connecting to AC Power

Prerequisites

To power the 7800 Telecom Unit, you will need:

- One to two power sources.
- Two power cables.

The 7800 Telecom Unit AC model is furnished with two AC power connectors.

To connect the 7800 Telecom Unit to AC Power:

1. Connect an AC power cable between the AC connector of the 7800 Telecom Unit and an AC supply. See figure 4.11 on page 36.

Note If the 7800 Telecom Unit features a second power supply and it is not connected to an AC power source, press the green button located at the rear of the unit to disable the audible alarm. See figure 4.11 on page 36.

2. Power up the 7800 Telecom Unit by turning on its power switch(es).

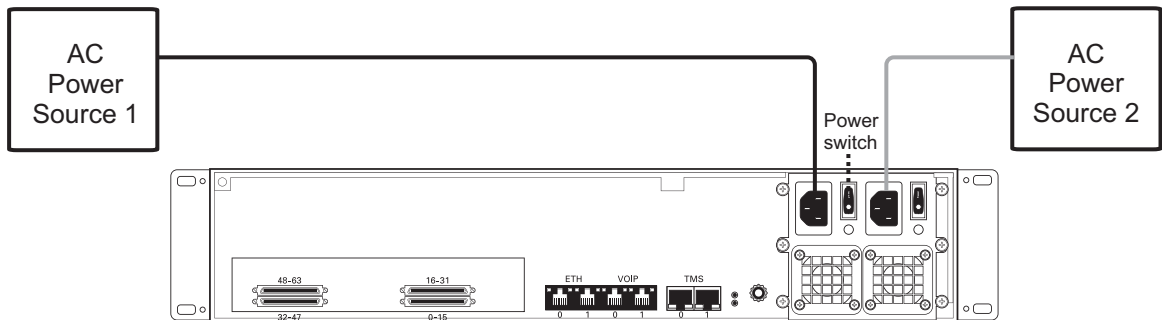


Figure 4.11 AC Power Connection

4.6.2 Connecting to DC Power

The 7800 Telecom Unit DC model is furnished with two DC power connection ports. In addition, each DC powered 7800 Telecom Unit is supplied with two DC power cables.

To connect the 7800 Telecom Unit to DC power:

1. Connect one DC cable, supplied with the 7800 Telecom Unit, as shown in figure 4.12 on page 37, to the DC outlet at the rear of the 7800 Telecom Unit.

Note Two types of cable with different coloring are available. Refer to figure 4.12 on page 37 for the appropriate wiring information.

2. Connect one lead of the DC power cable to the positive terminal of the DC power source.
3. Connect the other lead of the DC power cable to the negative side of the DC power source.
4. Repeat steps 1-3 for the second power DC power source.

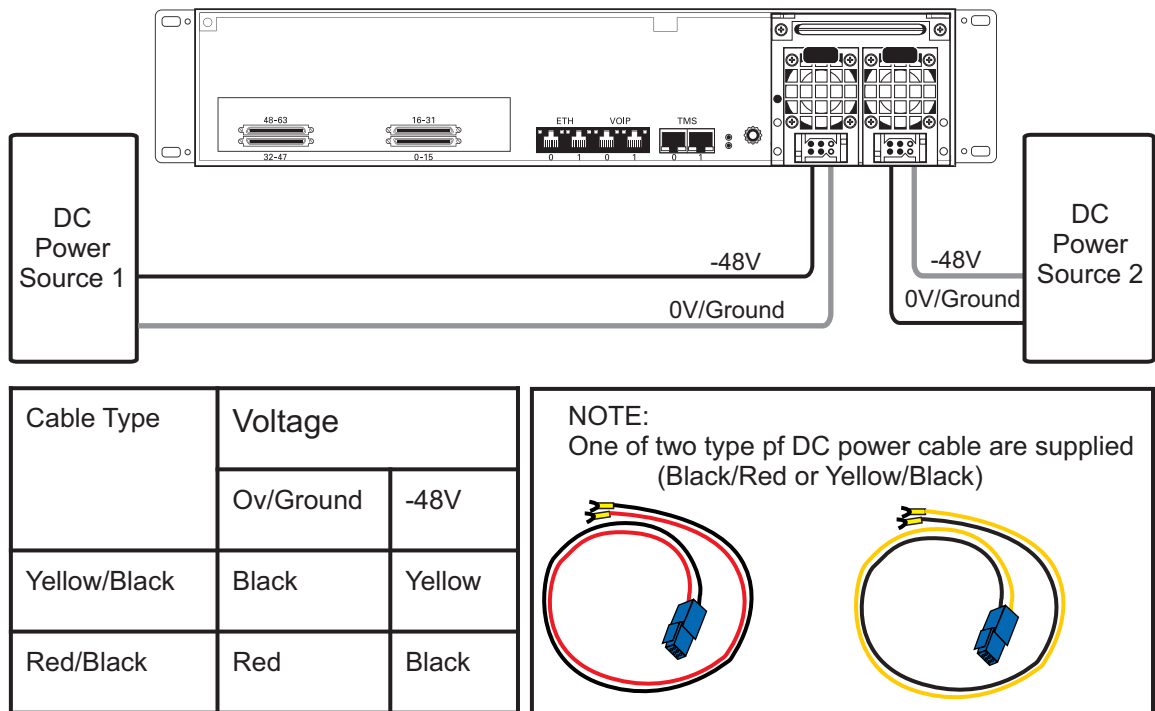


Figure 4.12 DC Power Connection

Section 5 Installing the 7800-TMS

This section covers the following procedures:

- Section 5.1 “Connecting to the Control Network” on page 39.
- Section 5.2 “Grounding the Equipment Chassis” on page 40.
- Section 5.3 “Powering Up” on page 42.

5.1 Connecting to the Control Network

The Control network enables the communication between the 7800-CTRL, the 7800 Series Telecom Unit(s), and the 7800-TMS.

Prerequisites

To connect the 7800-TMS, you will need:

- Two CAT5 Ethernet cables with RJ45 male-male terminations.

Connections

The 7800-TMS is connected to the 7800 series control network using two CAT5 Ethernet cables, as shown in figure 5.1 on page 39.

To connect to the control network:

1. Connect the ETH0 connector on the 7800-TMS to Control network switch one.
2. Connect the ETH1 connector on the 7800-TMS to Control network switch one.
3. Repeat step 1 and 2 for a second 7800-TMS.

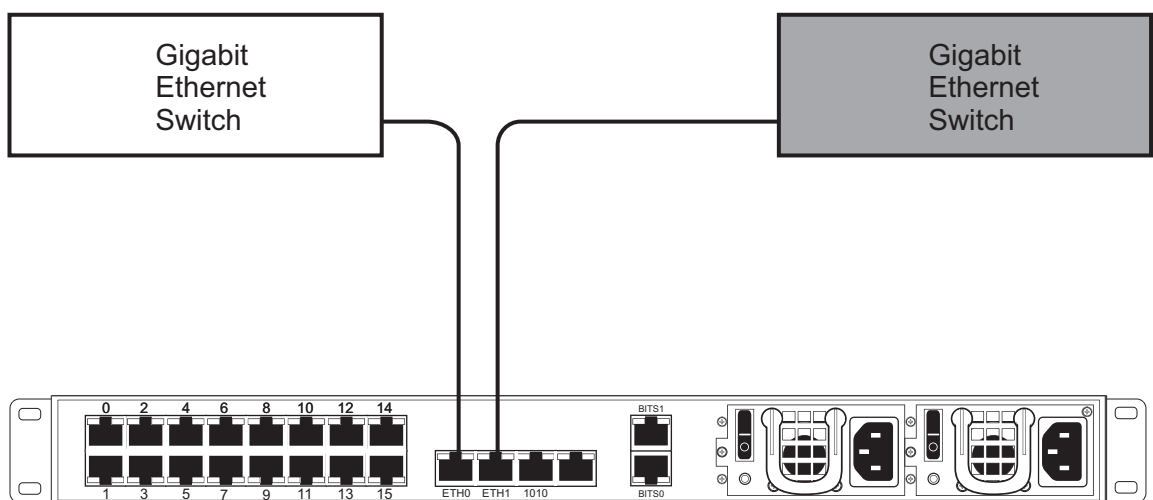


Figure 5.1 Connecting to the Control Network

5.2 Grounding the Equipment Chassis

As a standard safety practice, the chassis of the 7800 TMS must be properly grounded to protect against any contact with an electrical fault condition. It is recommended that the chassis be connected to earth ground. When the 7800 TMS is installed in an equipment rack, connect the ground wire between the ground lug of the unit and the equipment rack ground bar (figure 5.3 on page 41), or in the case of earlier 7800-TMS models (figure 5.2 on page 40), connect a ground wire between the power supply mounting bolt and the equipment rack ground bar.

Guidelines

- Use 10 AWG (minimum) stranded ground wire.
- Terminate equipment side of ground wire with a #10 ring terminal.
- Keep the length of the ground wire as short as possible.
- Do NOT daisy chain the ground between equipment. Use a ground bus bar, as show in Figure 5.2 on page 40.
- Do not over tighten ground lug connections.

5.2.1 7800 TMS (Earlier Models)

To connect an earlier model 7800 TMS unit to ground:

1. Connect one end of a ground wire to the power supply bolt of the 7800 TMS. See figure 5.2 on page 40.
2. Connect the other end of the ground wire to a ground bar of the equipment rack. If the 7800 TMS is not installed in an equipment rack, connect the ground wire to earth ground.
3. Verify that the resistance of the ground path is less than 0.5 ohms.

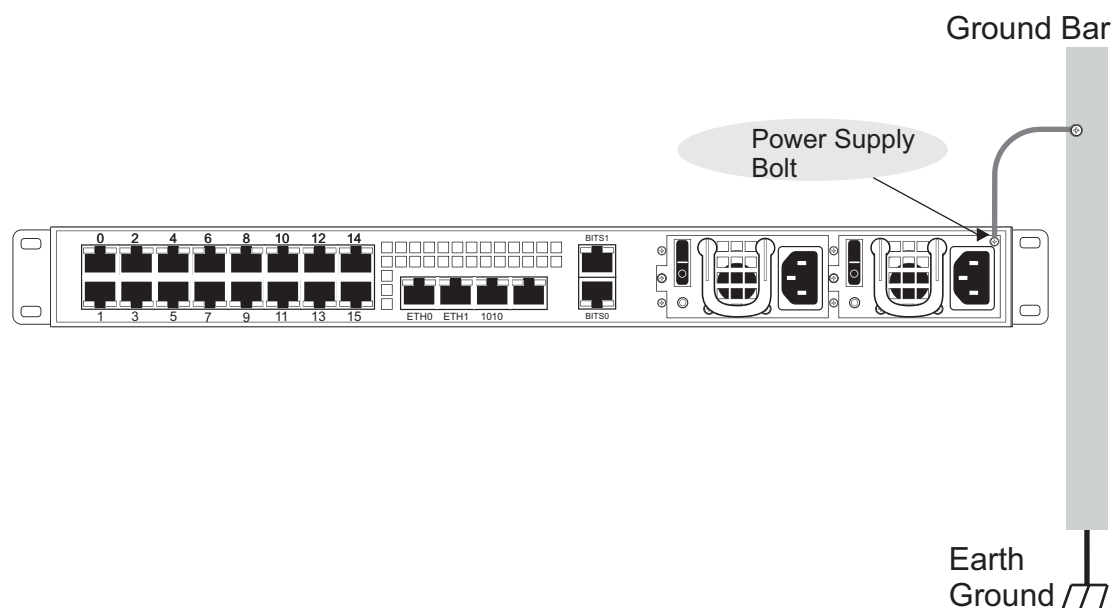


Figure 5.2 Chassis Ground Connection- 7800 TMS Earlier Models

5.2.2 7800 TMS (Later Models)

To connect a later model 7800 TMS unit to ground:

1. Connect one end of a ground wire to the chassis ground lug of the 7800 TMS. See figure 5.3 on page 41.
2. Connect the other end of the ground wire to a ground bar of the equipment rack. If the 7800 TMS is not installed in an equipment rack, connect the ground wire to earth ground.
3. Verify that the resistance of the ground path is less than 0.5 ohms.

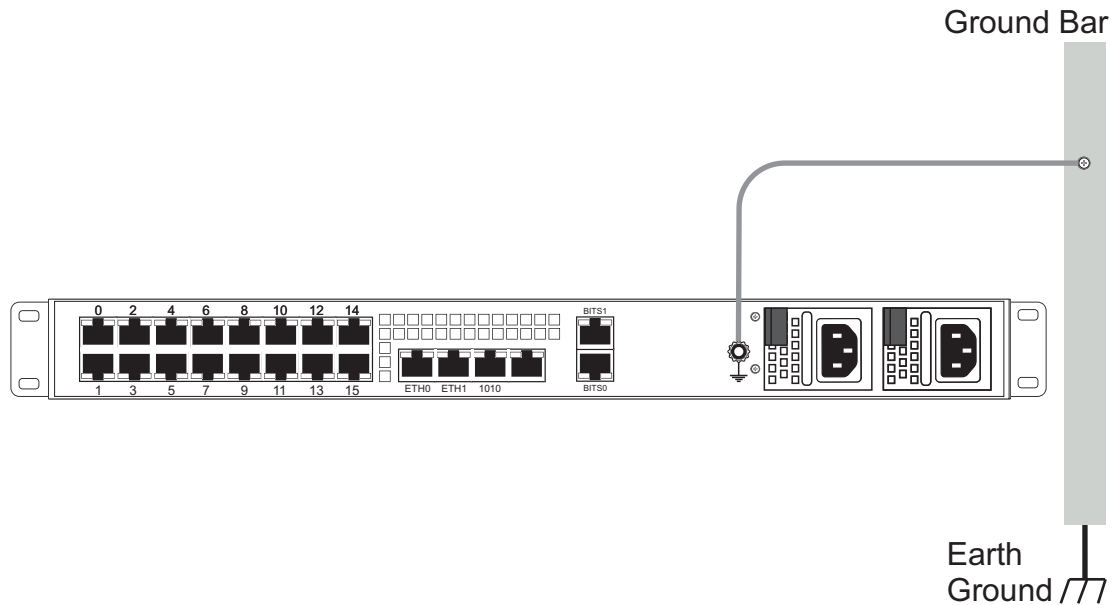


Figure 5.3 Chassis Ground Connection- 7800 TMS Later Models

5.3 Powering Up

The 7800-TMS is with two (2) AC or two (2) DC power connections. Only once all other equipment installation work has been completed should the 7800-TMS be powered up.

Prerequisites

To power the 7800-TMS, you will need:

- Two independent AC power sources.
- Two power cables for each 7800-TMS.

5.3.1 Connecting to AC Power

The 7800-TMS AC models are furnished with two AC power connectors.

To connect the 7800-TMS to AC Power:

1. Connect the first power connector of each unit to the first power source. See Figure 5.4.
2. Connect the second power connector of each unit to the second power source.

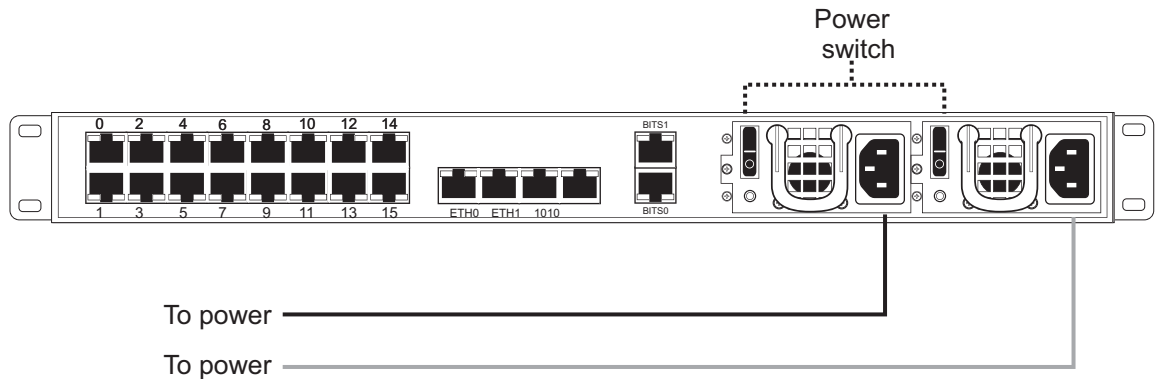


Figure 5.4 7800-TMS AC Power Connections

5.3.2 Connecting to DC Power

The 7800-TMS DC models are furnished with two DC power connection ports.

To connect the 7800-TMS to DC Power

1. Connect the first DC power connector of each 7800-TMS to DC power source one. See Figure 5.5 on page 43.
 - 1a. Connect one lead of each DC power cable to the positive terminal of the DC power source.
 - 1b. Connect the other lead of each DC power cable to the negative side of the DC power source.
2. Repeat the previous steps for DC power source two.

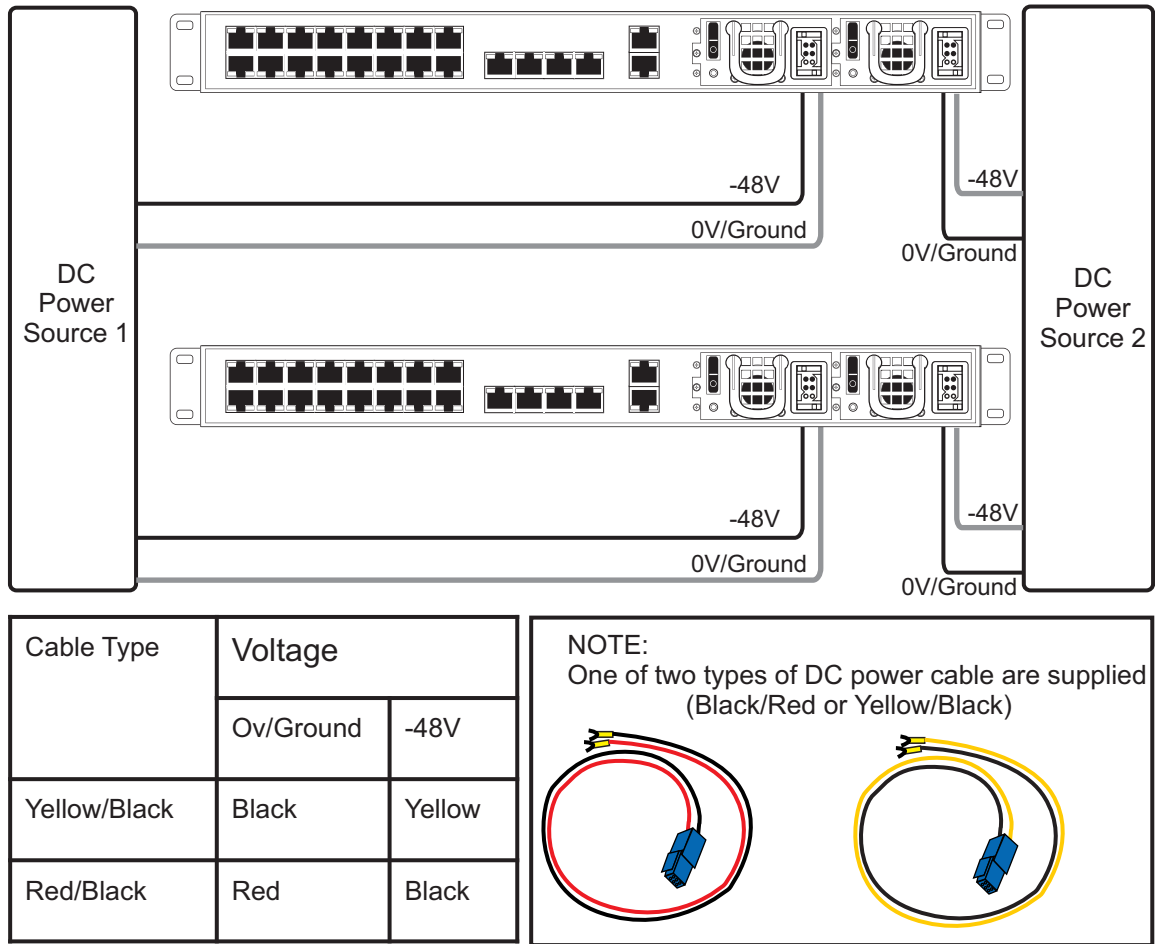


Figure 5.5 7800-TMS DC wiring diagram

5.4 TDM System Clock

The 7800 series system must be synchronized with the TDM network. This can be done in several ways:

- Synchronized with an incoming trunk
- Synchronized with a SONET SDH
- Synchronized with a BITS port

If your system features a 7800-TMS and a BITS interface is available, it is recommended that the BITS interface be connected to the BITS port of the 7800-TMS.

Section 6 Installing the 7800 N+1 Patch Panel

This section covers the following procedures:

- Section 6.1 “Connecting Fiber Optic Cables to the 7800 N+1 Patch Panel” on page 46.
- Section 6.2 “Connecting to the Control Network” on page 48
- Section 6.3 “Grounding the Equipment Chassis” on page 49
- Section 6.4 “Connecting to AC Power” on page 50.

6.1 Connecting Fiber Optic Cables to the 7800 N+1 Patch Panel

The 7800 N+1 patch panels function as the bridge between the provider network and the TMG7800-STM1 gateways. To properly wire your gateways to the 7800 N+1 patch panel(s) to provide N+1 protection, follow these guidelines.

1. Prepare a diagram that links each Tmedia unit serial number with an N+1 patch panel port and the network provider's STM1. This diagram will help for the web portal configuration later on.
2. Relate the fiber optic cables from the network provider with each TMG7800-STM1 and use the same port number that is assigned to each TMG7800-STM1. See Figure 6.1 on page 47
3. If Automatic Protection Switching (APS) is used then repeat the EXACT SAME numbering scheme for each APS connection. For example, if a TMG7800-STM1 is assigned port number one on a 7800 N+1 patch panel that is being used for main connections, then the APS connections must also be assigned port number one on a 7800 N+1 patch panel that is being used for APS connections.
4. Connect the TMG7800+1 unit to the N+1 port of the N+1 patch panel.

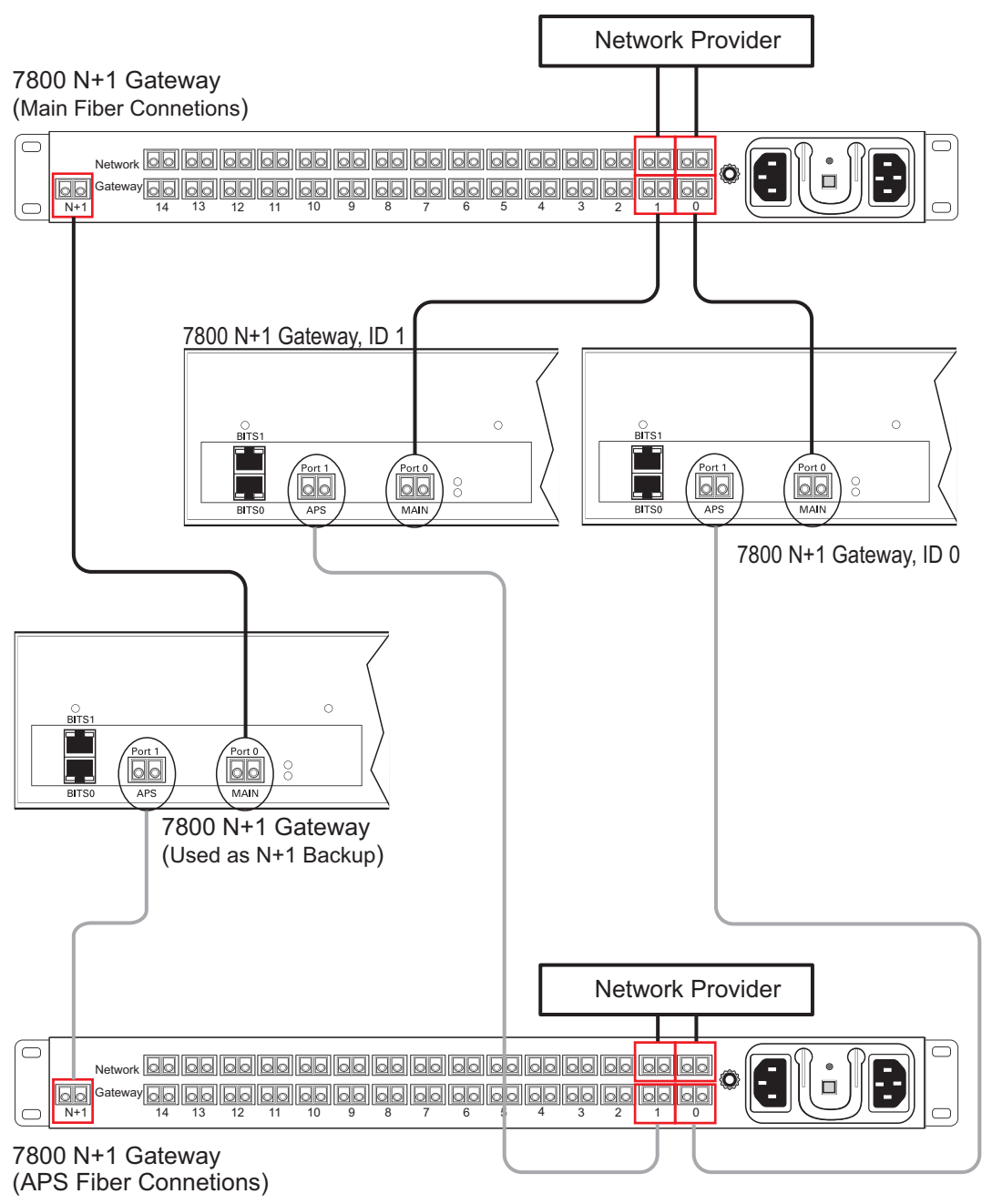


Figure 6.1 Optical Interface Connections to the 7800 N+1 Patch Panel

6.2 Connecting to the Control Network

The 7800 Series Control network enables communication between the 7800-CTRL, the 7800 Telecom unit(s), the 7800-TMS, and 7800 N+1 patch panel(s).

Prerequisites

To connect the 7800 N+1 patch panel(s) to the control network, you will need:

- Two CAT5 Ethernet cables with RJ45 male-male terminations for each 7800 N+1 patch panel.

Connections

The 7800 N+1 patch panel(s) are connected to the control network using two CAT5 Ethernet cables, as shown in Figure 6.2 on page 48.

To connect to the control network:

1. Connect the ETH0 connector on the 7800 N+1 patch panel to the control network switch one.
2. Connect the ETH1 connector on the 7800 N+1 patch panel to the control network switch two.
3. Repeat steps 1 and 2 for an additional 7800 N+1 patch panel.

7800 N+1 Patch Panel

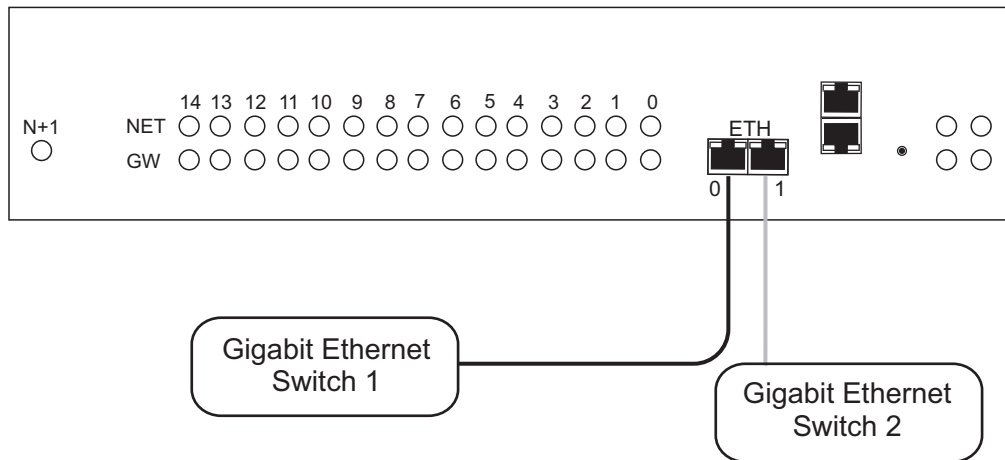


Figure 6.2 Connecting to the Control Network

6.3 Grounding the Equipment Chassis

As a standard safety practice, the chassis of 7800 N+1 patch panel must be properly grounded to protect against any contact with an electrical fault condition. It is recommended that the chassis be connected to earth ground. When the 7800 N+1 patch panel is installed in an equipment rack, connect the ground wire between the ground lug of the patch panel and the equipment rack ground bar.

Guidelines

- Use 10 AWG (minimum) stranded ground wire.
- Terminate equipment side of ground wire with a #10 ring terminal.
- Keep the length of the ground wire as short as possible.
- Do NOT daisy chain the ground between equipment. Use a ground bus bar.
- Do not over tighten ground lug connections.

To connect to the 7800 N+1 Patch Panel to ground:

1. Connect one end of a ground wire to the ground lug of the 7800 N+1 Patch Panel. See Figure 6.3 on page 49.
2. Connect the other end of the ground wire to a ground bar of the equipment rack. If the 7800 N+1 Patch Panel is not installed in an equipment rack, connect the ground wire to earth ground.
3. Verify that the resistance of the ground path is less than 0.5 ohms.

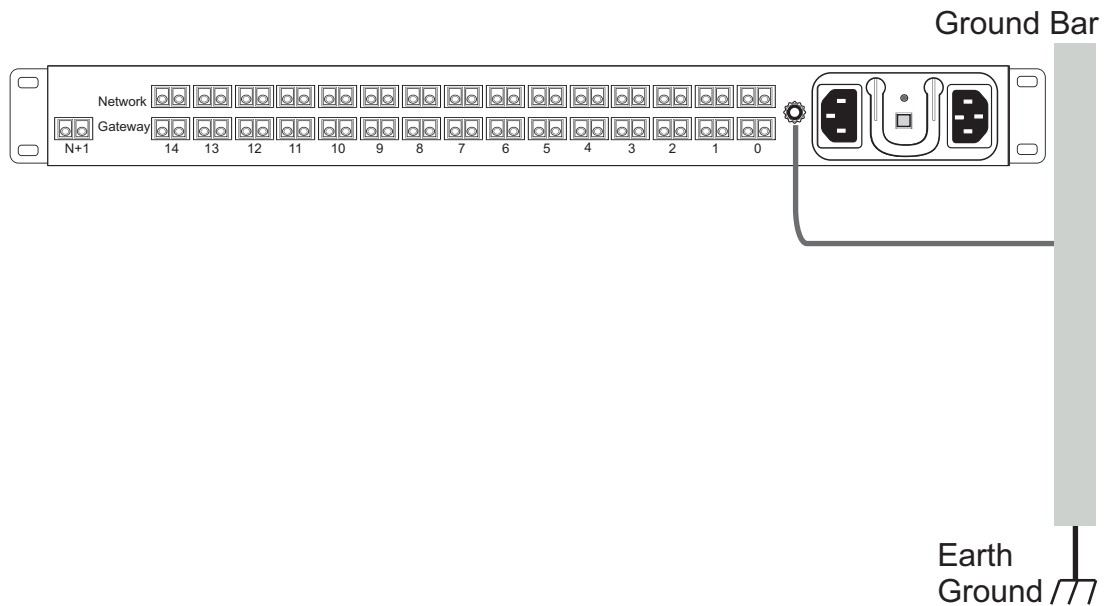


Figure 6.3 Chassis Ground Connection

6.4 Connecting to AC Power

The 7800 N+1 patch panel is furnished with two AC power connections. Only once all other equipment installation work has been completed should the equipment be powered up.

Prerequisites

To power the 7800 N+1 patch panel, you will need:

- One to two power sources.
- Two power cables.

To connect the 7800 N+1 Patch Panel to AC Power:

1. Connect an AC power cable between the AC connector of the 7800 N+1 Patch Panel and an AC supply. See Figure 6.4 on page 50.
2. Power up the 7800 N+1 patch panel by turning on its power switch.

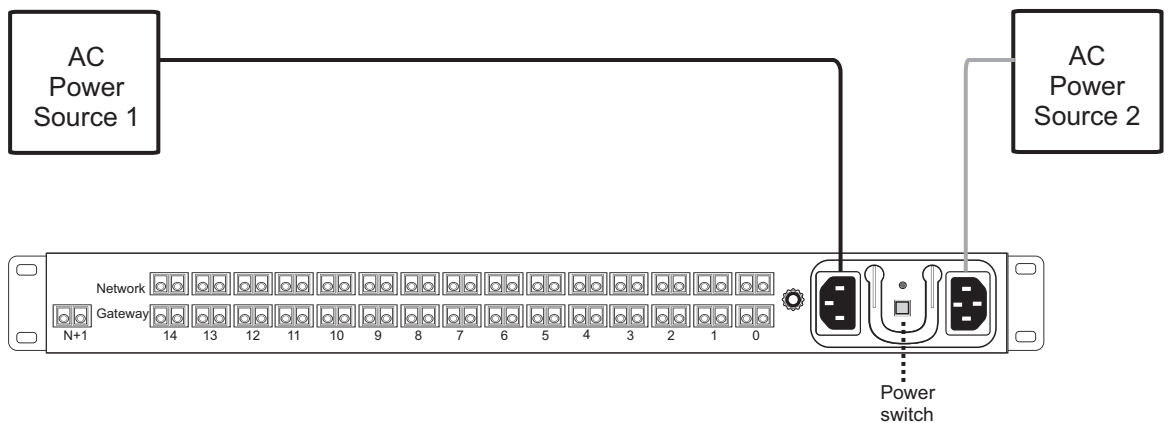


Figure 6.4 AC Power Connection

Section 7 Start Up and Verification

This section provides information about the following topics:

- Section 7.1 “Start Up”
- Section 7.2 “Verifying the LED Status Indications”

Note To learn about the IP address for your system or how to change it, refer to Section 9.5 “Changing the 7800 Series Gateway Management Port IP Address” on page 62.

7.1 Start Up

1. Connect to the web portal of the 7800 series gateway. The Welcome page appears.



2. Follow the web portal instructions to configure your unit as a secondary unit in a new 7800 series system.
3. Before clicking the “yes, it is connected like that already” button, make sure that the physical connections have been properly done.

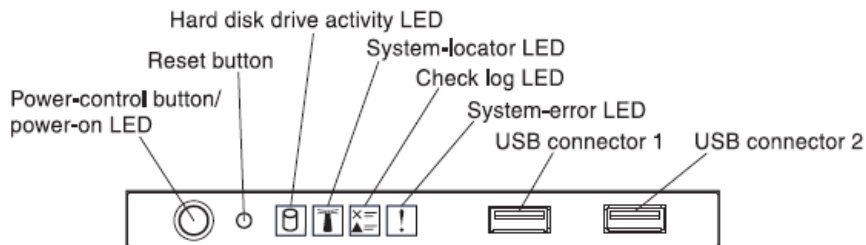
7.2 Verifying the LED Status Indications

When the 7800 series gateway has been powered up, verify the LEDs of each unit to determine that all indications are normal.

7.2.1 7800-CTRL

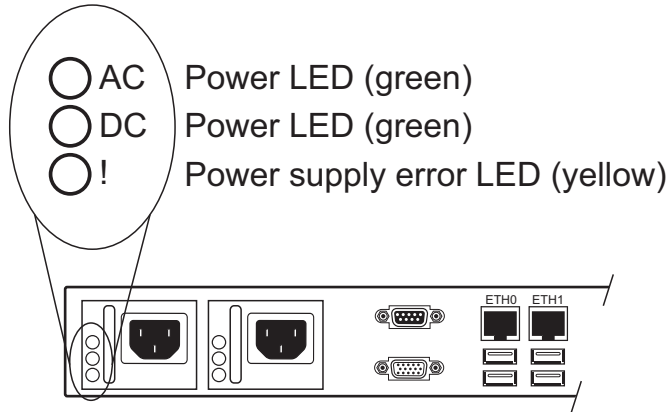
To determine the operating health of the 7800-CTRL, verify the LED statuses of at the front and the rear of the unit.

7.2.1.1 Operator Information Panel-Front of Unit



LED/Button	Description
Power-control button and power-on LED	Press this button to turn the server on and off manually. The states of the power-on LED are as follows: <ul style="list-style-type: none"> – Off: Power is not present or the power supply, or the LED itself has failed. – Flashing rapidly (4 times per second): The server is turned off and is not ready to be turned on. The power-control button is disabled. This will last approximately 5 to 10 seconds. – Flashing slowly (once per second): The server is turned off and is ready to be turned on. You can press the power-control button to turn on the server. – Lit: The server is turned on.
Reset button	Press this button to reset the server and run the power-on self-test. You may need to use a pen or the end of a straightened paper clip to press the button.
Hard disk drive activity LED	When this LED is flashing, it indicates that the associated hard disk drive is in use.
System locator LED	Use this blue LED to visually locate the server among other servers. This LED is also used as a presence detection button. You can use IBM Systems Director to light this LED remotely. This LED is controlled by the IMM2.
Check Log LED	When this yellow LED is lit, it indicates that a system error has occurred. Check the event log for additional information.
System error LED	When this yellow LED is lit, it indicates that a system error has occurred. Check LEDs on the system board to help isolate the error or identify the failed part. This LED is controlled by the IMM2.

7.2.1.2 Power Supply-Rear of Unit



Power Supply LED Indicators					
AC	DC	Error	Description	Action	Notes
On	On	Off	Normal Operation		
Off	Off	Off	No AC power to the server, or there is a problem with the AC power source.	<ul style="list-style-type: none"> - Verify the AC power to the server. - Make sure that the power cord is connected to a functioning power source. - Restart the server. If the error remains, check the power-supply LEDs. - If the problem remains, replace the power-supply. 	This is a normal condition when no ac power is present.
On	Off	Off	Faulty system board or faulty power supply	<ul style="list-style-type: none"> - Turn off the server and disconnect the power cord from the server; then, reconnect the power cord. - If the system board error (fault) LED is not lit, replace the power supply. - (Trained technician only) If the system board error LED is lit, replace the system board. 	
On	Off or flashing	On	Faulty power supply	Replace the power supply.	
On	On	On	Power supply is faulty but still operational	Replace the power supply.	

7.2.2 7800 Telecom Unit

Once the 7800 Telecom Unit has run successfully through its system boot procedures, the following will be displayed in an alternating fashion as described in Table 7.1 on page 54:

Table 7.1 7800 Telecom Unit Displays

Display Order	Display
First Screen	IP 0: <ip address of eth0. E.g. 192.168.0.2> IP 1: <ip address of eth1 E.g. 192.168.0.3>
Second Screen	<board type. eg. TMP-STM1, TMS-16, TMP-DS3, TMP-16, TMP-32, TMP-64> <adapter name e.g. TB002821> <serial number e.g. TB002821> <release used e.g V2.2.0 RC1>

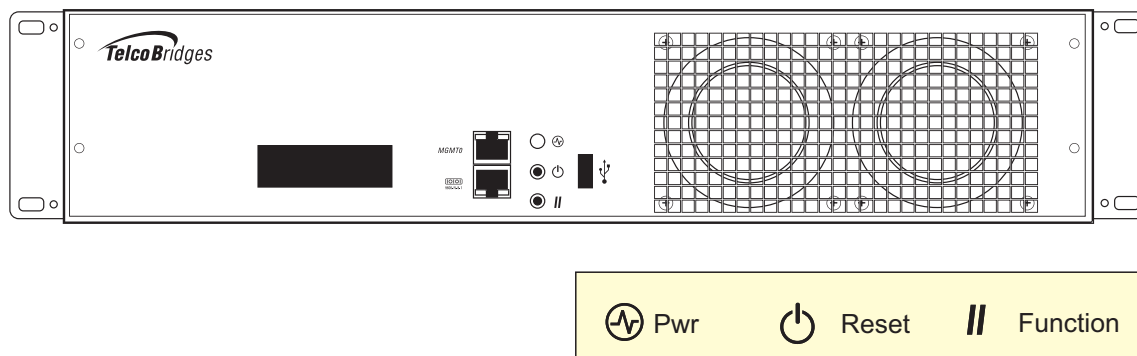


Figure 7.1 Front display and LEDs

If the reset button is pressed a software menu will appear on the display at the front of the unit. Press the function button to select one of the two actions listed in Table 7.2 on page 54. Once your selection is made, press the reset button to acknowledge your choice.

Table 7.2 Reset Menu Options

Menu Choices	Description
M Options:	
e >Shutdown	Graceful shutdown of the 7800 Series gateway. This takes a few minutes. Press the reset button to restart the Tmedia VoIP gateway.
n Rst telecom	Reboots the telecom platform of the 7800 Series gateway.

7.2.3 7800-TMS

Once the 7800-TMS has run successfully through its system boot procedures, the following will be displayed in an alternating fashion as described in Table 7.1 on page 54:

Table 7.3 7800-TMS Displays

Display Order	Display
First Screen	Toolpack controlled from host <serial number>
Second Screen	Serial <Serial number> IP <eth0 ip>/<eth1 ip>

When pressing the reset button, the following will appear (it is only possible to restart, no shutdown option available):

```
Reset?
>Yes
  No
```

Select with the function button, then press the reset button again to apply the change.

7.2.4 7800 N+1 Patch Panel

Once the 7800 N+1 Patch Panel has run successfully through its system boot procedures, the following will be displayed as described in Table 7.4 on page 56:

Table 7.4 7800 N+1 Patch Panel LEDs Description

LED	Display
Net	<ul style="list-style-type: none"> • Solid Green: Laser received from network. • Black: Not configured. • Red: Configured but no laser is received.
GW	<ul style="list-style-type: none"> • Black: Configured normal state, or not configured. • Blinking yellow: Unit replaced by backup unit. • Blinking red: Replaced but no signal is received from the network.
N+1	<ul style="list-style-type: none"> • Black: N+1 unit is in standby. • Blinking green: N+1 unit is active. • Blinking red: Replaced but no signal is received from the network.
4 LEDs to the far right	<ul style="list-style-type: none"> • Top left: Green (power on); Red (booting) • Bottom left: Green steady (ready); yellow or green blinking (booting); red (boot sequence error) • Top right: Unused • Bottom right: Black (patch panel OK); red (hardware failure)

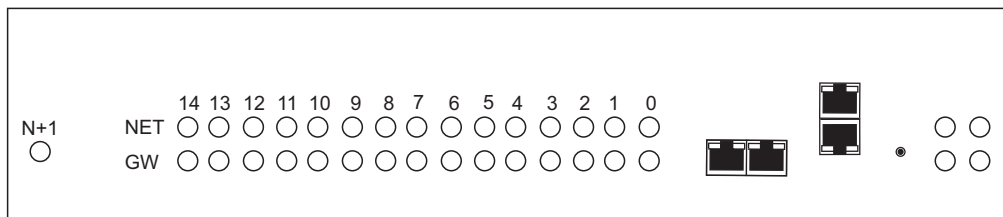


Figure 7.2 7800 N+1 Patch Panel LEDs

Section 8 Powering Down the Equipment

This section provides the following power-down topics:

- Section 8.1 “7800-CTRL”
- Section 8.2 “7800 Telecom Unit”
- Section 8.3 “7800-TMS”

8.1 7800-CTRL

Powering down the 7800 Series gateway requires that the Linux embedded host be shut down. In order to do this, you must connect to the management interface using SSH, and enter:

```
shutdown -hP now
```

Attention DO NOT TURN OFF the power to the 7800 Series gateway using the power switch located at the rear, unless the Linux host has been properly shut down beforehand, instead use the reset button display, or manually use the shutdown command.

Allow enough time for the Linux host to shut down before turning off the power to the 7800 Series gateway (ex. 1 minute). Be aware that the shutdown procedure of the unit is logged and traceable for support and warranty purposes.

8.2 7800 Telecom Unit

Unplug the power cord from the unit. The unit can be restarted using restart button on the front of the unit.

Note As an alternate method to this procedure, refer to Section 7.2.2 “7800 Telecom Unit” on page 54, to power down the Tmedia VoIP gateway with the reset button.

8.3 7800-TMS

Unplug the power cord from the unit. The unit can be restarted using restart button on the front of the unit.

Note As an alternate method to this procedure, refer to Section 7.2.2 “7800 Telecom Unit” on page 54, to power down the Tmedia VoIP gateway with the reset button.

8.4 7800 N+1 Patch Panel

Unplug the power cord.

Section 9 Initial System Configuration

This section provides information about the following topics:

- Section 9.1 “Connecting to the 7800-CTRL Console”
- Section 9.2 “Configuring the Terminal Emulator Application”
- Section 9.3 “Connecting to the 7800 Series Gateway”
- Section 9.4 “Retrieving 7800 Series Gateway Information”
- Section 9.5 “Changing the 7800 Series Gateway Management Port IP Address”
- Section 9.5 “Changing the 7800 Series Gateway Management Port IP Address”
- Section 9.7 “Setting the Time Zone”
- Section 9.8 “Configuring the 7800 Series Gateway Using the Web Portal”
- Section 9.9 “Changing VoIP Interface Addresses”

9.1 Connecting to the 7800-CTRL Console

Note The default IP addresses for the management ports are located in the “Important Notice” sheet received with the shipment. MGMT ports are configured in bonding.

If you do not know the default IP address, go to Section 9.5 “Changing the 7800 Series Gateway Management Port IP Address” on page 62.

The serial port interface enables administrators to perform management tasks on the 7800 Series gateway. You can connect to the serial port of a 7800-CTRL, using one of the following three methods.

Method 1: Null modem DB9 female-female cable

1. Connect a null modem DB9 female-female cable between the DB9 serial port of your computer and the DB9 serial port of the 7800-CTRL. See Figure 9.1 on page 60.

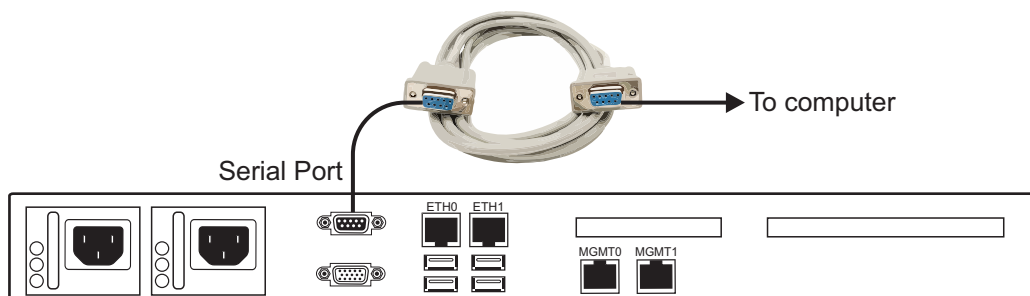


Figure 9.1 7800-CTRL Serial Port Connection

Method 2: USB to DB9 adapter

1. Connect the USB connector of the cable to a USB port on your computer and the DB9 male connector of the cable to one end of a null modem DB9 female-female cable. Connect the other end of the null modem DB9 female-female cable to the DB9 serial port of the 7800-CTRL. See Figure 9.2 on page 60.

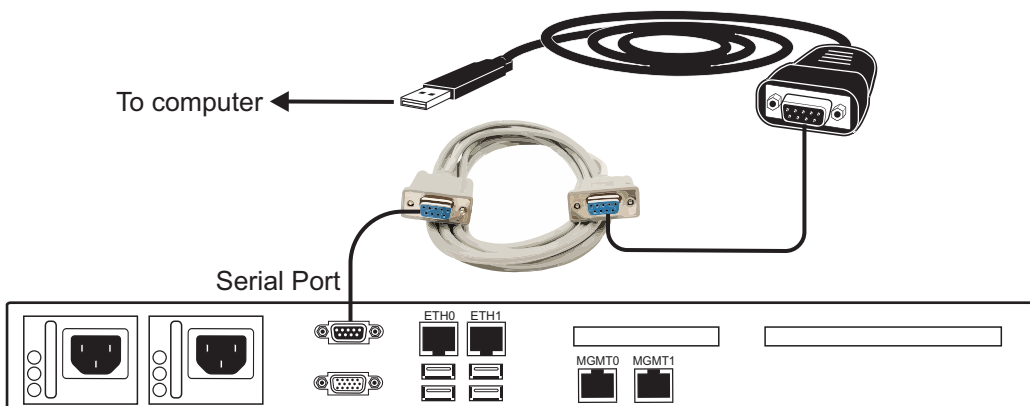


Figure 9.2 USB to DB9 Adapter

Method 3: VGA Monitor, USB Keyboard, and USB Mouse

1. Connect a VGA monitor to the VGA port of the 7800-CTRL. Connect a USB keyboard to an available USB port on the 7800-CTRL. Do the same for a USB mouse See Figure 9.3 on page 61.

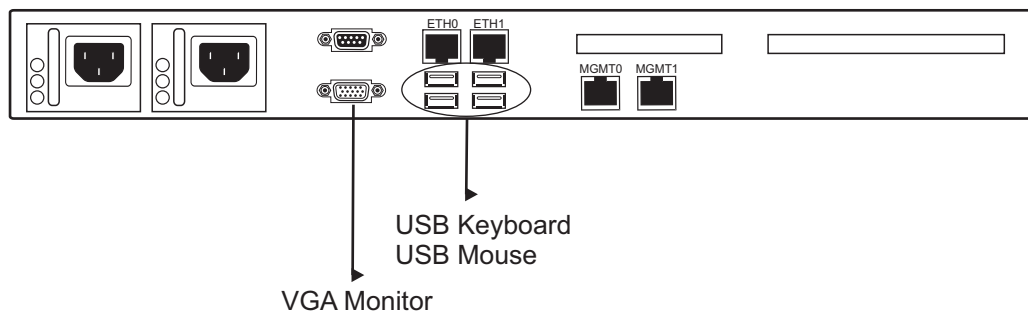


Figure 9.3 USB to DB9 Adapter

9.2 Configuring the Terminal Emulator Application

Before initiating communication with the management interface, you must first configure a terminal emulator or console application to communicate with the 7800 series system in order to configure initial settings. Available terminal emulation software includes:

- HyperTerminal
- Putty
- Minicom

To configure the terminal emulator application:

1. Set the baud rate (bits per second) to **9600**
2. Set the data rate to **8 bits**
3. Set the parity to **None**
4. Set the stop bits to **1**
5. Set the flow control to **None**

Note See Section 9.5 on page 62 to learn how to change the IP address of the MGMT0 port.

9.3 Connecting to the 7800 Series Gateway

The 7800 Series Gateway is shipped with the TMG-CTRL preinstalled. In order to make changes to the system configuration, you must connect the port labelled MGMT0 at the front of the 7800 Series Gateway to a terminal.

To access the 7800 Series Gateway, you must use an SSH connection. The password is set at the factory and is indicated on the shipment sheet.

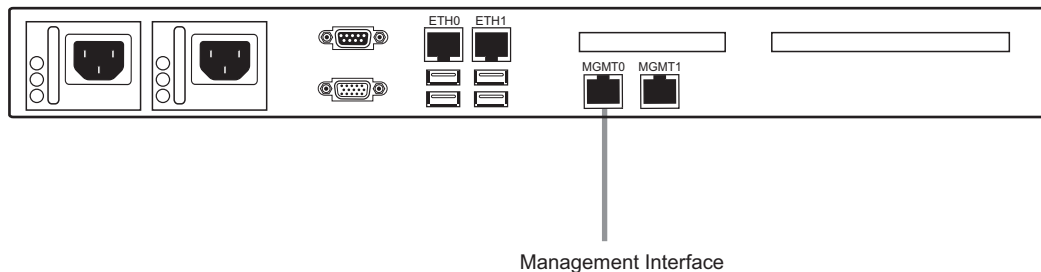


Figure 9.4 7800 Series Management Interface

9.4 Retrieving 7800 Series Gateway Information

The 7800 series gateway enables you to retrieve system information with the following shell commands:

- `tbproduct` (retrieve the 7800 series gateway product type). See http://docs.telcobridges.com/mediawiki/index.php/TMG:Get_Product_Type, for further information.
- `tbserial` (retrieve the 7800 series gateway serial number). See http://docs.telcobridges.com/mediawiki/index.php/TMG:Get_Serial_Number, for further information.

9.5 Changing the 7800 Series Gateway Management Port IP Address

The management port of the 7800 series gateway (MGMT0 and MGMT1) are configured in bonding by default and the values are located on the “Important Notice” sheet.

The values can be modified using the following shell script:

```
tbchangeip
```

Note If you do not have the “Important Notice” sheet, the default IP address and netmask are set as follows:

MGMT0

- IP address: 172.24.0.2
- Netmask: 255.255.255.0

MGMT1

- IP address: 172.24.0.3

- Netmask: 255.255.255.0
-

9.6 Changing 7800 Series Gateway Management Port Passwords

Once logged you are logged on to the Tmedia VoIP Gateway, type “passwd”, to change the password being used. The following information will be displayed:

```
[root@TB003540 ~]# passwd

Changing password for user root.
New UNIX password:
Retype new UNIX password:
passwd: all authentication tokens updated successfully.
```

9.7 Setting the Time Zone

You can change the time zone of the 7800 series gateway using the *tbtimezone* shell command.

9.8 Configuring the 7800 Series Gateway Using the Web Portal

Note: The first time that you connect to the web portal, you will need to configure the role of the 7800-CTRL. See Section 7.1 “Start Up” on page 51

To change the default configuration of a 7800 series gateway using the Web Portal, follow the steps described in the Web Portal System Configuration Tutorial Guide, found on the TBWiki:

<http://docs.telcobridges.com>

The Web Portal can be accessed with a Web browser.

The default url is: `http://[7800-ctrl MGMT0 IP address]:12358`

Note If your system features two 7800-CTRL units, they can access the Web Portal from either one of their IP addresses.

The default login information to access the Web Portal application is:

- Username: root
- Password: root

9.9 Changing VoIP Interface Addresses

The default address of the VoIP interfaces of the 7800 series gateway can be modified. To learn how this is done, refer to the Web Portal tutorial guide on the Telcobridges TB Wiki at docs.telcobridges.com.

Section 10 System Backups

This section provides information about the following topics:

- Section 10.1 “Creating a Database Backup”
- Section 10.2 “Downloading a Database Backup”
- Section 10.3 “Uploading a Database Backup”
- Section 10.4 “Restoring a Database Backup”

For more detailed information with regard to any of the points described in this section, please refer to the TBWiki: <http://docs.telcobridges.com>

10.1 Creating a Database Backup

It is important that backups be made of system configuration settings in the event of a system failure. It is recommended that a backup be made once the system has been configured. Backups are performed using the web portal.

10.2 Downloading a Database Backup

A backup of system data is stored on the hard drive of the 7800 series gateway. It is important that system backups be downloaded to an external storage device.

10.3 Uploading a Database Backup

An external backup of your database can be uploaded to your 7800 series gateway.

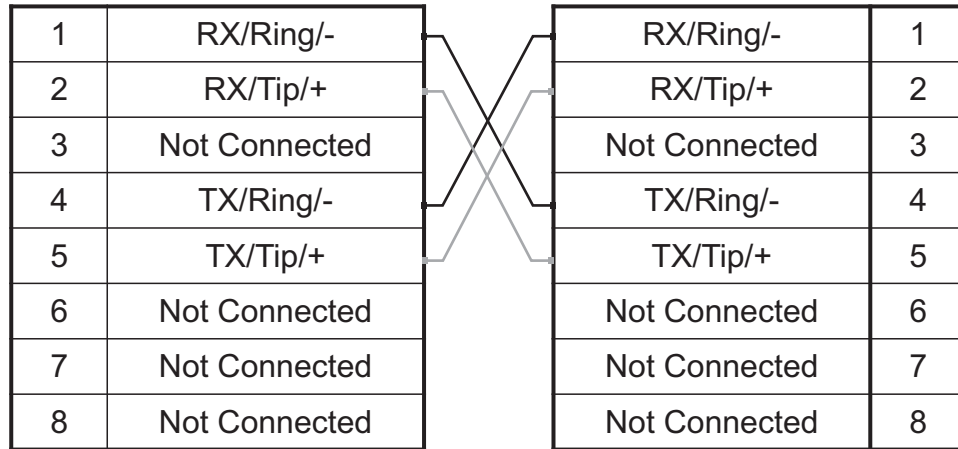
10.4 Restoring a Database Backup

In the event of a system failure requiring the replacement of a 7800 series gateway, a previously saved backup of system settings can be restored to the new unit.

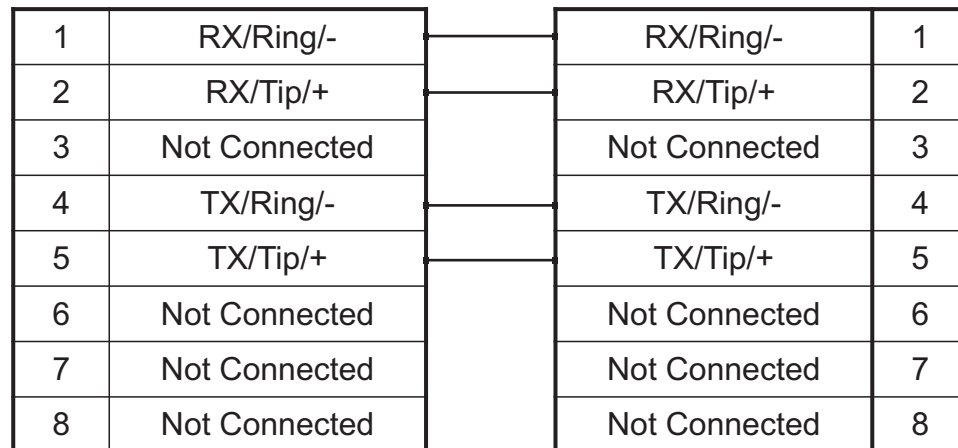
Appendix A Wiring Diagrams

A.1 RJ48C Wiring Diagram: Crossover and Straight Cables

RJ 48 (T1/E1/J1) Wiring Schematic: Crossover Cable



RJ 48 (T1/E1/J1) Wiring Schematic: Straight Cable



A.2 RJ48 Console Wiring Diagram

